

2

1

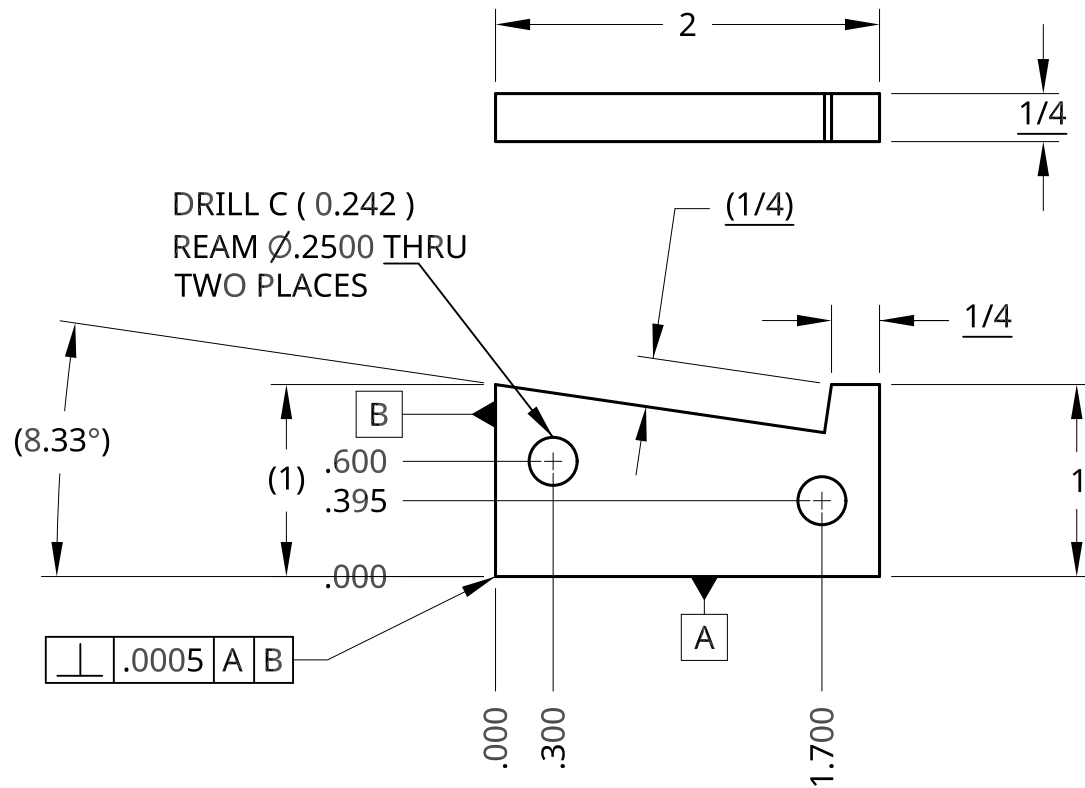

METHOD:
SQUARE BLANK TO SIZE.
DRILL AND REAM HOLES.
PUT PINS THROUGH HOLES AND
SUPPORT ON MILL VISE WITH PINS.
MILL ANGLED SURFACE.

ONLY THE HOLE LOCATIONS AND THE
PERPENDICULARITY OF A AND B MATTER.
ALL OTHER DIMENSIONS ARE AS DESIRED.

IT IS PROBABLY BEST TO MAKE
A MATCHED PAIR TOGETHER.

CREDIT TO JOE PIECZYNSKI
FOR THIS METHOD

	NAME	DATE	<i>CircuitousRoot</i>	
DRAWN	DAVID M.	03/16/2020	TITLE BARTH TYPE CASTER MATRIX SHOE TOOLING ANGLE BLOCK	
CHECKED			SIZE A	
APPROVED			DWG NO. ANGLEBLOCK8P33	
DO NOT SCALE DRAWING			REV. 2	
BREAK ALL SHARP EDGES AND REMOVE BURRS	MATERIAL	FINISH	SCALE 1:1	
THIRD ANGLE PROJECTION	AS APPROPRIATE		WEIGHT	
			SHEET 1 of 1	

2

1