

## XI. The Various Models

**E**SSENTIALLY there are but two distinct models of the Linotype—the single distributor and the plural distributor, each designed for specific requirements of the printing art.

The original Linotype, the Model 1, was a single distributor machine, having a magazine of comparatively limited capacity with reference to the size of faces that could be used. It was designed primarily for straight newspaper body matter.

Immediately following the successful introduction of the Linotype to the newspaper composing room, the book publishers demanded improvements which would adapt it to the composition of larger faces and wider *measures for book work*. These improvements involved magazines of larger capacity and with certain mechanical features to facilitate rapid and easy change of face, body and measure, as represented in the Model 3 and Model 5. In order to anticipate further requirements of both newspaper and book printers and to keep pace with the rapid development of the art as a whole, other improvements in the design of the Linotype took the form of a *plurality of magazines* and molds as an integral unit of the machine. Thus we have the Model 8 and Model 14. These various steps in the evolution of the Linotype have preserved the basic principle of the single distributor mechanism. These developments have brought the single distributor Linotype up from a machine of limited capacity for straight newspaper composition, setting one face and one body size, to the present multiple-magazine model which will produce a dozen different faces, measures and bodies ranging up to 30 and 36 ems 60 point, all at the tips of the operator's fingers.

The other model or type of Linotype, the plural distributor, was developed for the job printer and the ad room, whose requirements demanded more rapid change of faces than is possible with the single distributor, and at the same time the *possibility of assembling four or more* different styles of faces in one line continuously without any delay in the distribution of matrices to the various magazines on the machine. The development of this type of machine began with an equipment of two magazines. This was followed with improvements which were designed to increase its range and utility in conformity with the normal development and growth of the printing industry. Today the *plural distributor multiple-magazine Linotype* is a self-contained composing room, capable of producing display advertising, job and book work, decorative and spacing material, and in fact perform

every requirement of the modern composing room with speed and economy and in the highest degree of quality.

A more detailed description of these two models of Linotype follows:

#### MODEL 8

*Quick-change three-magazine Linotype.* In its general features the Model 8 Linotype resembles the Model 5, but it is greatly in advance of that model, in that it carries three magazines, any one of which can be quickly brought into operation. The upper two magazines can be quickly removed from the machine at the front and replaced by others. The third magazine can be removed, but this requires a little more time. All magazines of the Models 5, 8, 14, 25 and 26 are interchangeable with magazines of the Model 8.

The Model 8 Linotype has but one distributor, and therefore matrices from different magazines cannot be mixed in the same line. An automatic device prevents the magazines from being shifted until all matrices have left the distributor bar. This obviates all danger of matrices being returned to the wrong magazine.

*Shifting Magazines.*—The three magazines rest on frames, the lowest of which is supported by an elevating screw in a barrel. A handle at the front of the machine is connected with the elevating screw by a universal joint. By turning this handle the magazines can be raised or lowered to bring any one of the three into register with the front. Connected with this handle is a mechanism which locks and unlocks the sliding bars which locate the magazines in proper position. On later machines these bars are locked and unlocked by separate handle in front of the machine. In either case, when the handle is released the locking bars slide into place automatically and lock the magazines in position.

To shift from one position to another the handle is given a quarter turn to the right, which lifts the weight of the magazine frame from the locating bars, then a quick forward thrust unseats the locating bars, and permits the magazine frame to be lowered or elevated by a turn of the handle. If the forward thrust does not at first unseat the locating bars, the handle has not been set at the correct position, and the bars are binding in the seat on the magazine frame, or all the matrices have not left the distributor bar, or one is caught at the front.

In elevating the magazines from the first to the third position, continue to press inward on the handle while turning, otherwise locating bars will not permit the magazine frame to pass the second position without automatically locking.

#### MODEL 8—REMOVING MAGAZINES

*Removing the Middle Magazine.*—Insert the locking bar in the top and second magazines. Raise the magazines with the elevating mechanism, as high as they will go. Place the frame supports under the upper magazine

frame. Remove the bar which extends across the top side of the top magazine. Turn the elevating crank until the frame descends and the second magazine is in operating position, leaving the upper magazine elevated. Place the right- and left-hand cams on the second magazine frame. Lift out the escapements of the upper magazine. Then proceed as in removing the upper magazine.

*Removing the Lower Magazine.*—Remove the two upper magazines and take off the frame cams; take out the sight screws that hold the right- and left-hand gibs to the frame guides; remove the gibs, using care not to get them mixed. Remove the two frames from the guides; take out the two clamps that hold the lower magazine at the rear. Have a helper stand on the frame of the machine in the rear, and reach over the top of the distributor beam to assist in lifting the magazine, while the operator in front gradually raises the magazine clear of the escapement frame.

*Releasing a matrix on the Model 8.*—The following action takes place:

The keyboard cam lifts the keyboard reed, which acts upon the escapement lever, in turn operating the horizontal slide and escapement. The escapement levers, when not in action, stand just clear of the mouth of the magazines, and do not interfere with the raising or lowering of them. Care should be taken to see that these levers work freely in their guides, and occasionally they should be cleaned with a little gasoline, and a *little* oil applied by the finger on the working points.

The distributor channel entrance is in all essentials like the distributing channel entrance of the Model 5. The pivoting point, however, is different, being so arranged that in case a matrix protrudes from the back end of the magazine the entrance will open as the magazine is lowered.

*Recently a change has been made in the supporting frames for the magazines on the Model 8 and by turning a handle all three of the magazines can be readily removed and replaced.*

#### MODEL 9—FOUR-MAGAZINE LINO TYPE

The four-magazine Model 9 Linotype is radical in many of its features, and was designed to meet varied requirements for advertising, head-letter, and job composition calling for frequent change of face and body.

It is equipped with four interchangeable, superimposed magazines, and the matrices from any one of the four magazines can be instantly brought into operation by the shifting of a lever, and they are all controlled from the one standard Linotype keyboard, thus placing eight different faces at the operator's command without leaving his seat. Besides this, any additional characters of infrequent use may be set into the matrix line instantly by hand, and, after casting, these will return automatically to the pi box.

Any face may be set continuously, or all faces may be mixed in the same line, enabling one operator to set complete display advertising, involving many different styles and sizes of faces on different bodies and to

varying measures, far more rapidly, economically and effectively than could ever be done in any other way.

As all of the magazines are interchangeable and may be quickly removed and replaced by others, a range of style and faces may be carried sufficient to make the Model 9 Linotype a self-contained jobbing office or ad composing department.

By equipping the four magazines with suitable matrices, the newspaper office may set at a continuous operation large news heads, sub heads, in condensed faces body matter, display figures and advertisements. The job office with suitable equipment may set chapter heads, sub heads, marginal notes, foot notes and body matter in roman, italic, small heads, sub heads, marginal notes, foot notes and body matter in roman, italic, small capitals and black faces of different styles and sizes.

The water-cooled mold disk carries four molds which give a large range of bodies and measures without necessitating a change of liners, while the universal ejector and universal knife block are instantly adjustable for all bodies and measures.

The magazines themselves remain stationary when in place, and the shift from one magazine to another is done with a lever and is simple, easy and instantaneous. Each magazine is provided with a series of escapements controlling the delivery of its matrices. The escapements of all four magazines are actuated by a single series of escapement rods, mounted in a frame. Each escapement rod has four notches in its edge, and as the shifting lever is moved it raises or lowers the escapement rods so that their upper ends connect with the escapement verges of the magazine required, and at the same time the escapement levers engage with the proper notch in the edge of the escapement rods, thus connecting the escapement with the keyboard mechanism.

By swinging the front of the machine open, the escapement rods and mechanism become easily accessible.

After casting, the line of matrices is lifted in the usual manner by the second elevator for distribution. From the second elevator the matrices pass through a primary distributor box on to a short primary distributor bar where they are separated according to font for the different magazines. This bar is provided with groups of teeth separated by blank spaces so that as each matrix advances along the bar it will be engaged by the successive groups of teeth, but will be released from the bar during its travel across the intervening spaces. Beneath the path of the matrices, as they travel along the primary bar, are stationary bridges, one being located beneath each of the blank spaces on the bar. These bridges have projections to correspond to the notches in the lower end of the matrices. As the matrix advances it will ride on the bridge while crossing a blank space and engage the teeth of primary bar at the next succeeding point, thus advancing alternately by riding a bridge or being suspended on the teeth

of the bar, until the projections on the teeth exactly correspond to the notches in the matrix, when it drops below the teeth of the bar and, after passing over the bridge, falls into a tube which carries it to a lower distributor box and thence on to the distributor bar and to its proper channel in the magazine.

#### MODEL 14

This is substantially a Model 8 three-magazine Linotype, with the addition of an auxiliary magazine of twenty-eight channels located to the right of the main magazine.

The auxiliary magazine is operated by a special keyboard placed at the right of the main keyboard. This magazine will carry a cap alphabet of head-letter matrices or two sets of advertising figures, small job fonts, or twenty-eight of any kind of special matrices that may be desired, in addition to the standard fonts on the three main magazines. Matrices from any one of the regular magazines can be mixed in the line with those from the auxiliary magazine.

The auxiliary magazines are short, carrying nine matrices in each channel. They are small and light and may be readily removed and replaced by others carrying different faces as desired. A bracket has been attached to the rear of the machine which will hold three extra auxiliary magazines to further facilitate the use of the auxiliary magazines. There are two auxiliary keyboards, one overlying the other, the upper one so hinged that it may instantly be swung downward and backward out of the way. The buttons on the upper keyboard, when in operative position, are in contact with those of the lower keyboard and, through them, operate the escapement mechanism.

The main magazines are interchangeable with those of Models 5, 8, 25 and 26.

#### SINGLE KEYBOARD MODEL 14

This new Model is called Single Keyboard Model 14. In this machine the auxiliary magazine is operated from the main keyboard instead of having a separate keyboard as formerly used. Fig. 130 is a diagrammatic view of the operation of the auxiliary magazine from the regular keyboard. *A* is the ordinary key lever, *B* the regular key weight or key bar, *C* the ordinary trigger, *D* the ordinary cam yoke, and *E* the reed which works the escapements through the supplementary levers *K*. The key reed *E* has a lug or projection upon it, *F*. The regular position of this key reed *E* is shown in the dotted lines. When in this position the operation of the keyboard reed, supplementary lever and escapement is exactly the same as in the ordinary Model 8.

When it is desired to operate the auxiliary keyboard, the reeds *E* are moved toward the rear of the machine a little by means of a shift key located at the left of the keyboard adjacent to the spaceband key. When

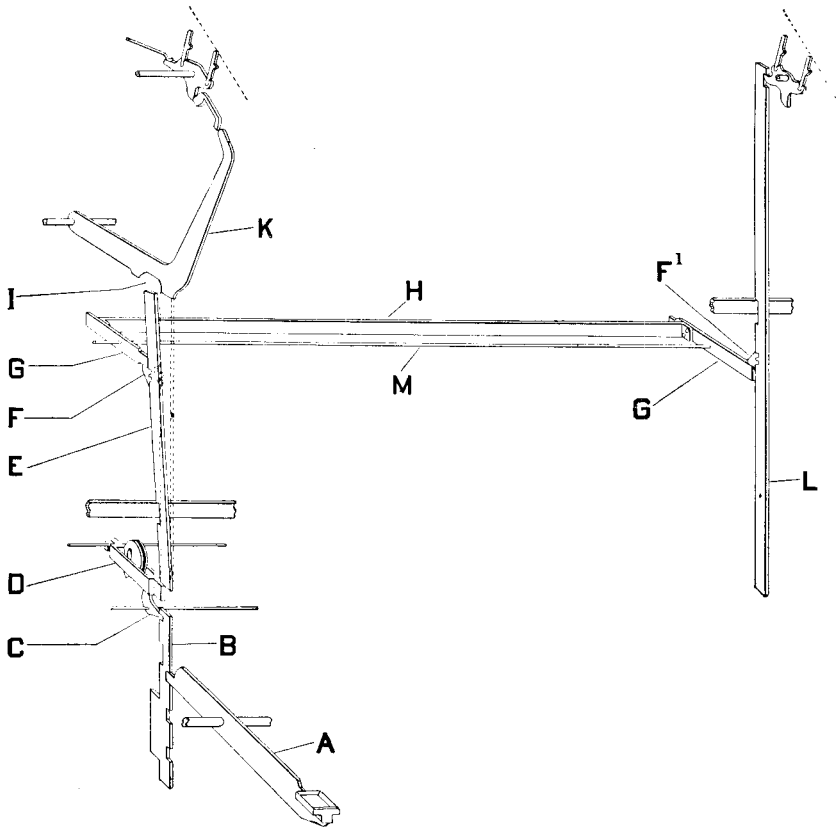

FIG. 130.—Action of Escapement for the Model 14 Single Keyboard Linotype.

in this position the lug *F* registers with the lever *G* which is mounted on a rod *M*, and this lever is connected on its rear side by a piece *H*, which runs to the auxiliary side of the machine. This device, consisting of the levers *G* and the connecting bar *H*, form a frame adapted to revolve around the rod *M*. This revolving frame is called a bail. It is evident that when the reed *E* rises under the action of the cam yoke *D* it will revolve the bail, causing the lever *F*<sup>1</sup> to raise the reed *L* operating the ordinary escapement for the auxiliary magazine. In this way the matrices are discharged from the auxiliary magazine. At this time the reed *E* does not operate the subsidiary lever *K*, as there is a notch *I* made in the lever into which the reed passes at the time the auxiliary magazine is being operated.

When the operator wishes to obtain matrices from the regular or main magazines, a touch on the shift key brings the reed *E* back into position to operate the subsidiary lever *K* in the regular manner. At this time the lug *F*<sup>1</sup> does not engage the lever *G*, shown in Fig. 130.

The operation of this shift key is very quick and easy, and corresponds identically in its action to the shift key for caps on a typewriter.

The bails are mounted in a metal box, which is designed so that it can be readily removed from and replaced on the machine.

The auxiliary magazines on the Single Keyboard Model 14 are somewhat wider than the ordinary auxiliary magazines on the Model 14, and will take up to 24 point, full width, and condensed characters up to 60 point. There are thirty-four characters in the auxiliary magazine, giving a full cap and figure font for use in ads, etc.

In other respects than those mentioned, the machine is similar to the Model 14 which has been in use for many years. The new Single Keyboard Model 14 has proved to be very popular and has found a large market.

#### MODEL 21

The Model 21 Linotype is also a display machine and resembles the Model 20 Linotype with the difference that it has a special keyboard, on the right-hand side of which there is a lever, and as this lever is pulled forward it locks 17 of the keylevers on the keyboard, and at the same time it shifts the connection between the keylevers and the keybars, so that many of the remaining keys on the keyboard, which are operative, release the matrices from entirely different channels of the magazine. When this mechanism is used the matrices run in only 55 channels of the magazine and therefore much larger matrices setwise can be used, and with this arrangement, extended faces up to 36-point can be used. In addition to the regular channel entrance for the 72-channel magazine, the Model 21 is equipped with a special channel entrance of 55 channels to accommodate those matrices too large to run regularly. One channel entrance may be swung out of position and the other swung into place almost instantly and without any adjustment. The Model 21 magazines are exactly the same as those used on the Model 20 and are interchangeable with the magazines of the Models 20 and 22.

#### MODEL 22

The Model 22 display machine is the same in every respect as the Model 21 display Linotype, except that it carries an auxiliary magazine of 28 channels in addition to the regular magazine. This auxiliary magazine, located at the right of the regular magazine, is controlled by an independent keyboard directly beneath it and within easy reach of the operator. The auxiliary magazine and keyboard are exactly the same as those on the Model 14.

#### SINGLE KEYBOARD MODEL 22

This model is a modification of the original Model 22, the auxiliary magazine being worked from the main keyboard in precisely the same general manner as in the Single Keyboard Model 14. The arrangement of

the shift key, bails, auxiliary reeds and escapements is exactly the same except in dimensions as in the Model 14. This gives the advantage of the single-keyboard action in this model.

#### MODEL 24

The Model 24 Linotype is equipped with four regular Model 9 magazines and two auxiliary magazines of 65 channels each, capable of holding six full fonts of matrices from the smallest 5-point up to extended 36-point, and being a multiple-distributing Linotype it is possible to set matrices from all six magazines in the same line, and permits continuous composition from and distribution to all magazines. The Model 24 is substantially a Model 9 with two full-size auxiliary magazines on the right-hand side, controlled by an independent keyboard directly beneath it and within easy reach of the operator. Touching one or the other of two shift keys (marked upper and lower) on the left-hand side of the auxiliary keyboard, instantly brings into operation either the upper or the lower auxiliary magazine.

The auxiliary magazines are half length and unusually wide, and the two sections are fastened together so that in removing them from or replacing them on the machine they are a complete unit. The auxiliary magazines are special and cannot be used in any other model of machine. Both the regular and auxiliary magazines are removed from the front of the machine in the same manner as the Model 9. Matrices for the regular magazines of Models 9 and 24 are separated by a combination of three notches in the lower end of the matrix and a bridge with corresponding projections in the primary distributor. Matrices for the auxiliary magazines are separated by a combination of No. 1 and No. 9 notches in the matrix and corresponding projections, or absence of them, on the bridges, and are cut away in the center so as to pass over the bridges which control the regular magazine matrices.

#### MODEL 25

This is a two-magazine machine, the magazines being of the regular Model 5 or 8 type, and interchangeable with these models. There is a double distributor similar to that used in the Model 16. A distinguishing feature of this machine is the fact that the support for the magazines at the rear of the machine is directly under the distributor and as close to it as possible. The magazines are mounted on these pivot points so that the front of the magazines can swing up and down about two and one half inches, bringing either one of the magazines into register with the ordinary Model 8 front.

The channel entrances on this machine are made slightly wider from front to rear, and as the pivot point upon which the magazines swing is so close to the distributor, the channel entrances swing only a very slight distance.



This enables the distributor to discharge its matrices into the channel entrances continuously regardless of the swinging up or down of the front ends of the magazines.

When the operator desires to change magazines from the upper to the lower, or vice versa, the front ends of the magazines are swung up and down by a lever within easy reach of the right hand of the operator.

The weight of the magazines is balanced by a strong spring mounted in a frame on the distributor bracket. In this way the swinging movement of the magazines is very easy and can be quickly done by using the lever.

The great advantage of this machine is the fact, first, that it is a mixing machine and that matrices from both magazines may be mixed in one line; second, the assemblage and the distribution are continuous so that the operator does not lose time waiting for matrices to distribute or in raising and lowering the magazines as in the case of a single-distributor machine like the Model 8.

#### MODEL 26

The Model 26 is in every respect similar to the Model 25 except that it has two auxiliary magazines, each containing thirty-four characters. These magazines are pivoted near their upper end in the same manner as the main magazines in the Model 25 and the front end of these auxiliary magazines can be swung up and down so as to bring either of these magazines into register with the front. This swinging of the auxiliary magazines is done by a handle in exactly the same manner as the main magazines. They are counterbalanced by a spring in a similar manner to that described in the Model 25. These magazines register with the double distributor at their upper end and the distributor is similar to that used in the Model 25 except that it is longer.

The operation of the auxiliary magazine is the same as that described in the Single Keyboard Model 14 except that there is a subsidiary reed similar to the reed *K* shown in Fig. 130, which operates the escapements of their magazine. The bail box, bails, and in general, the mechanism for operating the auxiliary magazines is the same as that used in the Single Keyboard Model 14.

In the Model 26 there are the same advantages as in the Model 25 of continuous assemblage and distribution, of mixing matrices from both magazines in the same line with the additional advantage that there are two auxiliary magazines which permit the use of two display cap fonts and their figures, or of special characters of any description.

#### NEW LOWER DISTRIBUTOR BOX

In the Model 25 and 26 Linotypes there is a primary distributor. The matrices are delivered to this primary distributor and then by means of notches in the foot of the matrix they are sent to either of the two lower distributor boxes.

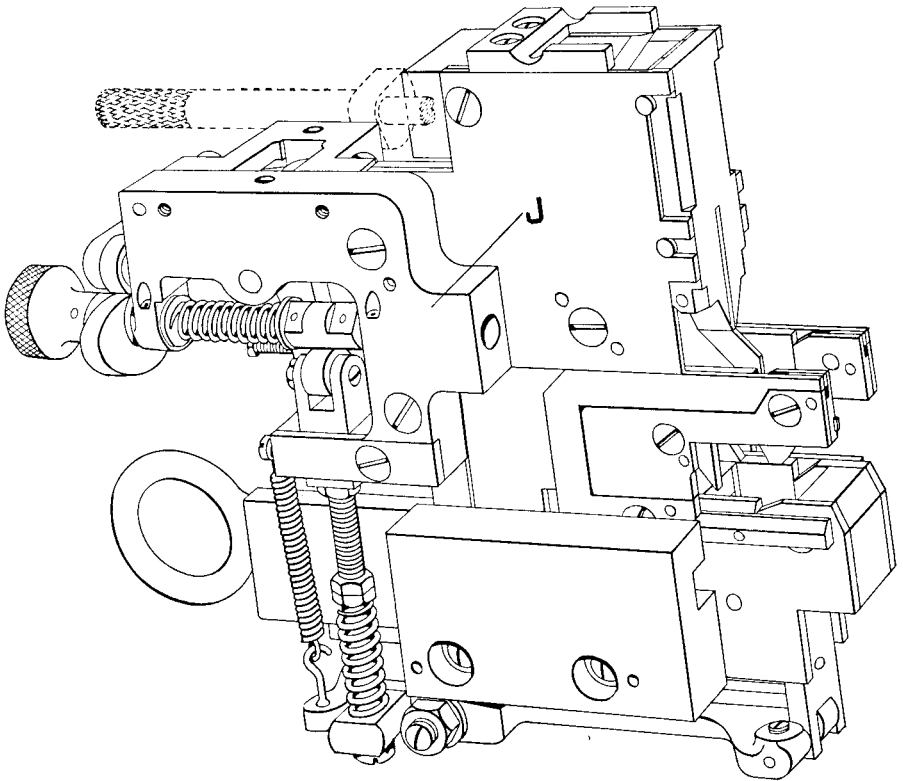

FIG. 131.—A perspective view of the new distributor box which has been adopted for use in the Models 25 and 26.

In the lower distributor boxes heretofore used on the Models 9 and 24, a beveled notch was required in the lower part of each matrix. In each distributor box there was a pair of pawls working vertically which cooperating with this beveled notch caused the matrices to be separated and delivered to the distributor screws one at a time. In the new distributor box the beveled notch in the matrices is not required and the pawls are replaced by other mechanisms.

One of the great advantages of the new box is that in the Models 25 and 26 a magazine can be taken from the Model 5, Model 8 or any model using the standard Model 5 magazine, and this magazine and its matrices can be used, as will hereafter be described.

In the Model 9 these lower distributor boxes have pawls which fit closely together and are operated much like an escapement. In the bottom at the center of all matrices used in these machines there is a beveled notch which comes down to a sharp edge. These pawls register with the beveled notch and by their action separate the matrices, delivering them to the distributor screws, one at a time. These lower distributor boxes are in use in many hundreds of Linotypes of the Model 9 type.

FIG. 131a.—A view of the inside of the distributor box, showing the path of the matrix as it comes from the primary distributor.

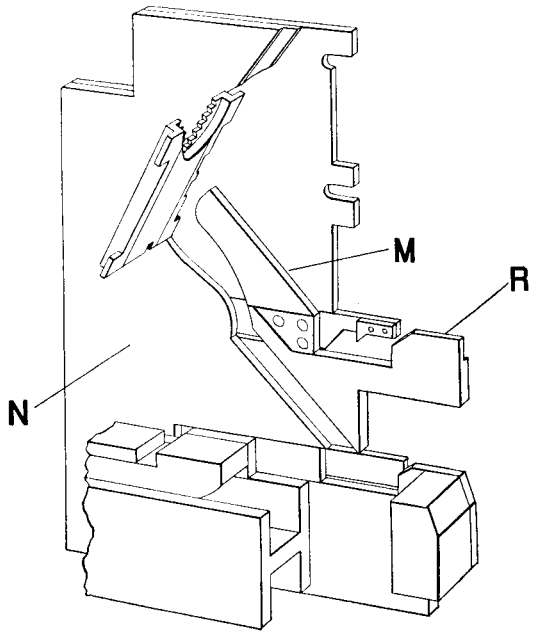
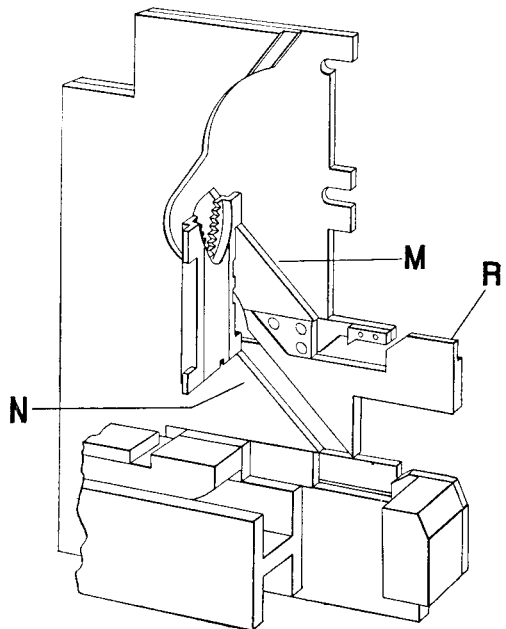

FIG. 131b.—Showing the matrix a little farther on in its descent. The top or long ear of the matrix is now riding on the rail *M*, while the lower ear is riding on the rail *N*.



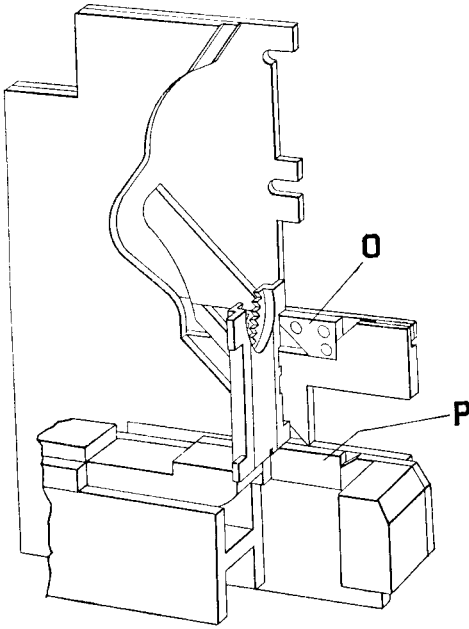

FIG. 131c.—Showing the matrix at the bottom of its descent and resting on the rails *O* and *P*.

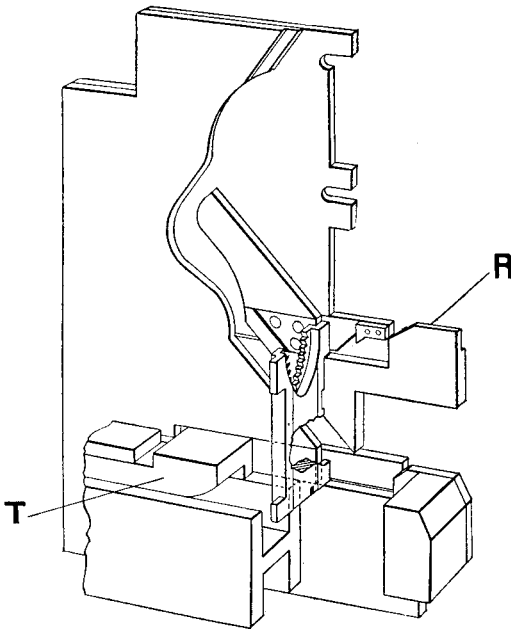

FIG. 131d.—Showing the rails *O* and *P* withdrawn and the matrix falling by its own gravity so that it rests on the rails *R*.

In the new distributor boxes the delivery of the matrix from the primary distributor to the lower box is substantially the same as formerly used. When the matrix is delivered into the box, however, instead of using pawls, the matrices are arrested in their fall and finally allowed to drop in front of four lugs mounted on two yokes. These yokes engage with the ears of the matrix instead of the body, as in the former distributor shifter lever. The lugs pushing the matrix by the ears bring these ears forward against the shoulders of the rails. An ordinary lift, exactly similar in its action to that used in the Linotype from the beginning, raises the matrix into the

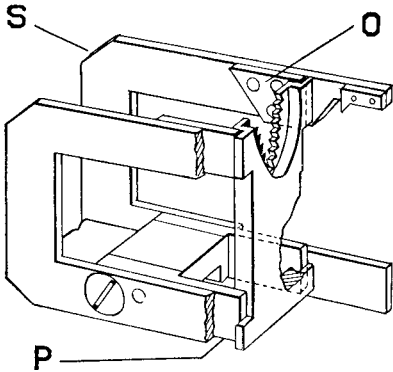

FIG. 131e.—Showing the matrix ready to be pushed forward by the rails *O* and *P*. There are two of these rails in each case, the upper and lower rails *O* and *P* being mounted on two yokes *S*. These yokes *S* are in turn mounted upon the slide *T*. The slide *T* is caused to reciprocate carrying the yokes *S* and the rails *O* and *P*, and pushes the matrix forward by the four ears against the shoulders of the rails *R*. At this time the matrix is in position to be raised by the lift.

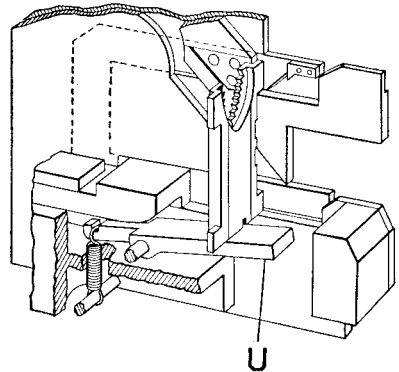

FIG. 131f.—Showing a small revolving member *U*. This is pivoted at its rear portion and is held up by a coiled spring. While the matrix is descending, this small coiled spring holds the member *U* up at a slight angle to the rails of the box. As the slide *T* goes forward it forces the member *U* down until it is horizontal with the floor and parallel to the rails. The object of this device is to prevent a very thin matrix from sliding down fast and turning or twisting in the box before the rails *O* and *P* come against the matrix.

distributor screws. The action of this box being much more positive than that of the pawls, has proved more satisfactory. A little dirt does not have so much tendency to make the box work badly. A circular describing in full the action of this box, with illustrations, can be obtained from the Company and is to be sent out with all Model 25 and 26 machines.

The cams *X* and *Z* are mounted on a shaft *I*. This shaft *I* is mounted in the bracket *J* on the side of the box. On one end of this shaft *I* there is a thumb screw and at the other end where it passes into the bracket *J*, the shaft has one-half of it cut away. This cut-away portion registers with a

similar portion of the distributor screw. This is shown in the cut-away portion in Fig. 130—G. The revolution of the distributor screw causes the revolution of the shaft *I* having on it the cams *X* and *Z*. It will be noted that this arrangement of the shafts *I* and the shaft of the distributor screw permits the whole distributor box to be removed and replaced. The shaft *I* also has a small longitudinal movement so that by taking hold of the thumb screw and pulling the shaft *I* away from the box the connection between the distributor screw and the shaft may be broken so that while the distributor screw continues to revolve, the shaft *I* will stand still.

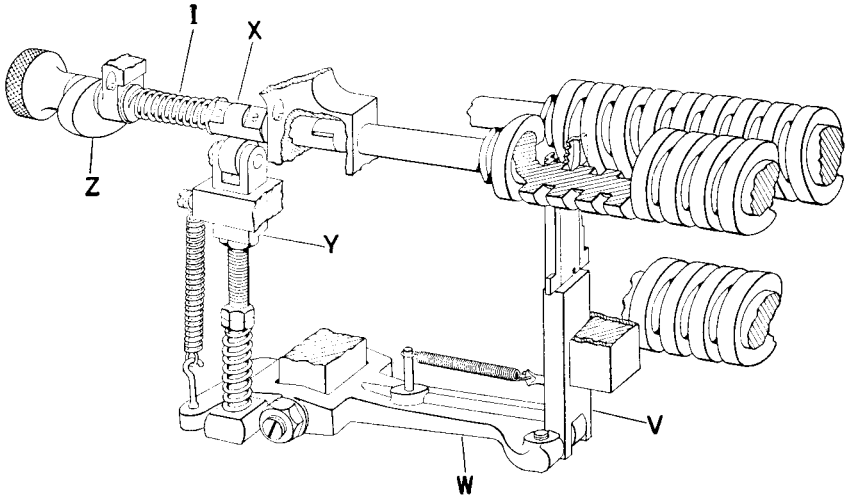

FIG. 131g.—A diagrammatic view showing the lift *V* mounted on the lever *W*. This lever *W* is caused to rock around its pivot by the cam *X* acting on the roller of the stud *Y*. The cam *X* is timed in the same way as the cams on all distributor boxes, so as to lift the matrix into the screws at the proper time.

It will be noted in general that the matrix which descends by gravity into the box is pushed forward positively into position and lifted positively into the screws in a manner similar to that used in the distributor boxes of the Linotype machine from the beginning. In the new box, however, the matrices are pushed forward by the ears instead of being pushed forward by the body of the mats in line, which are pushed by the distributor shifter. The action of the lift of the matrix into the screws is precisely like that of the ordinary distributor box such as is used in the Models 5 or 8.

In the distributor boxes used in the Models 9 and 24, the matrices which were separated by pawls acting on the beveled notch go downward and forward into the screws by gravity. In the new box the matrices are positively pushed forward by the slide *T* acting through the rails *O* and *P* so as to be brought in position to be lifted into the screws by positive action.

In the Models 25 and 26 the bracket *J* is on the side toward the front of the machine, while in the Models 9 and 24 the bracket *J* and its accompanying mechanism is on the rear side of the box. In other respects the boxes are exactly the same.

On the Models 25 and 26 the distributor screws which drive the shafts *I* in the two boxes revolve in opposite directions. *It is therefore impossible to transpose the box for the upper and lower distributors in the Models 25 and 26.* These boxes are numbered and there is a corresponding number on the bearings into which the boxes fit.

On the Models 25 and 26 when a box is to be removed *the distributor should be stopped.* Take hold of the thumb nut on the shaft *I* and turn the cam *Z* out of the way. This should be done on the box which is not being removed. The other box can now be removed and when replaced the distributor should be started, the box shoved into its position and locked. With the thumb nut the shaft *I* can then be turned and through the action of the spring mounted on the shaft, the shaft *I* will be connected with the distributor screw and the machine is then in operative condition.

PRIMARY DISTRIBUTOR—MODELS 25 AND 26

The primary distributor on the Models 25 and 26 is very similar to the primary used on older styles of plural distributor Linotypes, except that the dimensions on the rails on which the matrices rest when they are being carried to the chutes are somewhat different.

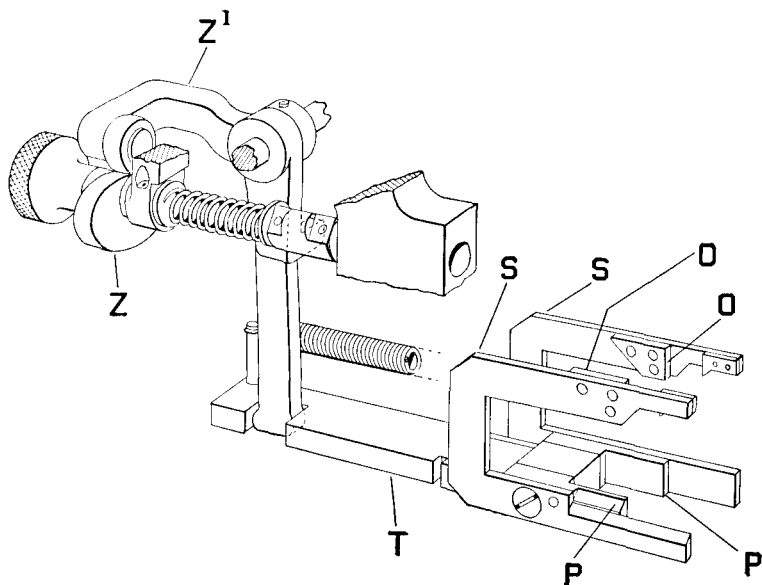

FIG. 131h.—A view showing the slide *T* carrying the yokes *S*, having mounted on these yokes the rails *O* and *P*, and the means for reciprocating the slide *T*. The cam *Z* working through the arm *Z'* causes the slide *T* to reciprocate.

There are two bridges used and the second one of these bridges is what is generally called a blank bridge. That is to say, there will be no projections upon it. The matrices that are intended to go into the lower magazine are notched in a manner similar to that in use in the Models 9 or 16. The matrices that go into the upper magazine, however, do not need to be notched when the blank bridge just mentioned is used.

This arrangement enables a customer to use any magazine of the Model 5 type and the matrices therein on the upper magazine of the Models 25 or 26.

In all ordinary cases the pi matrices used in either magazine need not be notched, but will be discharged from the second bridge, pass into the upper magazine, along the distributor bar and drop into the pi tube at the end of the bar and pass to the pi stacker.

There are some special cases, however, where both the pi and the matrices running into the upper magazine will need to be notched, and this arrangement can be provided when it becomes necessary.

In setting the lift which raises the matrices into the distributor screws, the cam *X* has a set screw in it and the cam is adjusted by means of the set screw, so as to lift the matrix into the distributor screws in exactly the same time and in the same way as is done on the Models 5, 8, or any single-distributor machine. When the matrix is lifted in the proper way, the cam *X* is pinned with a taper pin to the shaft *I* in the usual manner.

Very little oil is required and very little should be used on these distributor boxes. The bearings of the cam shaft and the levers should be oiled with a drop or two of clock oil. The yokes where they rub on the side of the boxes may be lubricated with a very little fine powdered graphite. The slide *T* can also be lubricated in the same way. After the boxes have run a few weeks and worn themselves in, a drop or two of oil once or twice a week on the pivot points and the bearings will be all that is necessary. While these boxes do not require cleaning as often as the boxes formerly used in the Models 9 and 24, they should be cleaned once or twice a week. When using oil or graphite, use as little as possible. It is very desirable that oil and graphite should be kept away from the matrices. This is important.

If clogs or stoppages of matrices in passing through these boxes occur, it will be found almost invariably that it is caused by the matrices being bent or the ears, especially of the thin matrices, being twisted. When such a clog occurs the offending matrix or matrices should be laid aside where it is possible, and examined, and if the ears are bent or damaged in any way they should be repaired before they are put back into the machine. This feature of the box is intentional because nothing is of greater trouble than a matrix having its ears bent and wedged into the channel of the magazine. It is far better that the matrix should be detected and stopped before it gets into the magazine.



*Care should be taken when one of these boxes is removed and replaced that it is firmly locked in position.*

Two thin matrices are prevented from being raised by the lift by a "bar point" which acts in exactly the same way as the bar point on other distributor boxes. These bar points, of course, have to be made very thin and they sometimes get bent and in time will wear and must be renewed. This renewal, however, should not take place oftener than once in two years. It is best, however, to always have on hand an extra one of these bar points so that if the one in the machine is bent or worn or broken it can be instantly replaced. In all these respects this bar point serves the same purpose and must have the same attention as the bar point on any Linotype machine.

#### LEAD AND RULE CASTER

This machine embodies the main features of the casting mechanism of the Linotype. It casts automatically rules, borders, dashes, blank slugs, two-point leads, etc. The machine is equipped with a water-cooled mold disk, and either two regular molds for casting rules, borders, dashes, etc., or two low-slug molds for casting blank slugs, leads, etc. Two molds only are furnished with the machine, the others being extra supplies. The lead and rule caster has a self-contained water-cooling device. This consists of a tank fitted inside the column of the machine, with an opening near the top and one near the bottom. When this is connected up with the mold disk in the usual way it will avoid the necessity of piping to the machine from some outside water supply. The difference in temperature between the water at the top and bottom of the tank will maintain a slow and constant circulation through the mold disk.

Both the molds for casting rules and the molds for casting leads which are furnished with the Lead and Rule Caster are hybrids, between the regular universal adjustable mold and the adjustable mold. They use the slot for the liner, the same as the universal adjustable mold, but they also use the two screws that were in the adjustable mold for holding the cap on the body of the mold after the liners had been placed in position. The thickness of the cap on the front face of the rule mold is the same as on the lead mold.

Matrix slide blocks of any length up to 30 ems can be used in the Improved Lead and Rule Caster. With a block shorter than 30 ems, it is, however, necessary to fill the space remaining between the end of the block and the vise jaws, either with another block or with matrices. The movable vise jaw on the Lead and Rule Caster does not close in on a short line of matrices or short matrix slide block, as is the case with the Linotype. We recommend the use of the full length block, 30 ems, using such length of slide in the block as may be necessary. This will involve the use of a blank filling piece, or pieces, of the same cross section as the matrix slide, and which can be furnished in any length up to 17 ems.

The lead and rule caster works automatically after the machine is started. It is necessary only to keep the metal pot supplied with metal,

and each machine is equipped with an automatic low metal alarm, which strikes a bell when the level of the metal in the pot gets below a certain point. Two molds of the same kind are required for casting either leads or rules, as the machine is so constructed as to cast from the molds alternatingly. The low mold for leads and the high mold for rules, borders, etc., are both adjustable from 2 to 12 points inclusive in thickness of body, and from 4 to 30 ems in length of slug. Slugs which are to be used as furniture are also easily cast.

The high mold, for rules, borders, etc., is designed for casting from border slides or from matrices which have the character in the auxiliary position. It is not possible, with this mold, to cast slugs from characters in the regular position on two-letter matrices, nor from one-letter matrices with the character punched in the regular position. This is on account of the thickness of the lip of the mold cap. Special matrix slide blocks with the slide in the position corresponding to the auxiliary position of the two-letter matrix are required.

If it is desired to cast slugs from the regular character of two-letter matrices, or from one-letter matrices with the character punched in the regular position, or from matrix slides used in the ordinary matrix slide block with the slot in the regular position, it will be necessary to substitute the parallel universal adjustable mold, which produces a slug that is parallel and ribless, and is adjustable from 5 to 14 points, inclusive, in thickness of body.

It is possible to cut two regular Universal mold pockets in addition to the two Lead and Rule mold pockets, making a four-mold disk on the Lead and Rule Caster. When this is done, use the parts for operating the vise automatic which we use in the regular four-mold disk.

*Caution:* Four molds (two of them universal and two of them rule molds) can be used in this four-mold disk, and changed from rules to universal molds, or *vice versa*, by simply revolving the disk. It is not possible, however, to do this when using the lead molds or low molds, because the mold disk is advanced, and in this case the universal molds would have to be taken out of the four-mold disk and replaced by dummies, as the full-height molds would strike upon the jaws or the knives when using the lead or low molds. It seems, therefore, not expedient to use the four-mold disk on the Lead and Rule Caster.

The low mold used in this machine is somewhat different from our regular low mold. The height is the same, but the regular low mold is provided with a rib, or projection, which prevents the face of the mold being wiped and interferes with the casting of leads against the movable vise jaw, which is the approved method when using this machine. It would be possible to use the regular low mold in the Lead and Rule Caster, but the results would not be as good as may be obtained with the special low mold for this machine.

Matrix slides can be furnished for casting either on 2 point body or in the center or on the edge of larger bodies.

A special matrix slide block, 30 ems long, should be used in the lead and rule caster. This special matrix slide block has the slot on one side to accommodate the slide in the regular position, and on the reverse side has the slot in a position corresponding to the auxiliary position of a matrix. Thus, the block serves the purpose of casting from either position. These blocks are always carried in stock.

*Do not attempt to use a short slide in a 30-em block without filling up the balance of the slot with a blank slide. If you do you will get a very bad squirt.*

The liners for both the rule and lead molds used on this machine are special. These liners are parallel and lack the .003 of an inch taper of the regular Universal Adjustable liners.

Regular ejector blades are used for slugs 5 points or more in thickness; these blades can be used with either high or low molds; for slugs thinner than 5 points special ejector blades and guides must be used.

*Ejector Blades and Ejector Guides.*—To protect and strengthen the thin ejector blades when casting slugs thinner than 5-point, it is necessary to use rigid ejector-blade guides. Therefore, to equip machine for casting 2-, 3-, or 4-point leads and rules, use special spring or guide plate in knife block; also special ejector-blade guide blocks in mold slide. When casting 5-point or over, use ejector blade, guide F-353.

*Use short ejectors when using low-slug molds.*

*Low Leads and Slugs.*—When casting low leads and slugs, advance the mold disk by means of the lever provided for that purpose; also advance the metal pot by turning eccentric pin in pot lever from R to L. Remove the first-elevator back jaw.

*Matrix Blocks and Slides.*—When using matrix slide blocks with the special high-slug mold, place the matrix slide in lower position in block, and place block in regular position in first-elevator jaws. Also use two-letter attachment on vise cap.

When using the matrix slide block with the regular Universal mold or with the parallel mold, the slide may be used in regular position in the block and the block in the regular position in the first-elevator jaws without the two-letter attachment on the vise cap.

*Border Matrices.*—One-letter border matrices cannot be used with special high-cap mold. If border matrices are used with this mold they would necessarily have to be two-letter matrices, and cast from the auxiliary punchings.

*Casting from One Mold Only On Lead and Rule Caster.*—If for any reason it is desired to cast from one mold only, remove the mold-turning segment, which has but seven teeth, and attach mold-turning long segment, which has teeth full length. This change causes the disk to make a

complete revolution, instead of a half revolution, as is the case when casting from alternate molds.

*Gas-Pressure Governor.*—It is advisable to attach an extra gas-pressure governor to the supply line for the Slug Caster, in addition to the main plant governor, as it is often necessary to regulate the heat for this machine differently from the regular machines.

*Casting 13-Em Lines from Border or Other Regular Matrices.*—Blank out balance of the line with the 17-em matrix quad block, or matrix quads.

The reader may think that in the directions given there are a very large number of points to be noted. This is correct. This fact, however, is not the fault of the Linotype Company, but is due to the fact that the printing art as now practised contains an infinite number of small details in furniture, type, rules, size and dimensions of borders, etc. Our customers are respectfully urged to remember the above statement and to be sure that in ordering they state explicitly and distinctly everything desired in the particular part or parts that are ordered. It is only by taking especial pains in this matter that mistakes and exasperating delays can be avoided.

If our customers will take a little time and special care in ordering supplies or special matrices, matrix slides, molds for casting leads, etc., they will save themselves and the Linotype Company much expense and vexatious delay. The number of specialties used on the Linotype is very great and increasing constantly.