

# LINOTYPE MAINTENANCE MANUAL

*Including*  
The Big Scheme  
of Simple Operation

TRADE **LINOTYPE** MARK

**LINOTYPE · BROOKLYN 5, N. Y.**  
NEW YORK · BOSTON · CLEVELAND · CHICAGO  
ATLANTA · DALLAS · SAN FRANCISCO · LOS ANGELES  
CANADIAN LINOTYPE, LIMITED, TORONTO, CANADA

“CARELESSNESS DOES  
MORE HARM THAN A  
WANT OF KNOWLEDGE”

—*Benjamin Franklin*

FOURTH PRINTING

This book is set in Linotype Bookman and Linotype Textype.  
Display throughout is in members of the Linotype  
Memphis family.

COPYRIGHT, 1951, BY MERGENTHALER LINOTYPE COMPANY  
REPRINT ONLY BY PERMISSION. PRINTED IN THE U. S. A.

---

# THIS BOOK

---

For more than half a century LINOTYPE has maintained a policy of sharing the technical experience of engineers, plant machinists, operators, and typographers with Linotype users everywhere.

This book has been compiled in the interest of maximum production with minimum waste and delay, through continuous, uninterrupted operation.

The helpful hints are intended to assist Linotype users in diagnosing troublesome conditions if they develop. They represent the best judgment of Linotype technical experts from here, there and everywhere although no pretense is made that in some cases there may not be other remedies. Nor are these brief comments to be considered as comprehensive discussions of the mechanics or maintenance of Linotypes. Competent Linotype machinists devote lifetimes to studying and developing newer and better methods of maintenance, frequently with consequent improvement in production, both in quantity and quality.

*The Big Scheme of Simple Operation* has been previously printed in booklet form and is included here as a brief and graphic story of what the Linotype is and of the principles of its operation in the belief that it will prove of interest to many readers.

---

---

# CHAPTERS

---

	PAGE
The Big Scheme of Simple Operation . . . . .	5
<p>A brief, illustrated story of the Linotype and how it operates. Told in a manner which is not too technical for students and newcomers in the field of graphic arts to understand the mechanics of machine composition.</p>	
The Care and Maintenance of Matrices . . . . .	41
<p>A discussion of the proper use and care of Linotype matrices, including a list of "Do and Do Not" suggestions of value to users.</p>	
Lubrication, Routine Checkups and Cleaning . . . . .	51
<p>Illustrations show the oiling points on current Linotype models. The description of routine checkups and cleanliness includes detailed programs of proper inspections.</p>	
Assembling . . . . .	72
<p>Descriptions and drawings systematically cover the operation and care of the assembling section of the Linotype.</p>	
Casting . . . . .	94
<p>This chapter describes the functions of casting, after the matrices have been assembled. Adjustments and maintenance suggestions are given in detail.</p>	
Distribution . . . . .	132
<p>Following casting comes the distribution of matrices. A careful discussion of maintenance and adjustment problems is included in this chapter.</p>	
Driving . . . . .	156
<p>The principles of Linotype driving power and control. Suggestions concerning maintenance and adjustments.</p>	
Adjustments . . . . .	160
<p>Fifty of the most important adjustments on the Linotype have been compiled and assembled here for quick reference.</p>	
Index . . . . .	167
Two Books Every Printer Needs . . . . .	170
<p>An announcement and description of two books which every printer, operator, machinist, apprentice and student of printing should own.</p>	



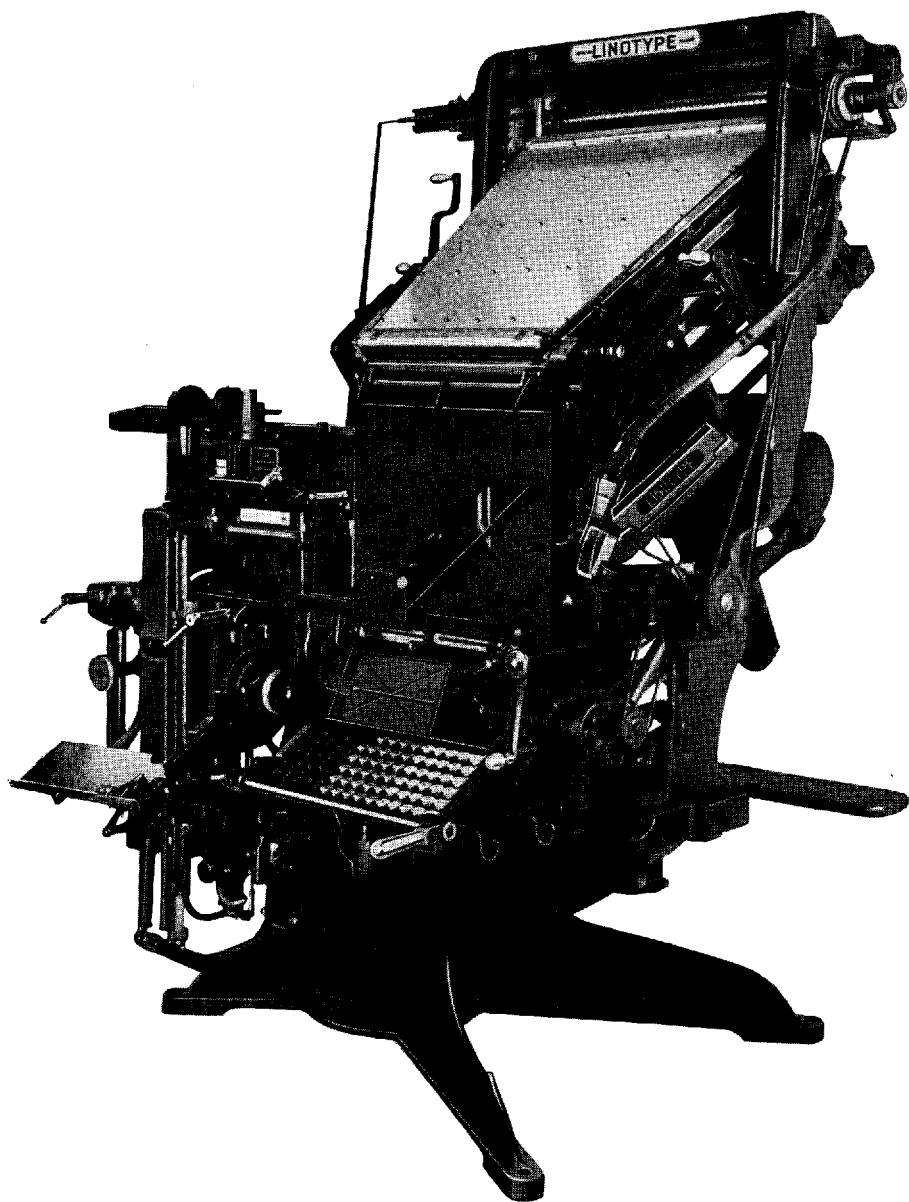

FIG. 1-1. A Model 31 four-magazine Linotype. Many of the detail illustrations in this book are based upon this model. There are variations for specific purposes in other models, but the big scheme of simple operation applies to every Linotype.

---

# THE BIG SCHEME OF SIMPLE OPERATION

---

## *What the Linotype Is*

**T**HE LINOTYPE is not a type-setting machine. No types are used in it. It composes with matrices—small brass units having characters indented in the edges—hence the name “matrix.” These matrices are assembled into justified lines. From the matrix line the Linotype automatically casts a solid bar, or line, of type. This bar is known as the Linotype slug. It is ready for use when it leaves the machine.

The Linotype has four major divisions:

1. *The Magazines which contain the matrices.*—They represent type cases. Because every matrix circulates automatically back to its place in the magazine as soon as it has served in a line of composition, a font of matrices is small in number compared with a font of type. A magazine is so compact and light that the operator can handle it without exertion, and can produce a variety of composition by simply changing magazines.

2. *The Keyboard and its related parts.*—This controls the release of the matrices from the magazine in the order in which the characters are desired. The Linotype operator, from his seat at the keyboard, has complete control of every function of the machine. His duties are limited merely to operating the keyboard keys—justification and distribution are mechanically automatic.

3. *The Casting Mechanism.*—This division of the machine makes the Linotype-equipped printer his own type-founder. The justified line of matrices is presented automatically to the casting mechanism, molten type-metal is forced into the indented characters on the edges of the matrices, and the cast line, a single unit with a new type-face, is delivered to the galley on the machine, precisely trimmed and ready to go into the form.

4. *The Distributing Mechanism.*—When a line of matrices has served for casting the line of type, it is lifted automatically and carried to the top of the magazines, where, by a simple though ingenious system, each matrix is delivered to its proper place in the magazine, and is ready to serve again. Thus in the Linotype-equipped shop there is no distribution of type.

The small piece of brass shown in Fig. 4-1 is the key to everything the Linotype does. On the edge you will see indented characters. It is from these that the raised printing characters are cast on the face of the Linotype slug.

The Linotype is, in simplest terms, a machine for (1) assembling a number of these matrices in a row, or line; (2) automatically spacing that line to a desired length; (3) holding the indented characters of this line up against a casting mechanism of which they become a part and which molds the line of printing characters.

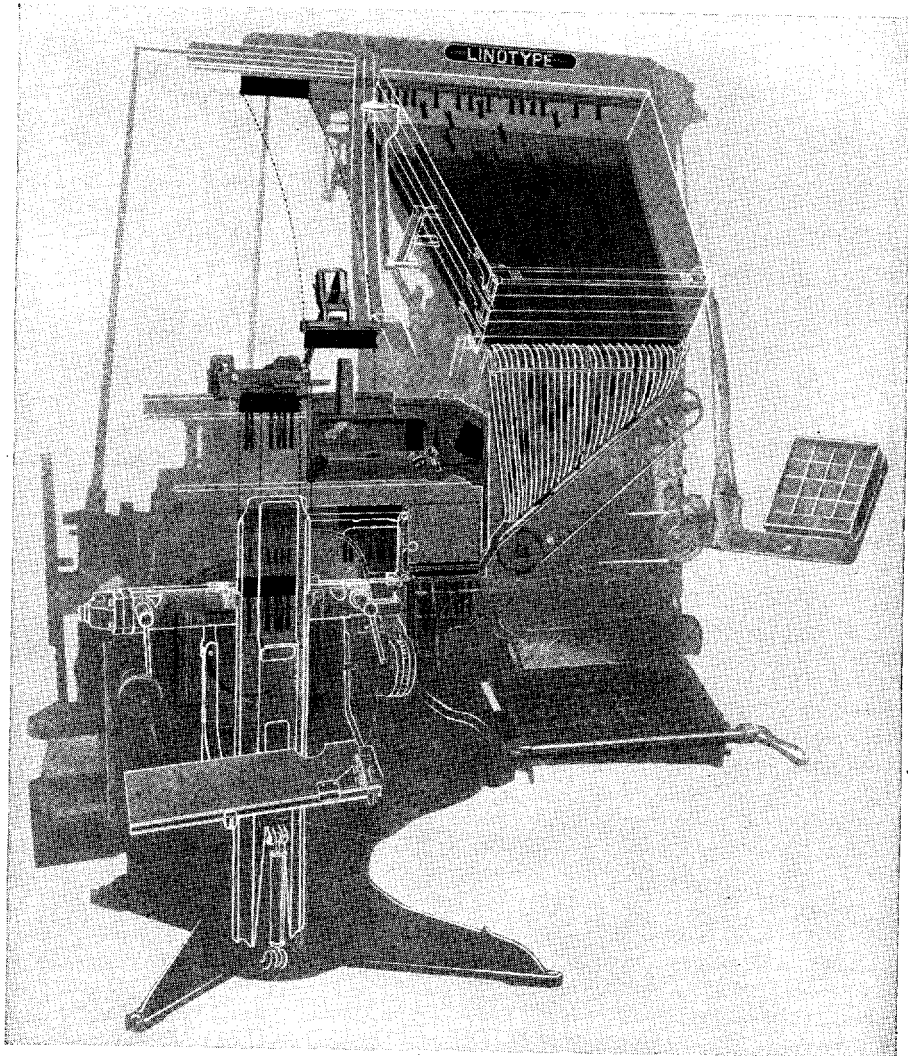

FIG. 2-1. Phantom illustration showing each stage of the circulation of the matrices through the Linotype.

ters on a bar or slug; and (4) transferring this line of matrices to their original positions in the magazine (see Fig. 6-1) where they may be used again. All these operations are automatic.

Note the teeth at the top. Each character has a different set of teeth. These guide it back to its proper place for repeated use.

The Linotype Company carries a stock of many millions of these matrices. Each of them requires an average of seventy different operations of extreme precision and careful inspection during the course of manufacture.

The spaceband consists merely of two thin wedge-shaped pieces of metal. They taper in opposite directions so that the outside faces are always parallel.

One of these will make a space between two words. Whenever the operator wants a space, he touches a special key on the keyboard, which makes one of these spacebands drop into the row of matrices.

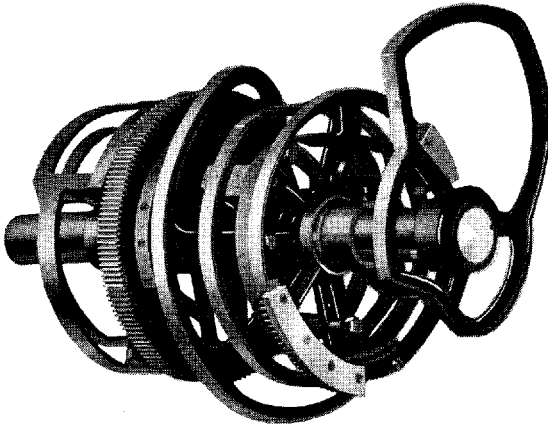

FIG. 3-1. The cams assembled on the shaft actuate and control most of the mechanical actions of the Linotype. A one-third horse-power motor drives the entire machine.

When the operator has assembled a line of matrices and spacebands, he sends it to the casting position. A bar rises and presses against the bottom of all the spacebands in the line and automatically justifies the line to the proper length.

This occurs because the upper part of each wedge is held firmly while the lower part rises and widens the space as needed.

After the casting operation they are automatically returned to the original position, and are, of course, used over and over again.

Fig. 8-1 shows spaceband as it drops into the row of matrices. Notice that the bottom of the spaceband is beveled so that it will strike the matrix a glancing blow as it arrives, without causing damage to the matrix.

Fig. 9-1 shows a row of composed matrices and spacebands as they are assembled by the Linotype. The spacebands are shown partially raised to emphasize their function. With spacebands dropped, the line is ready to move over in front of the mold where the Linotype slug (shown in Fig. 10-1) will be cast from them.

These matrices and spacebands are assembled in a "stick" which holds them in a row until the line is complete. This "stick" is called the assembling elevator, and is shown in Fig. 27-1. Fig. 26-1 shows another view (greatly enlarged) of the elevator alone, and indicates how matrices are aligned for proper positioning.

A Linotype slug—a bar of metal with raised characters on its printing edge—is shown in Fig. 10-1. It is cast in the mold shown in Fig. 30-1, and this is the "line o' type" from which the Linotype gets its name.

The Linotype is a machine for manufacturing these slugs. It does this by assembling a line of matrices and spacebands (as shown on page 10, Fig. 9-1) and holding them against the mold into which molten metal is forced, producing the cast slug as shown in Fig. 10-1, page 10.

Six lines can be assembled, cast and distributed by the Linotype while one line would be set by hand, one-type-at-a-time. And after the slug is used it does not have to be distributed as does hand type. It is simply remelted and used again and again. The Linotype produces new

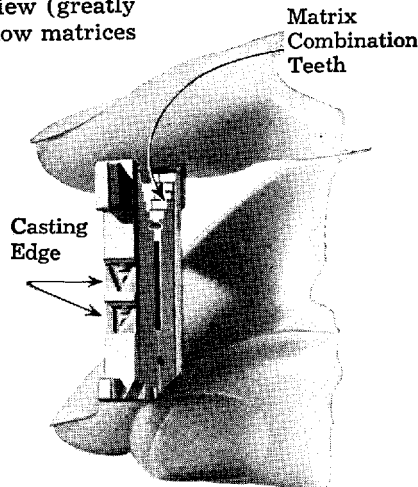

FIG. 4-1. The Linotype matrix.

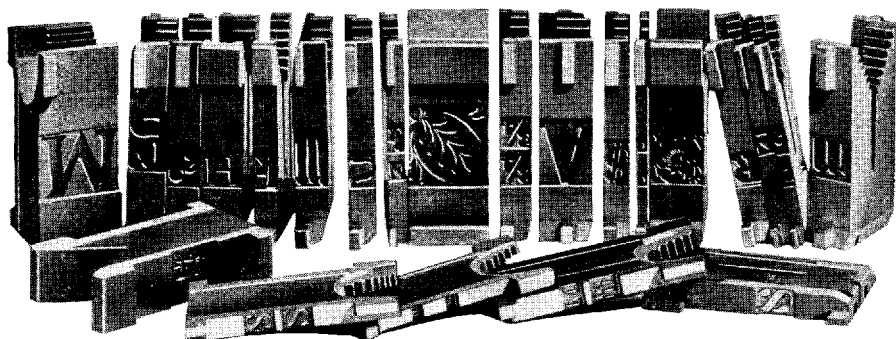

FIG. 5-1. A few matrices of a wide variety of characters commonly used in printing. They are made in sizes from 4 point to condensed 60 point.

type matter, then, for every job, which, of course, improves the printed appearance because of its correct height and clear, sharp surface.

Linotype slugs are much more easily handled than single type. It is possible to pick up 50 or more of them at one time without pi-ing, so that make-up is simplified. Corrections in Linotype composition are made more expeditiously than in any other matter. Errors of omission through dropping or pulling out of single characters are entirely prevented.

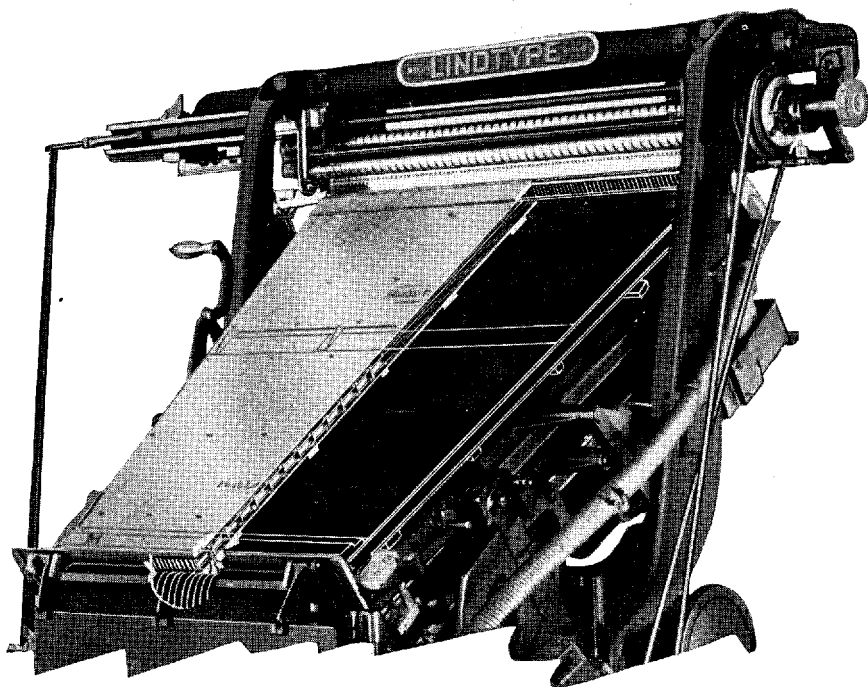

FIG. 6-1. Linotype matrices are stored in magazines, from which they are released as explained on page 9. In this illustration the upper magazine has been cut away longitudinally to show all matrices of one character in "channel" which retains them.

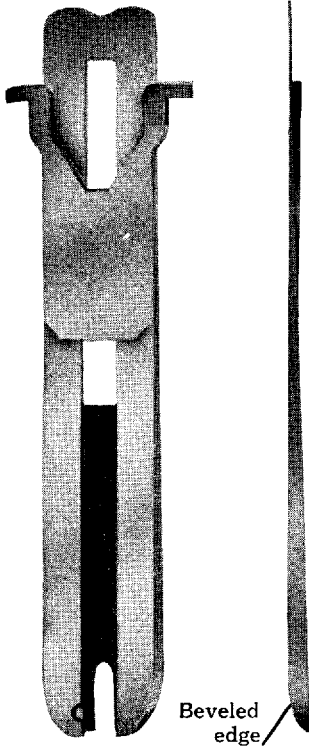

FIG. 7-1. Front and side views of the Linotype spaceband.

When the operator presses the key, it releases the trigger 2 and allows the cam to drop onto the rubber roller 4, which rotates the cam and thereby makes the cam yoke 5, operate as a lever. The inner (right-hand) end of the cam yoke raises rod 1. The outer end remains in its regular position. When the cam has turned completely around, the cam yoke is caught up on trigger 2 again, to await its duty.

There is one of these devices for every key on the Linotype keyboard. They are in two rows just at the top of the keyboard. A section of the rows appears in Figs. 17 and 18-1.

The operator merely "starts something" when he lightly touches a key on the Linotype keyboard. By tipping the trigger 2 he starts a mechanical process which releases a matrix. This enables him to touch keys as fast as his fingers will travel. The average is about 150 matrices a minute.

Large faces as well as small are set on the Linotype in modern composing rooms. Fig. 13-1 shows a Linotype slug of large face with a body that is partly hollow (or recessed). Large slugs are cast this way to save metal and decrease weight.

When the operator touches one of the keyboard keys, the desired character is immediately released. Or if he touches the spaceband key, a spaceband is released and dropped.

The keyboard is built and arranged for speed and ease of operation. The keys for characters most frequently used are within easiest reach. The keyboard is set at the proper slope for the comfort of the operator's hands.

Only the lightest touch of a key is required to release a matrix or a spaceband.

When the operator touches a key of the Linotype, his action is transmitted into an upward push on rod 1, Fig. 16-1, which operates an escapement to allow the matrix to drop.

The action of the device shown in Fig. 16-1 is to transmit the operator's downward key pressure into the right kind of upward pressure.

This upward pressure is a correctly timed pressure, quite different from the human irregular pressure of the operator on the key. The cam device, 3, Fig. 16-1, is one of the things that makes the Linotype so smooth-running, so satisfactory and simple in its continuous operation over a period of years.

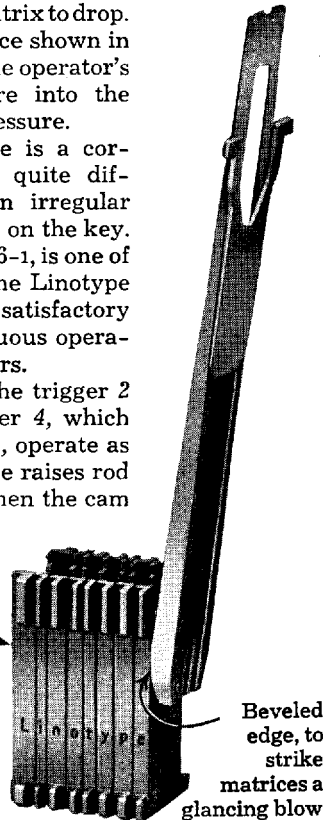

FIG. 8-1. View of spaceband dropping into line of matrices.

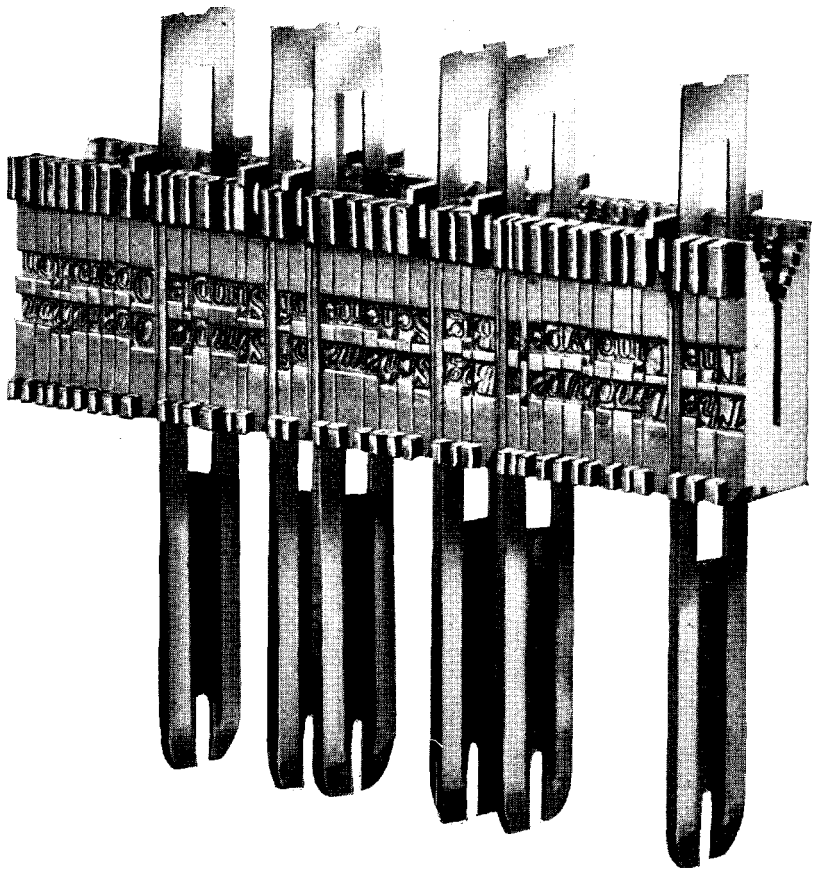

FIG. 9-1. A line of matrices and spacebands.

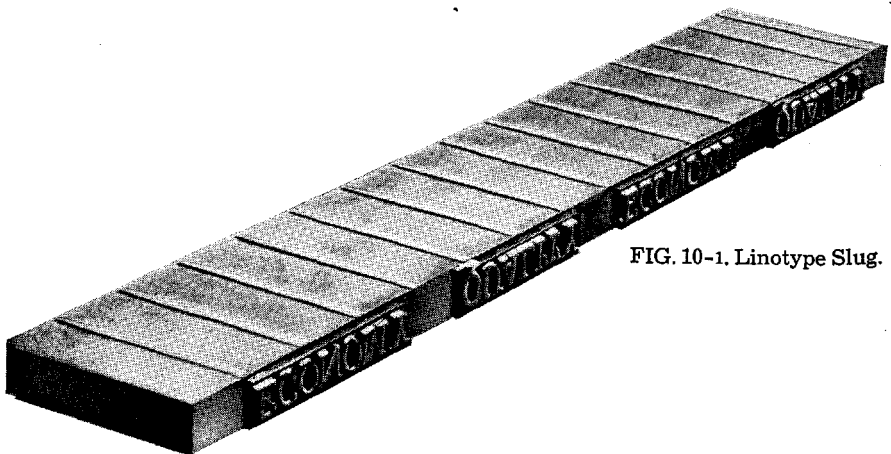

FIG. 10-1. Linotype Slug.



FIG. 11-1. Simplicity of handling has established the Linotype slug as the modern unit of composition.

In the illustrations Figs. 16 to 20-1 one cam is shown. Since there is one cam for every key on the keyboard, they extend entirely across the top of the keyboard in two soldier-like rows, one behind the other.

The operator can get at them by simply turning down the spring bar 1, to the position shown in Fig. 18-1. Thus the entire mechanism is made easily accessible.

Fig. 19-1 shows a cam removed from the keyboard. All that is necessary to remove one of the cams from the row is to press down on its corresponding key on the keyboard. Then the ordinary action of the cam will raise the yoke up out of the row so that the cam may be easily and simply lifted from its place with the fingers. No tools whatever are needed for this removal. Cam yokes in the back row are just as easily removed as those in the front row.

Fig. 20-1 shows the path of action started by the touch of the finger on a Linotype key. In this illustration, 1 is the Linotype matrix, ready to be released; 2, the escapement mechanism described on this and page 13. 3 is the cam frame described previously and illustrated in the enlarged views, Figs. 17 and 18-1. Also indicated are the magazine, channel entrance, and a matrix at the distributor bar.

The finger touch is transmitted toward the "top of the picture" by the rods, levers, etc., shown in this illustration and every one of these parts has a distinct purpose. *Every part of the Linotype is there because the machine is better for it, and all parts fit into the big scheme of simple operation.*

This picture leads us upward from the cam mechanism, to the escapement mechanism which in turn operates to release the matrices from the magazine in which they are stored.

Fig. 21-1 shows the mechanism which releases the matrices from their channels. It is called the escapement.

When the operator touches a key on his keyboard, 1 rocks and makes two small pawls, 2 and 3, slide up and down. When 2 slides down, the matrix drops.



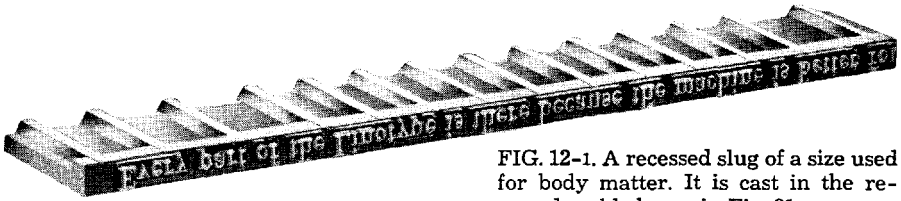

FIG. 12-1. A recessed slug of a size used for body matter. It is cast in the recessed mold shown in Fig. 31-1.

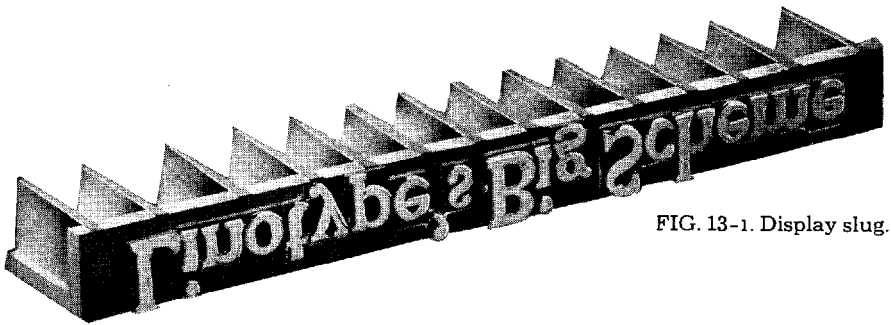

FIG. 13-1. Display slug.

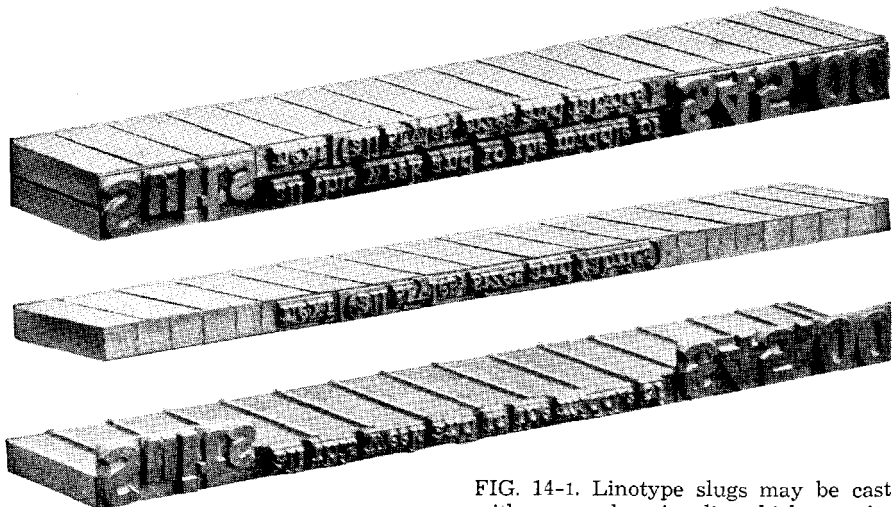
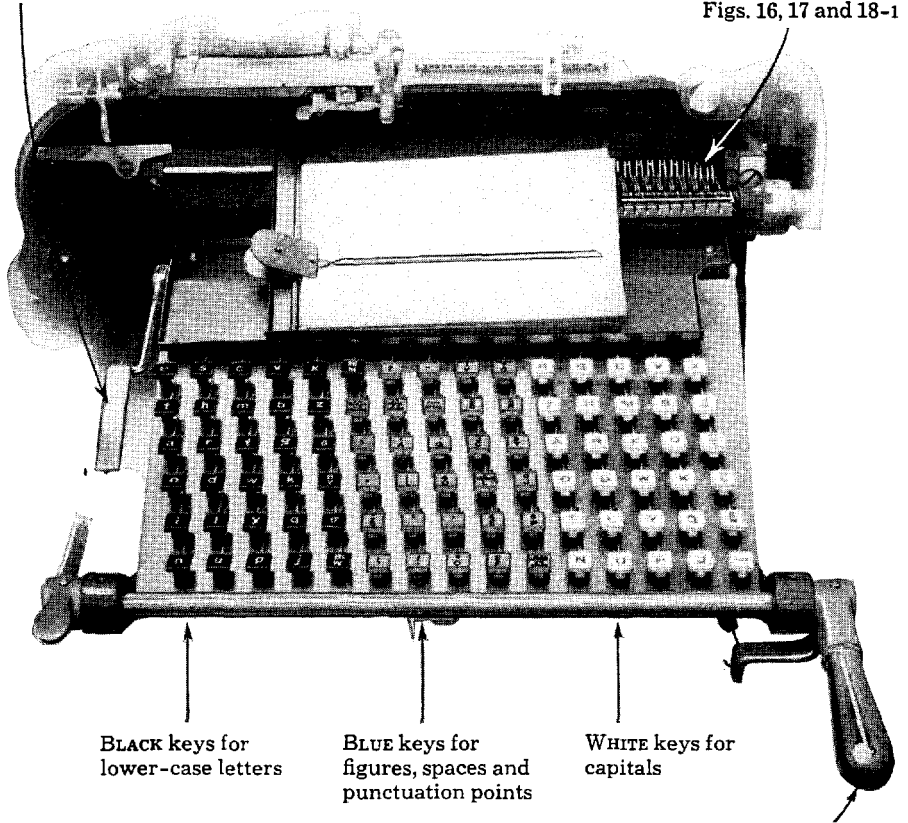

FIG. 14-1. Linotype slugs may be cast with an overhanging lip which permits large characters to lap over one or more adjacent slugs. The upper section of this illustration shows such a combination, and the lower, the two slugs separated. The mold in which they are cast is shown in Fig. 33-1.

When this key is touched a spaceband drops

Row of keyboard "cams" shown in Figs. 16, 17 and 18-1



BLACK keys for lower-case letters

BLUE keys for figures, spaces and punctuation points

WHITE keys for capitals

This lever raises the assembling elevator

FIG. 15-1. The Linotype keyboard.

At the same time, 3 catches the second, or oncoming matrix and holds it until 2 can slide up again to catch it. 2 and 3 "see-saw."

There is one of these escapements for each channel in the Linotype magazine. They are all in a row, usually not attached to the magazine. They can be lifted lightly off the machine in a neat frame, as shown in Fig. 23-1.

4 and 5 are solid, stationary pieces of metal which act as braces below the parts 2 and 3, so that the continual impact of matrices against the pawls will not wear, bend or loosen them.

The part illustrated in Fig. 23-1 contains the same number of escapements (shown individually in Fig. 21-1) as there are channels in the magazine. It is usually a part of the machine and is therefore not removed when one magazine is substituted for another. This construction lightens the weight of a magazine, safeguards it against abuse, damage in handling and dirt, all of which are responsible for transpositions and other preventable errors in composition.

When the escapement pawls release matrices, the matrices drop through the guides shown in Fig. 22-1, upon the moving assembler belt and are hastened down into the "stick," or assembling elevator 6, to the left of the bottom pulley.

A small spring 1 at the bottom of the belt gently breaks the speed of the falling matrices. This is called the "chute" finger and is illustrated in detail in Fig. 24-1.

There is a little star-shaped wheel 2, Fig. 22-1, of fiber which pushes the matrices into a line and holds them upright. This is the star-wheel. If the operator accidentally oversets a line and too many matrices come down, the star wheel ceases to turn and ceases to push automatically—another instance of the Linotype's almost human intelligence and self-protection.

By pushing a knob 3 at the right of the lower pulley the operator can instantly stop the belt, so that he can, if necessary, remove any surplus matrices from the bottom of the chute.

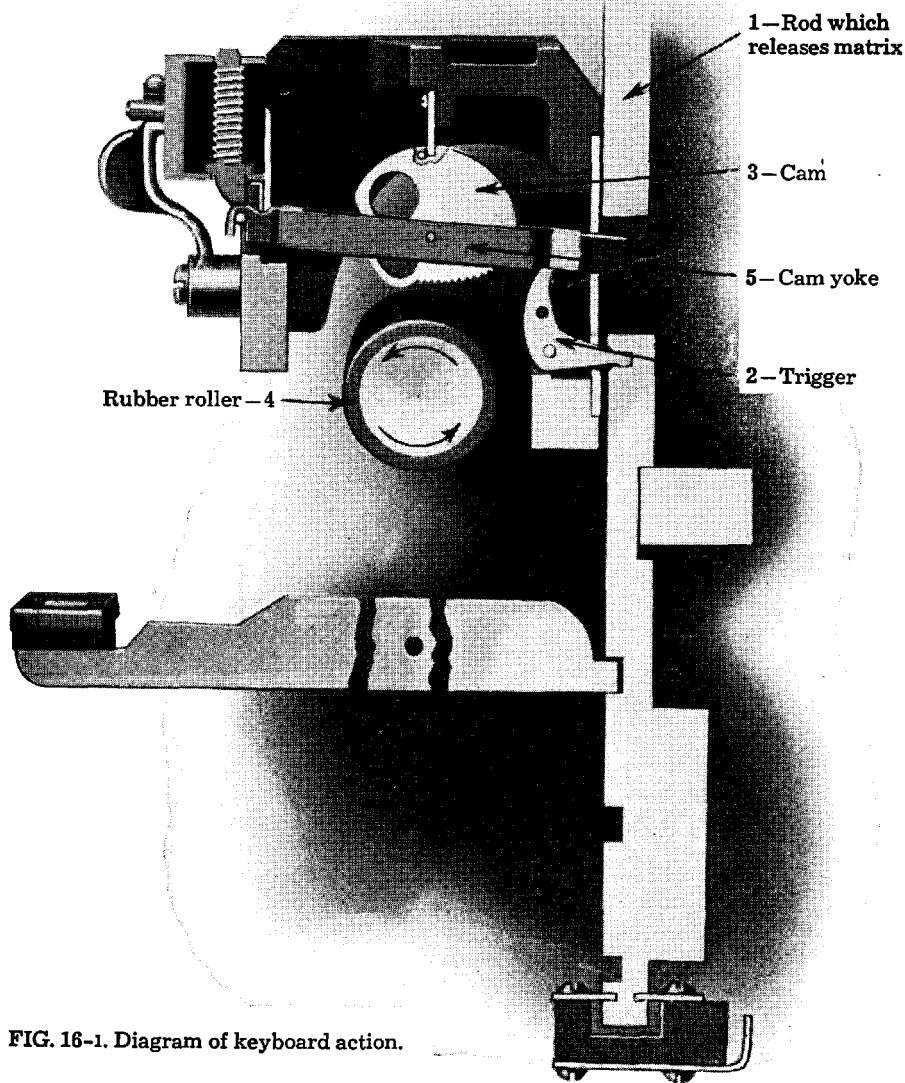

FIG. 16-1. Diagram of keyboard action.

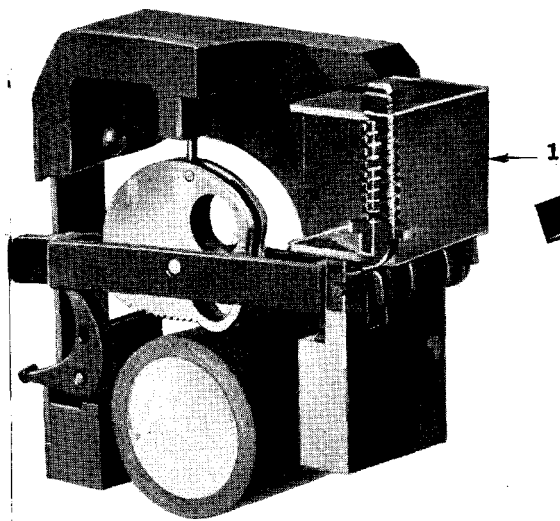

FIG. 17-1. Section of the keyboard cam frame.

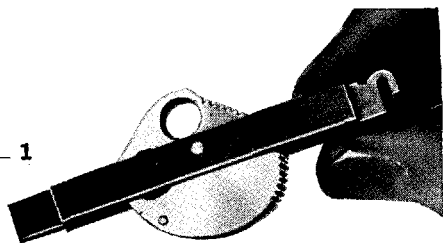

FIG. 19-1. A keyboard cam and yoke.

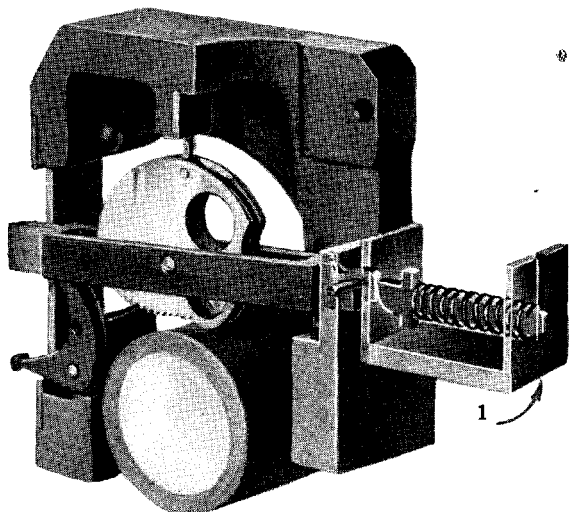

FIG. 18-1. Another section of the keyboard cam frame with spring bar open.

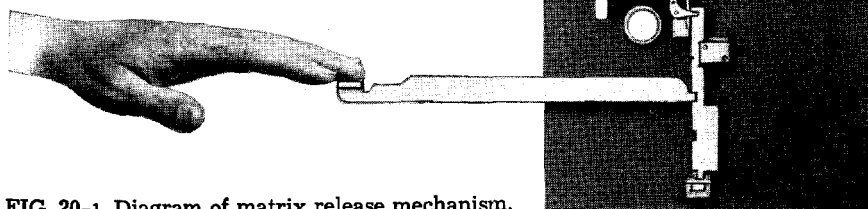

FIG. 20-1. Diagram of matrix release mechanism.

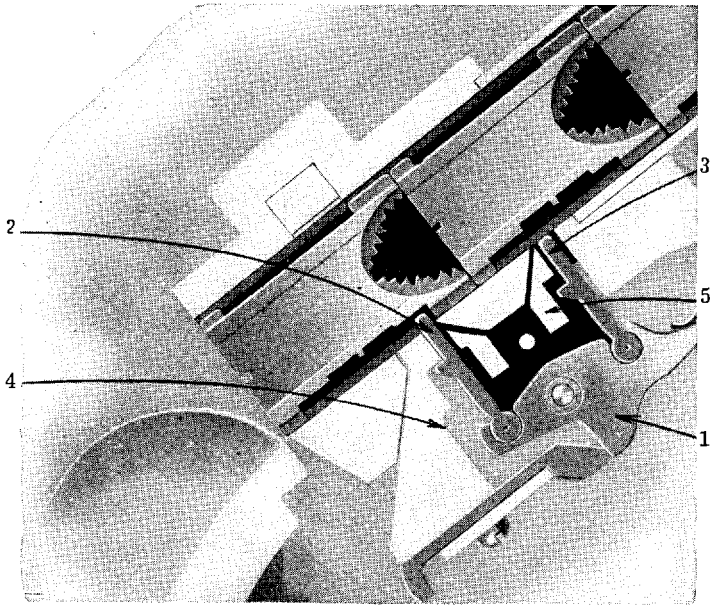

FIG. 21-1. The escapement mechanism.

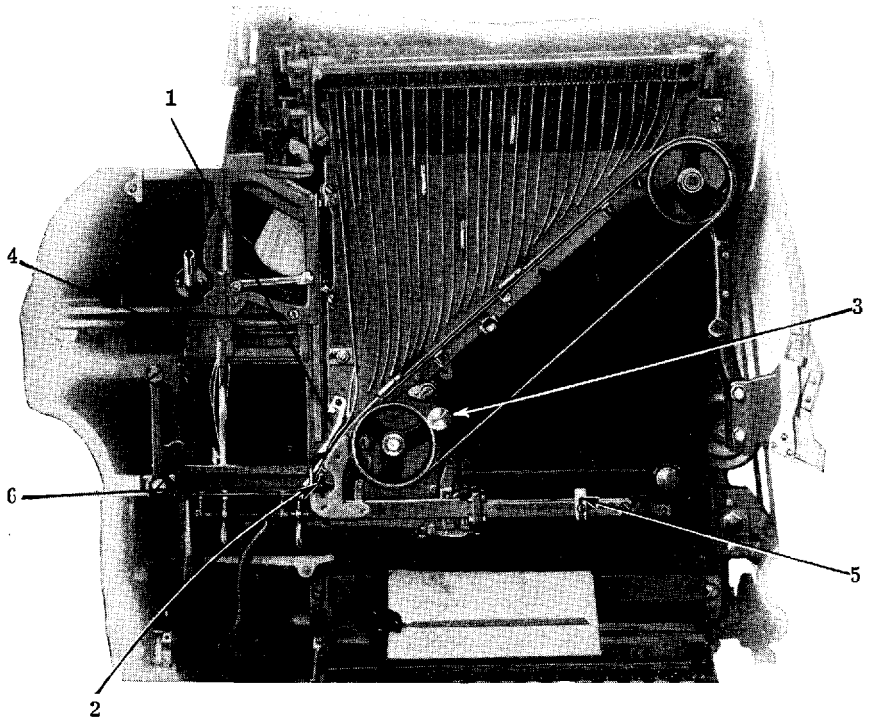

FIG. 22-1. View of assembler entrance.

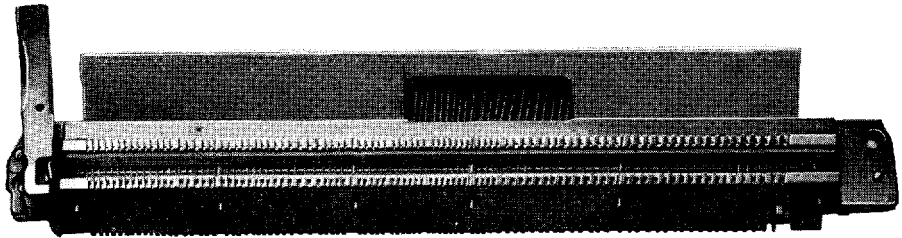

FIG. 23-1. An assembled escapement.

2

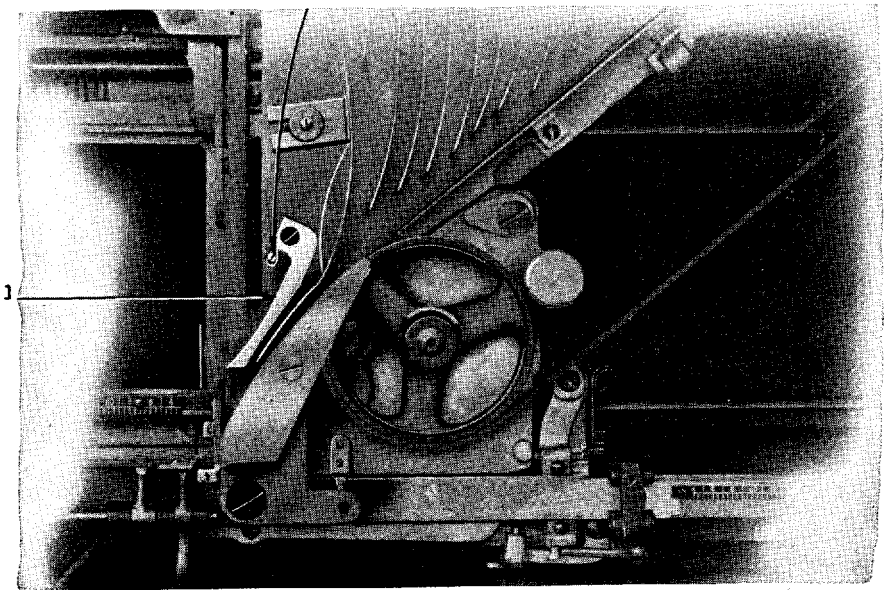

FIG. 24-1. The chute finger.

A change of measure in the assembling elevator 6, or on the delivery slide (the line-carrying device immediately above the assembling elevator), can be easily and quickly brought about by a slight pressure on, and a horizontal movement of, the stops 4 and 5.

The swift downward flight of the Linotype matrices is restrained at the bottom of the belt and rails by the finger 1, shown above, and known as the chute finger. A small tongue on the chute finger is held by spring pressure against a projecting stud 2. The angle at which the tongue rests on this stud determines the adjustment of the chute finger for various thicknesses and sizes of matrices.

On most of the Linotype matrices up to and including 14-point, and on all Duplex Display matrices, there are two letters or characters. That is, most matrices can



FIG. 25-1. The upper character is cast when the matrix is riding on the bottom rail of the "assembling" mechanism.

The lower character is cast when the matrix is riding on the top rail of the "assembling" mechanism.

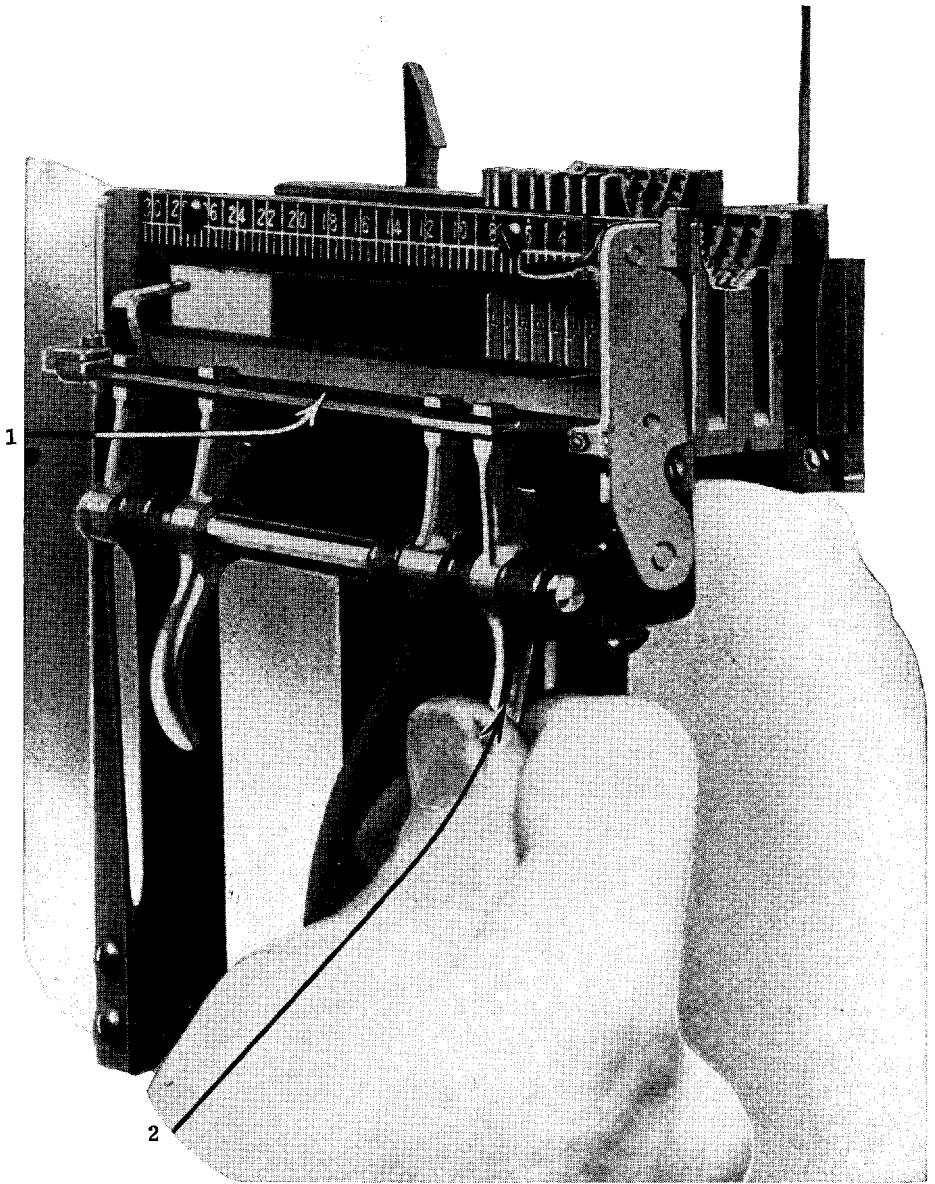
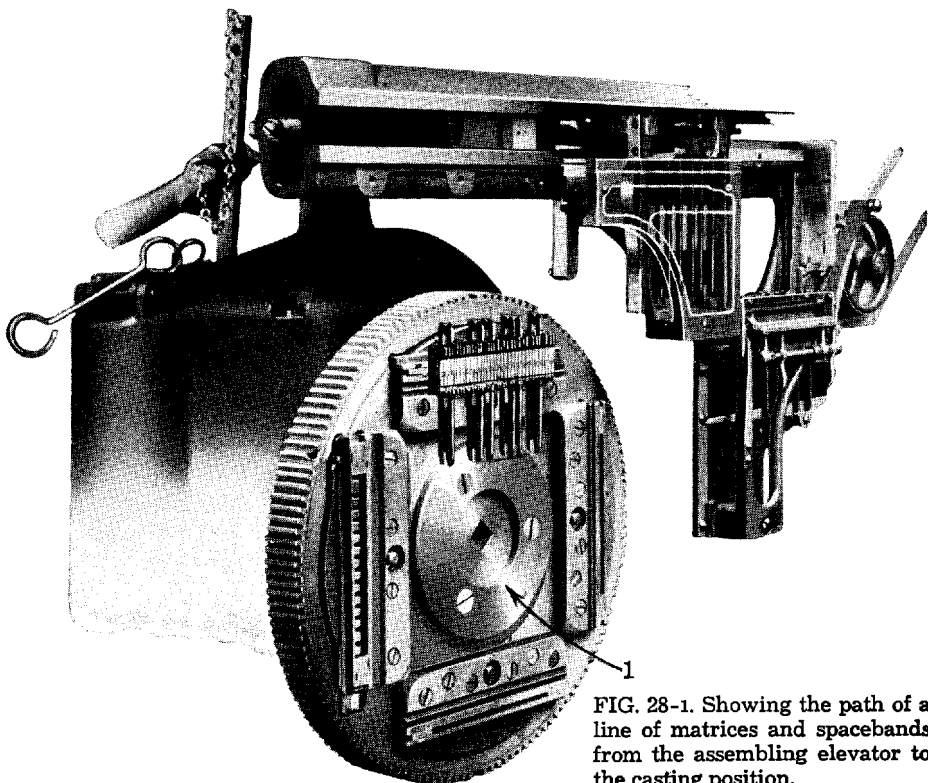
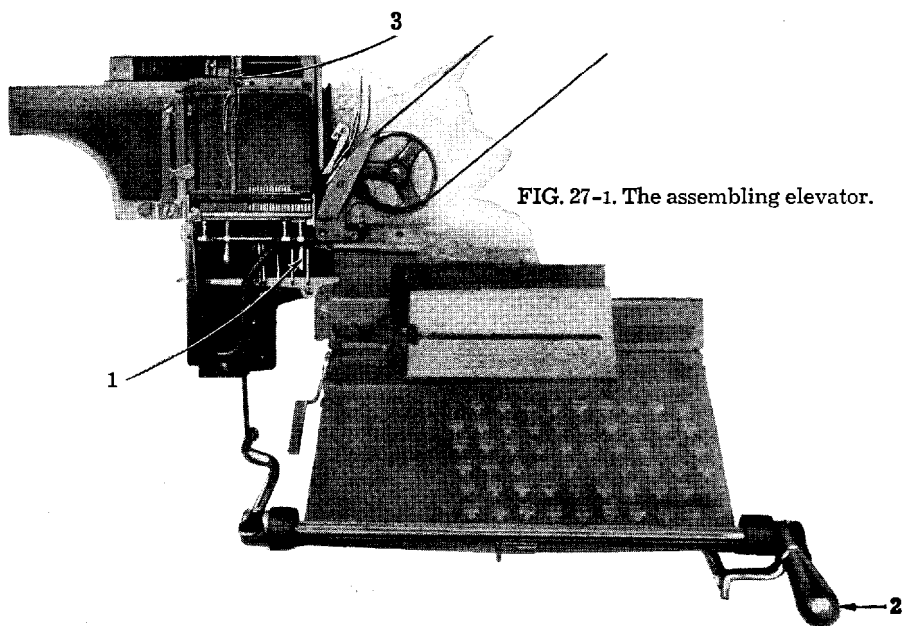

FIG. 26-1. This view indicates aligning and casting level. Assembled in this manner top characters of the lower matrices and bottom characters of the raised matrices will be cast in the same line.





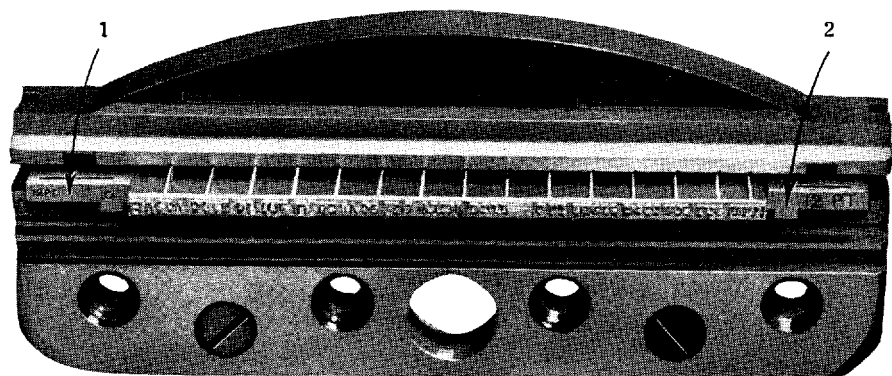

FIG. 29-1. The length of the mold slot (and the length of the slug) is determined by the length of the piece of metal, or liner, 1. If the point size of slug is to be changed liners 1 and 2 are removed and liners of different thickness inserted (Fig. 34-1).

Where the slug is cast

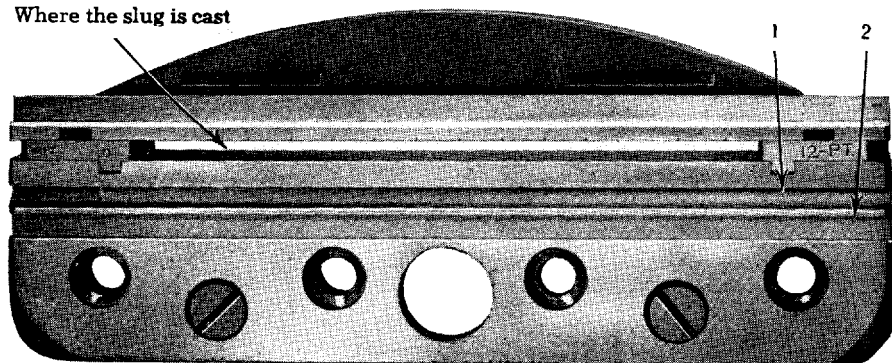

FIG. 30-1. Note the upper and lower rails (indicated by arrows 1 and 2 at the right) against which the matrices align to cast in the regular or auxiliary position as predetermined in the assembling elevator.

do double duty. For instance there may be a roman letter "k" and an italic letter "k" on the same matrix. (See Fig. 25-1.)

This doubles the capacity of the magazine, which holds the matrices, and doubles the range of the keyboard.

To get either a roman or an italic character, the operator presses the corresponding key on his keyboard. The matrix drops into the frame in which the line of matrices and spacebands is gathered—known as the assembling elevator. (This is called an elevator because it not only gathers the line of matrices and spacebands, but, after they are assembled, elevates them about five inches, to a position from which they are transferred to the "casting" position.)

The operator can decide whether roman or italic is to be cast. (See Fig. 26-1.)

In the assembling elevator and throughout the entire delivery mechanism there are two rails, or tracks, on which the matrices rest and ride. If matrices are assembled on the top rail, characters punched in the lower position will be cast: if assembled on the bottom rail roman characters will be cast.

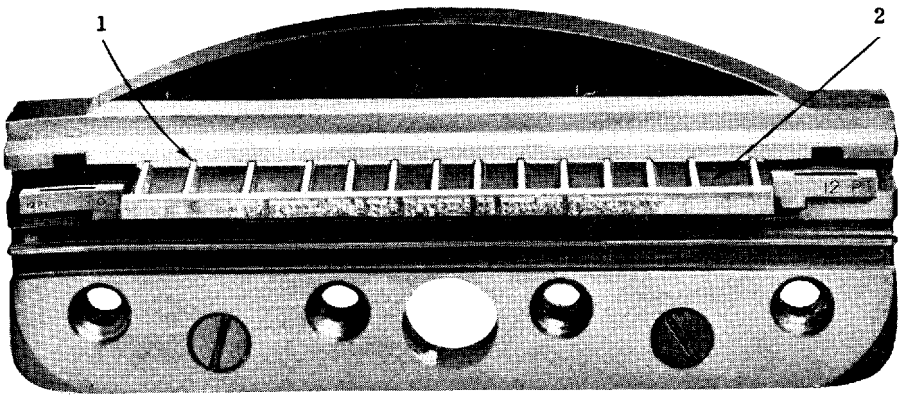

FIG. 31-1. Recessed mold.

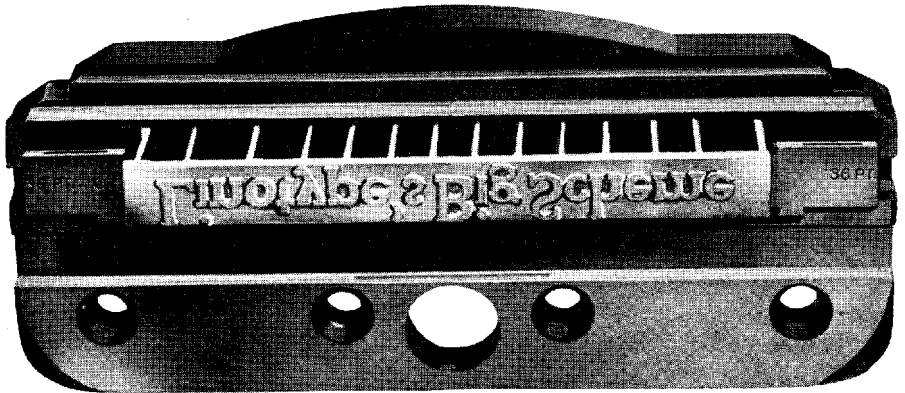

FIG. 32-1. Display mold.

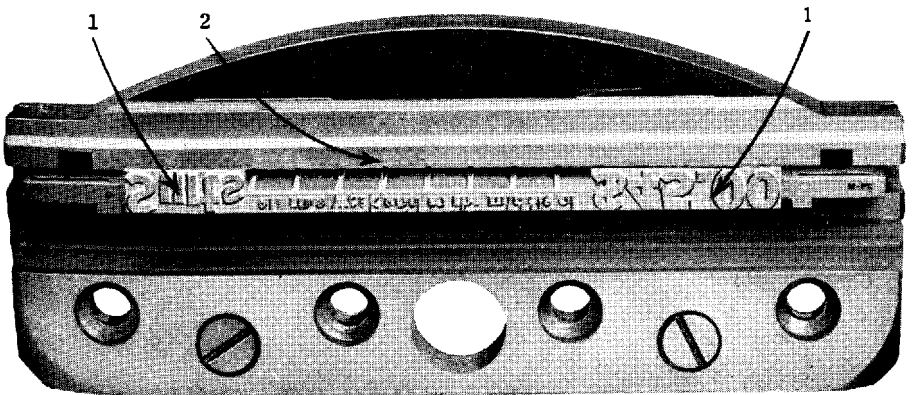

FIG. 33-1. Advertising figure mold.

Besides italic, the two-letter matrices are used to carry bold face, small caps, and in some cases a second type-face.

Single characters, words, sections of lines or entire lines may be set in bold face, in roman, italic or small caps, at will and without loss of time.

The operator will determine which rail the matrix shall assemble on, by pressing in or pulling out on the small lever 2, Fig. 26-1. This lever controls the first half-inch of the top rail—throws it in or out. If it is in, the matrices are all assembled on the top rail (this is called the *auxiliary* position). If it is out, the matrices are all assembled on the bottom rail (this is called the *regular* position).

If the operator leaves the first half inch of the top rail in, all of the matrices will assemble on the top rail, and be cast in the auxiliary position. If he leaves this first half inch of the top rail out, all of the matrices will then assemble on the bottom rail and be cast in the regular position.

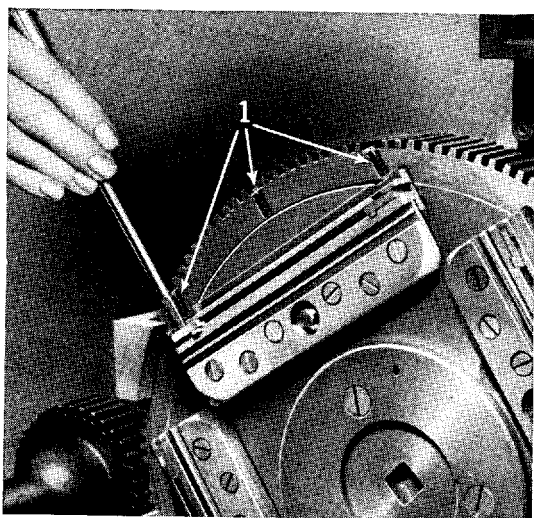

FIG. 34-1. View of method of changing mold liners.

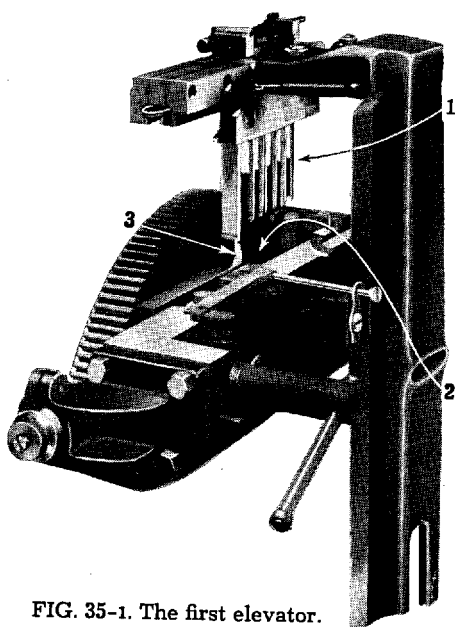

FIG. 35-1. The first elevator.

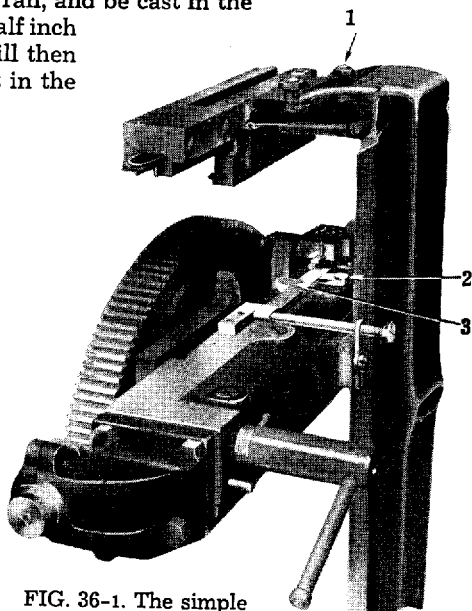

FIG. 36-1. The simple two-letter attachment. Adjusting screw 1 comes down on point 2, when this attachment is in use, and prevents the first elevator from descending farther. The matrices are thus held higher than usual, and the cast is made from their auxiliary characters.

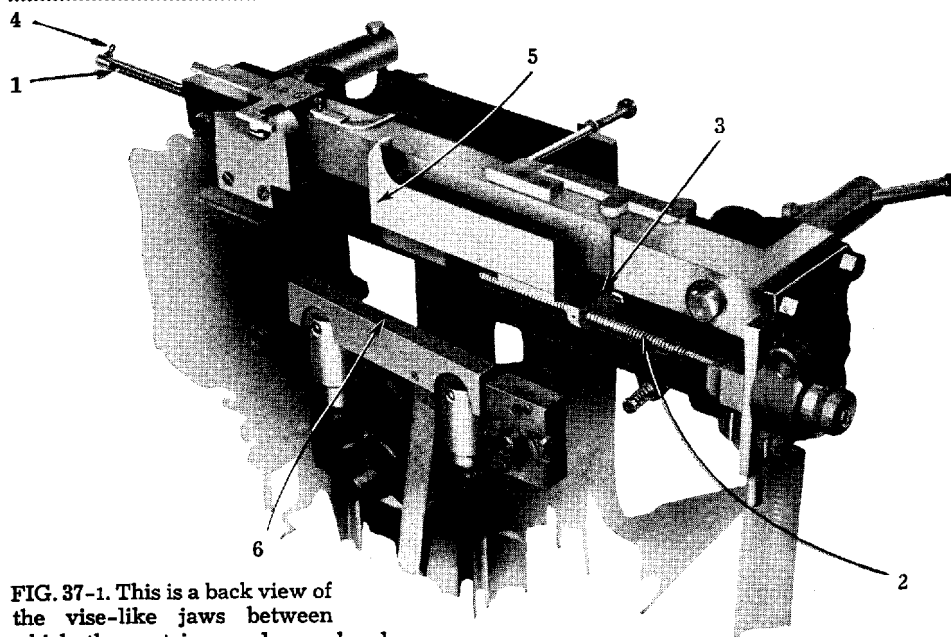

FIG. 37-1. This is a back view of the vise-like jaws between which the matrices and spacebands are held while they are in the casting position in front of the mold. The mold disk, of course, is not shown here as it would make this view impossible.

The assembling elevator, Fig. 27-1, is, in simplest terms, a device which catches and holds the assembling matrices and spacebands until there is a line full of them. It serves much the same purpose as a printer's stick. When it is full the operator depresses the lever 2 at the right of the keyboard, which lifts the assembling elevator about five inches, from which position the delivery slide 3 automatically carries the matrices and spacebands to the left into a jaw also having two rails which lowers them into position in front of the mold. This jaw is shown in Fig. 35-1 and in a different position in Fig. 38-1.

The matrices and spacebands face a mold in the disk and form the front of a slot into which molten metal is forced. There are four such molds on the large revolving disk (the mold disk).

It takes only an instant for the metal to be forced into the slot-like mold and into the characters in the matrices. The metal quickly cools, forming the Linotype slug with its clean new type.

The molds are adjustable to cast lines of varying length and thickness. These molds are removable and there are several different kinds, a number of which are shown in illustrations Fig. 29 to 33-1.

The center of the mold disk 1, shown in Fig. 28-1, page 17, is filled with circulating water for cooling—an exclusive Linotype feature, which permits greater speed when casting large slugs, guards against over-heating of mold and disk, and insures greater accuracy of product.

Fig. 29-1 shows a Universal Adjustable Mold removed from the disk with the main parts separated. It is adjustable as to the length and thickness of the slug it will cast. By removing the two pieces of metal (liners) 1 and 2, and substituting them with others, slugs of any length from 5 to 30 picas and from 5 up to 14 point in body may be cast.

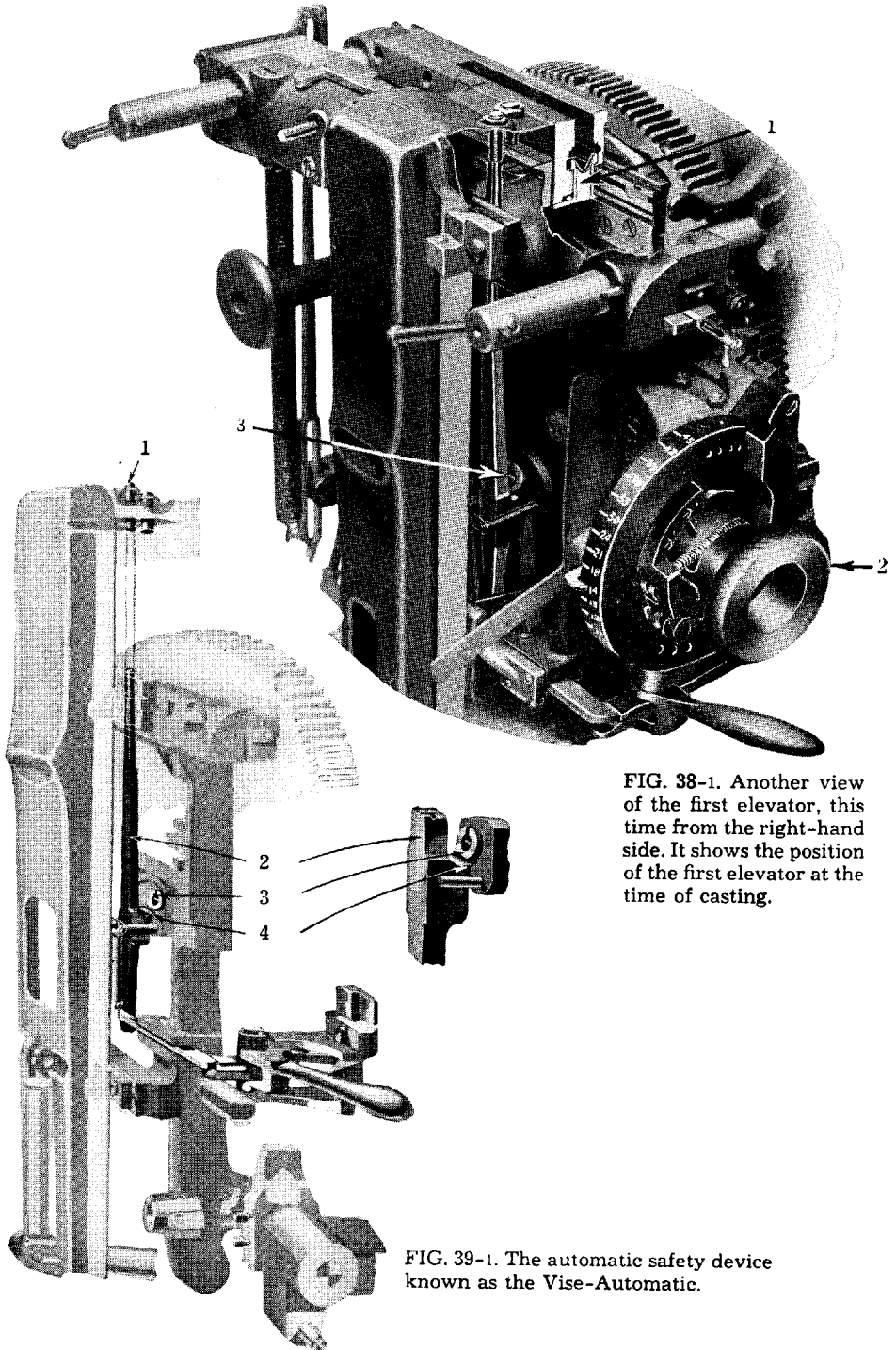

FIG. 38-1. Another view of the first elevator, this time from the right-hand side. It shows the position of the first elevator at the time of casting.

FIG. 39-1. The automatic safety device known as the Vise-Automatic.

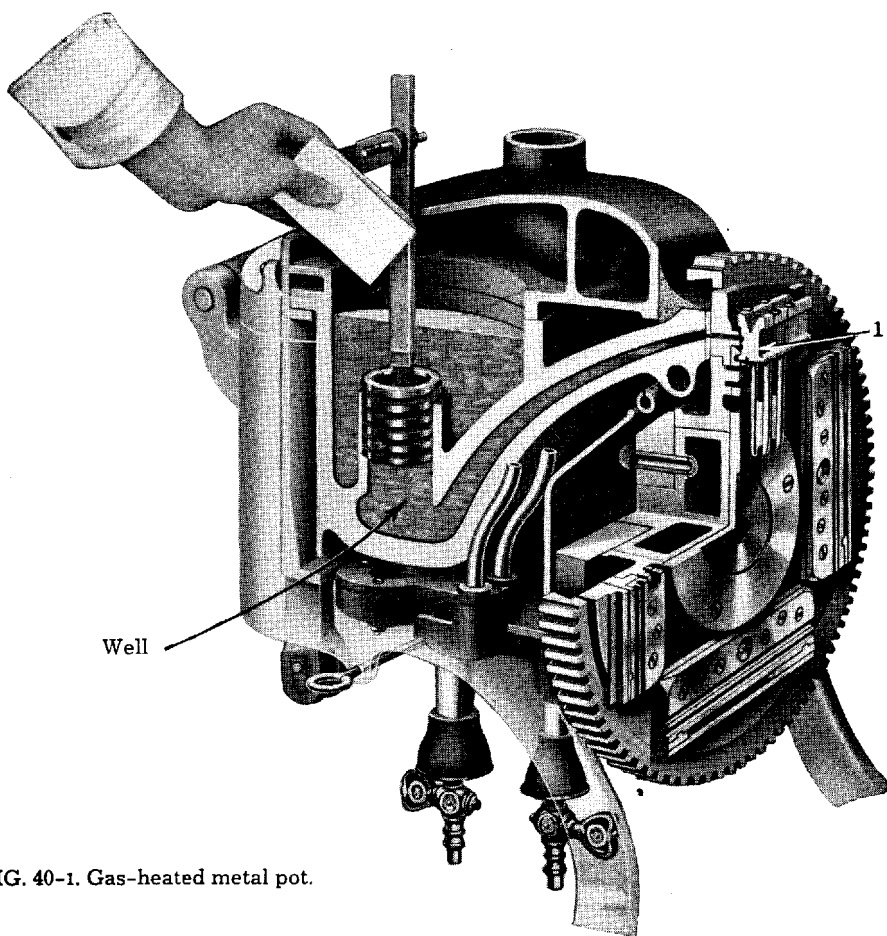

FIG. 40-1. Gas-heated metal pot.

Not more than one or two minutes are required to adjust the mold for any body and measure described. Since there are places for four molds in the disk, any one of which may be used at will, the necessity for changing liners arises only infrequently. Disks to accommodate six molds are provided for special needs.

In order to lead matter it is only necessary to use liners thicker than the face used. For instance, if leaded 6 point is required, 8 point liners may be inserted in the mold and 2 point leading will result.

It is not necessary for the thicker Linotype slugs to be solid metal. So, for the sake of light weight and quick cooling, provision is made for casting slugs with cavities, or recesses.

The Recessed Mold, shown in Fig. 31-1, is provided for slugs from 10 to 14 point. Note that the lower surface of the top section has rectangular projections and grooves 1. The molten metal is forced into these grooves, and forms supporting ribs beneath the "type" face. The rectangles form the recesses 2. In this manner, the weight of the slug is reduced about one-third.

The ribs give more than sufficient support to the face for normal stereotyping, electrotyping or direct printing.

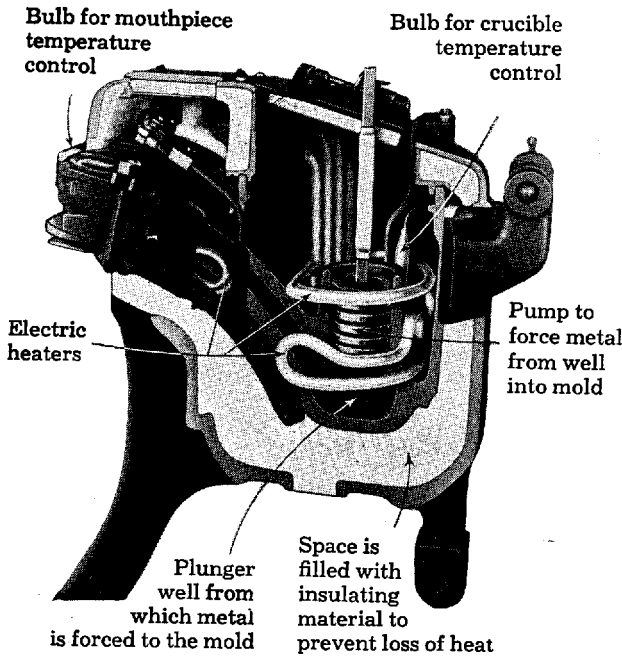

FIG. 41-1. Cross section of Linotype electric pot.

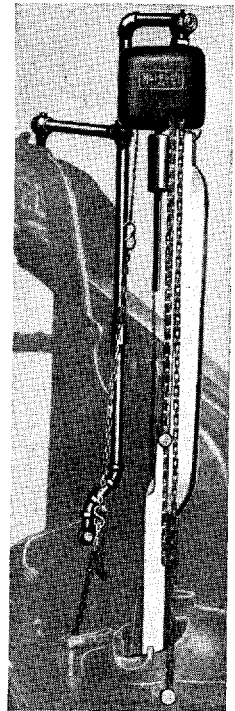

FIG. 42-1. Gas pot with metal feeder.

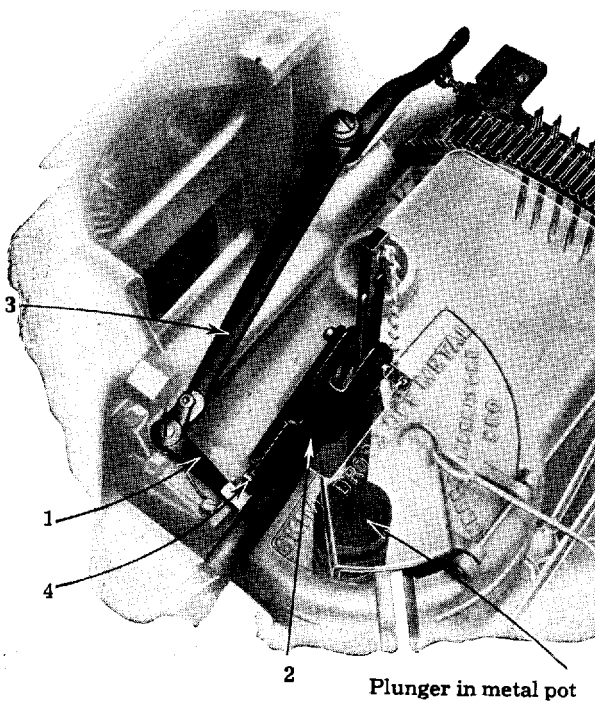

FIG. 43-1. The pot pump stop. Arm 1, which locks the pump lever 2, does not move back and allow pump lever to descend unless the front part of operating lever 3 is pressed to the right by a completely filled line of matrices and spacebands. If arm 1 has not moved back, catch block 4 on pump lever comes in contact with arm 1 and keeps the pump lever from descending.

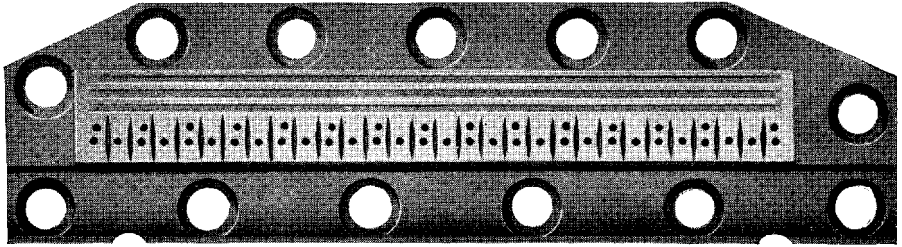

FIG. 44-1. Linotype mouthpiece.

Extra large slugs from 18 to 45 point, for display composition or head-letter composition, are cast in a Display Mold, Fig. 32-1, which forms greater recesses in the slug. The large projecting rectangles on the lower surface of the upper section of the mold, mean just that much metal saved in casting. The metal flows into the grooves between the rectangles and the supporting ribs in the slug result.

Lighter slugs cool more quickly and permit speedier composition. And lighter slugs are, of course, more conveniently handled. Furthermore, if slugs are to be stored, less metal is tied up.

Slugs with overhanging characters are cast in the Advertising-Figure Mold, shown in Fig. 33-1. The "overhanging" portions 1, are cast against an extra-thick lip 2. The combination of such slugs is illustrated in Fig. 14-1.

This mold provides the greatest possible range of type sizes and thus enables the operator to compose advertising and similar copy with a minimum of time and effort.

It is not necessary to remove the Linotype mold from the disk (and thus expose it to injury) in order to change liners for different lengths and thicknesses of slug. Nor are special tools necessary.

First loosen the three screws 1, shown in phantom in Fig. 34-1. Then, with the same screwdriver, the liners are easily slipped from between the cap and body of

the mold. Little notches in the tops of the liners are especially cut in order to accommodate the screwdriver. If the length only is to be changed, the right-hand liner need not be removed.

Returning now to the progress of the matrices through the machine, after the matrices and spacebands are assembled into a line in the assembling elevator and lifted, they are carried to the left into the first elevator and arrive in the position 1, shown in Fig. 35-1.

This first elevator lowers them into the space between a pair of vise-like jaws into the position 2, which they will occupy while the Linotype slug is being cast from them. The left-hand vise jaw 3, is adjustable to

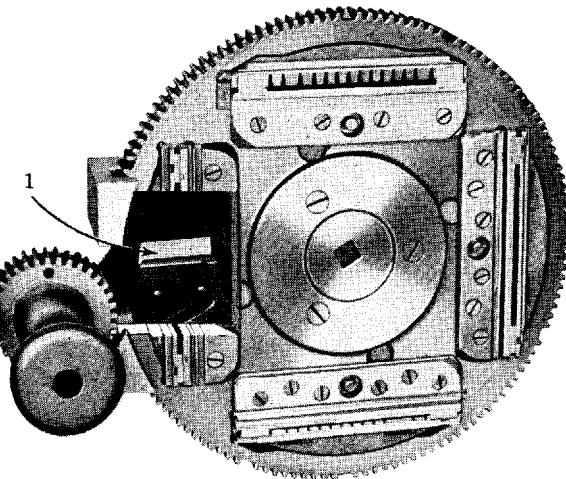

FIG. 45-1. View of mold disk with section removed to show back knife.



After the slug is cast mold disk makes three-quarters of a revolution to ejecting position as shown.

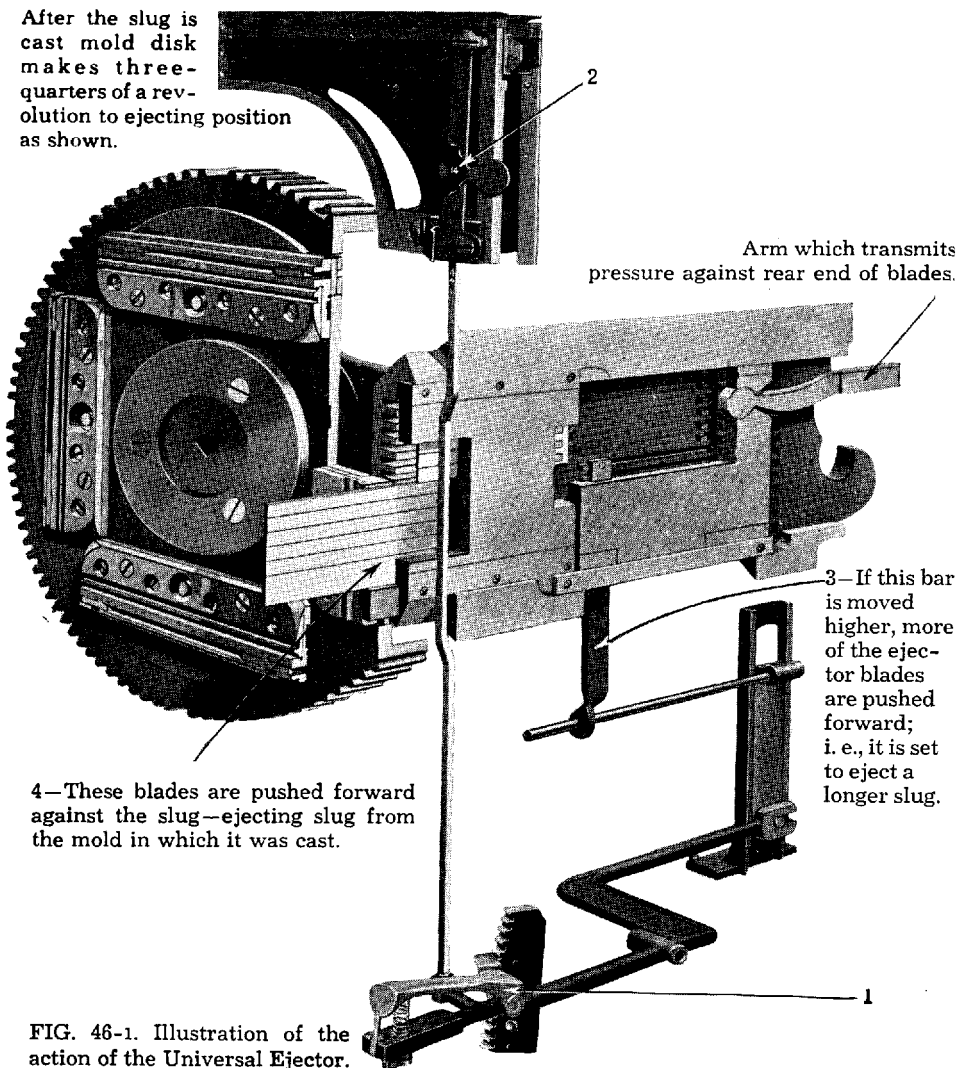

FIG. 46-1. Illustration of the action of the Universal Ejector.

vary the length of the line of type on the slug in accordance with requirements.

After the casting operation is completed, the first elevator lifts the matrices and spacebands to a position higher than that shown in Fig. 35-1, from which position the matrices are transferred to the distributing mechanism and the spacebands to the spaceband box. (See Fig. 50-1.)

Fig. 36-1 shows the Linotype attachment which enables the operator to cast a slug from matrices in the auxiliary position without bothering to assemble the matrices in the auxiliary position in the assembling elevator.

For instance, when the operator wishes to cast several lines of italics from matrices on which there are both italic and roman characters, he simply sets the matrices in the normal way, then flips the filling-piece 3 over to the right. It

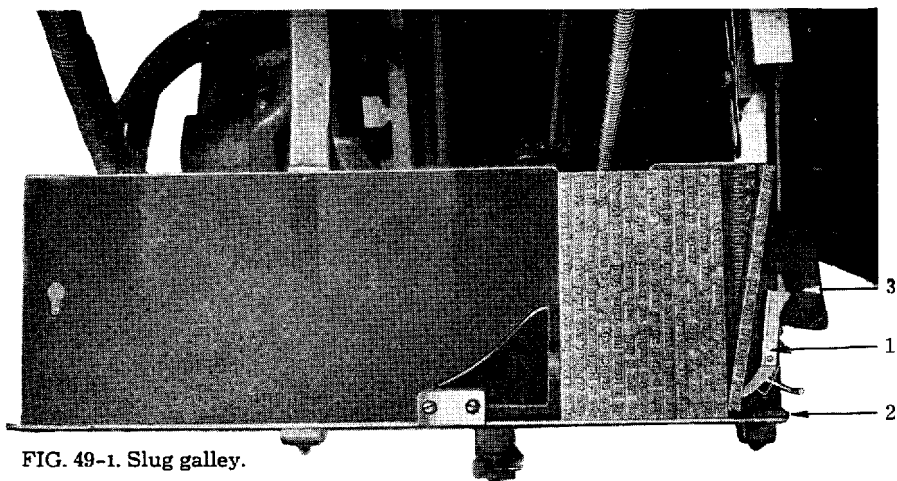
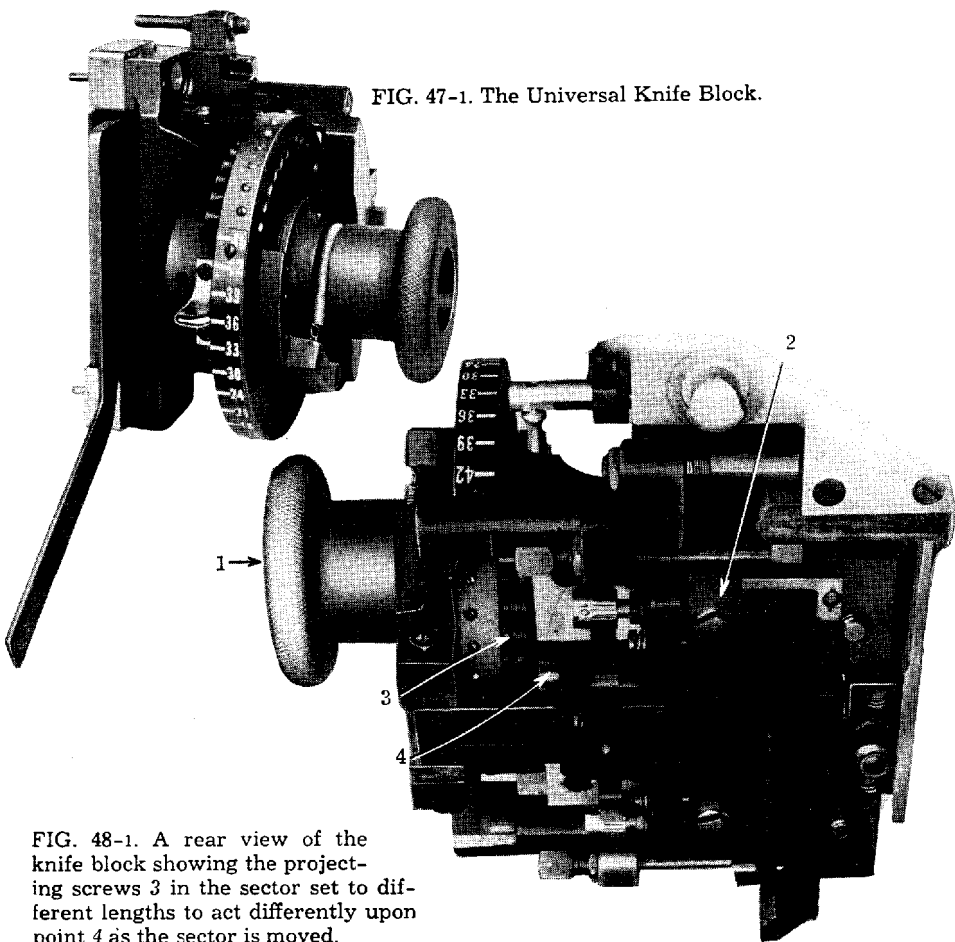

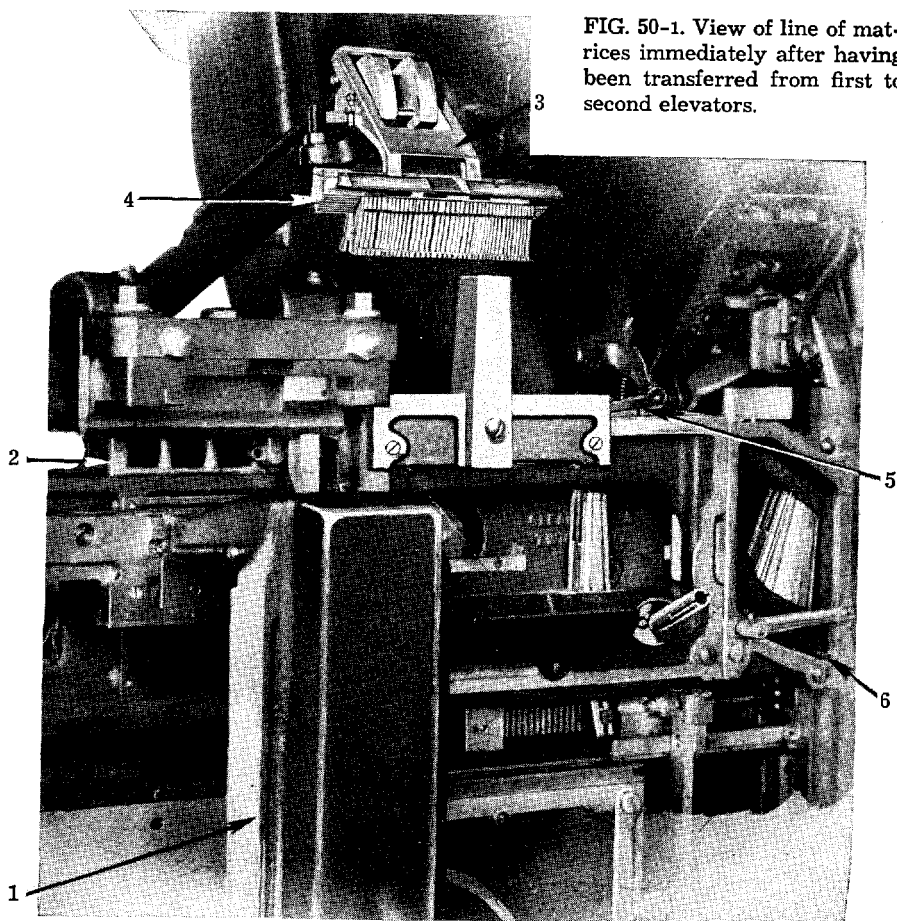

FIG. 50-1. View of line of matrices immediately after having been transferred from first to second elevators.



FIG. 51-1.  
The second elevator bar.

keeps the first elevator from descending full distance, all of the lines being cast in the auxiliary position. This device is called the Simple Two-Letter Attachment.

The vise jaws, Fig. 37-1, have to vary in separation to accommodate lines of different lengths.

A method is provided for easy changing of the distance between them. The operator grasps the adjusting bar handle 4, and with a simple upward movement disengages the adjusting rod grooves 2 from locking block recesses 3. The rod 1 is then moved to the left or right to the desired measure, when a downward movement of the handle 4 locks the adjusting rod

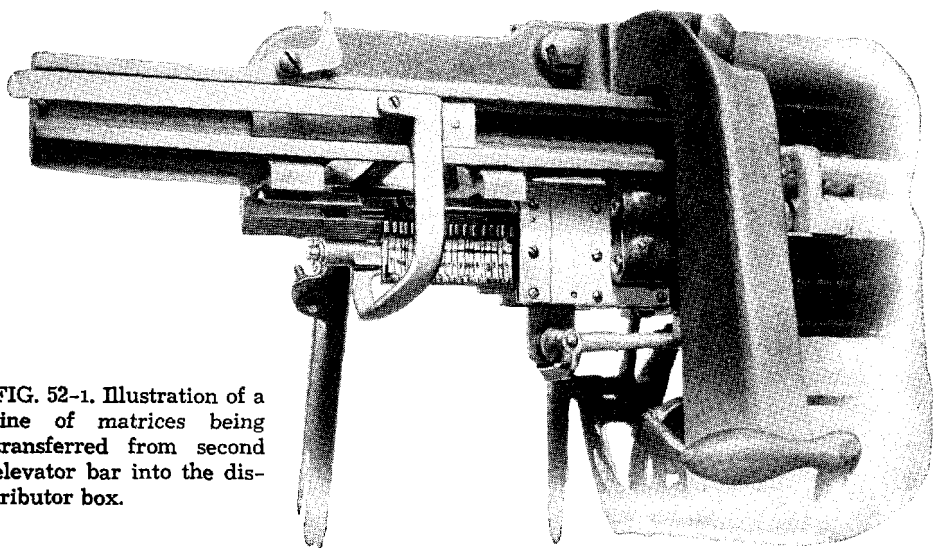

FIG. 52-1. Illustration of a line of matrices being transferred from second elevator bar into the distributor box.

grooves in the locking block recesses 3. The adjusting rod 2, on which the vise jaw 5 banks, is on a dead center line of both right- and left-hand jaws, which insures the left-hand vise jaw facing up squarely with the line of matrices.

This convenience, known as the Quick-Change Left-Hand Vise-Jaw Attachment, gives positive and accurate control of the jaw.

Directly below the jaw is the justification bar 6, which rises against the lower ends of the spacebands and wedges them, so that the word-spacing is spread until the line is full width.

The view as shown at 1 on Fig. 38-1 is partly in section and illustrates the relationship of the matrices to the mold.

The vise-automatic stop, shown at 3, is illustrated in Fig. 39-1 following.

The justification bar, which wedges the spacebands, is illustrated in Fig. 37-1.

The Universal Knife Block is shown in Figs. 47 and 48-1.

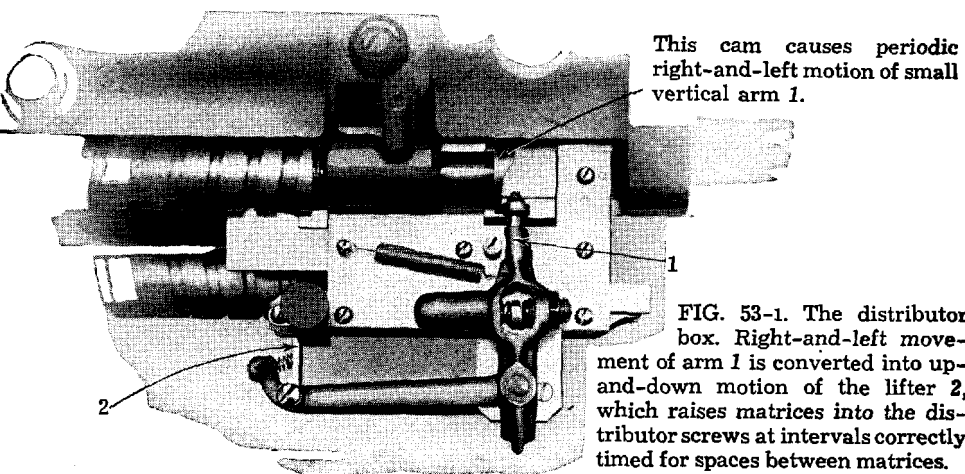

This cam causes periodic right-and-left motion of small vertical arm 1.

FIG. 53-1. The distributor box. Right-and-left movement of arm 1 is converted into up-and-down motion of the lifter 2, which raises matrices into the distributor screws at intervals correctly timed for spaces between matrices.

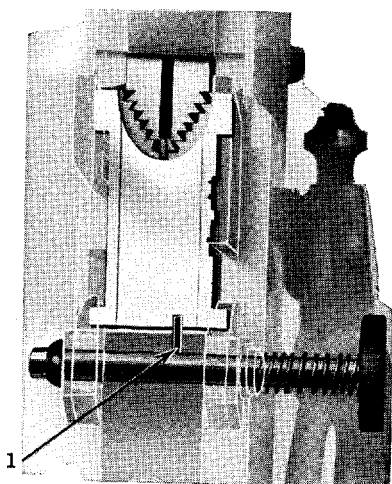

FIG. 54-1. Automatic font distinguisher.

When the machine is operating under normal conditions adjusting screw 1, Fig. 39-1, comes in contact with the end of automatic rod 2, pushing it down far enough so that plunger 3 can be pushed over a pawl 4 by the action of mold disk coming forward.

If the operator happens to overset a line and the elevator does not descend far enough, the plunger 3 comes in contact with the small pawl 4, which is held up by a spring, and the lower end of rod 2 pushes against a connecting lever which shuts off the casting mechanism and prevents the line from casting.

The metal from which Linotype slugs are cast can be melted and kept heated to the proper temperature by gas, electricity, gasoline or kerosene.

An illustration in cross section of the gas-heated metal pot is shown in Fig. 40-1. The electric pot is shown in Fig. 41-1.

When a line of matrices and spacebands has taken its place in front of the mold disk as shown at 1 in Fig. 40-1, the metal pot advances slightly until it touches the back of the mold which is in use, then the plunger in the center well is forced down, and the mold and the indented characters in the matrices which close the front of the mold slot are filled with molten metal. The metal solidifies—resulting in the Linotype slug.

To keep the metal at an even heat, hour in and hour out, all day, a simple thermostatic governor is provided. Linotype pots are completely cased in by a non-conductor to keep the heat in and to protect the metal.

One important feature of the Linotype pot is the method by which metal is drawn from the crucible proper into the center well. When the plunger rises, the molten metal is drawn through two holes in the sides of the well. The surface of the molten metal is hardly disturbed by this process—it remains practically intact, and there is a minimum of oxidation of the elements of the metal, especially of the tin, the most expensive of these elements and the most easily oxidized. Furthermore, this method insures that only clean metal is drawn into the well.

Another distinctive feature of Linotype metal pots is their exclusive mouth-piece, shown in Fig. 44-1.

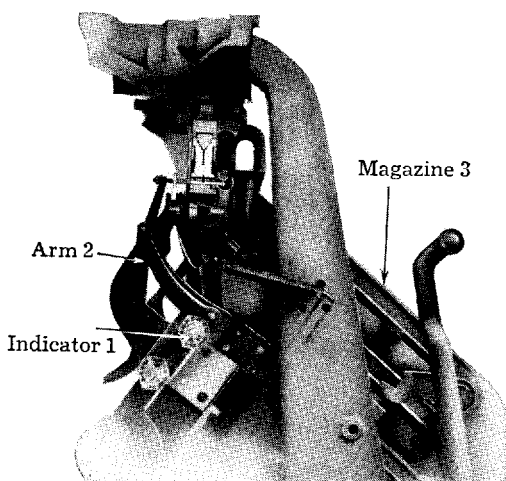
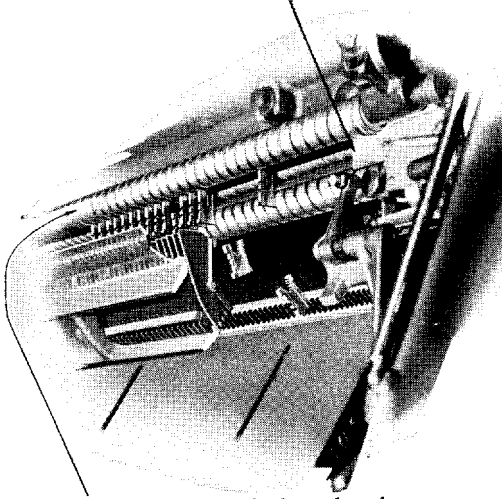

FIG. 55-1. View of font distinguisher shows how the position of the arm 2 determines the front-to-back position of the vertical knife-like projection in the bottom of the distributor box.

Matrices leave distributor box at this point and are moved to the left by three conveyor screws.



Each matrix is moved along by these screws to a point at which the corresponding teeth on the bar are cut away and cease to support it. It drops at this point into the correct channel of the magazine below.

FIG. 56-1. Illustration of matrices being distributed.

Fig. 41-1 is a cross-section view of the Linotype Electric Metal-Melting Pot equipped with Lino-Therm heaters and Micro-Therm control of temperatures.

Linotype melting pots hold 44 pounds of metal. As molten metal is used for casting slugs, bars of metal may be fed into the pot by means of an automatic feeder as shown in Fig. 42-1, or smaller pigs of metal may be fed into the metal pot by hand.

The electric pot has many advantages over the gas pot. It has no flame and no products of combustion. Furthermore, it is possible with the electric pot to regulate the temperature much more closely. Close regulation of the temperature of the molten metal greatly improves casting conditions and the resultant slugs.

Electric heaters are immersed in the metal, other heaters snugly contact the throat and mouth of the crucible—exactly where heat is

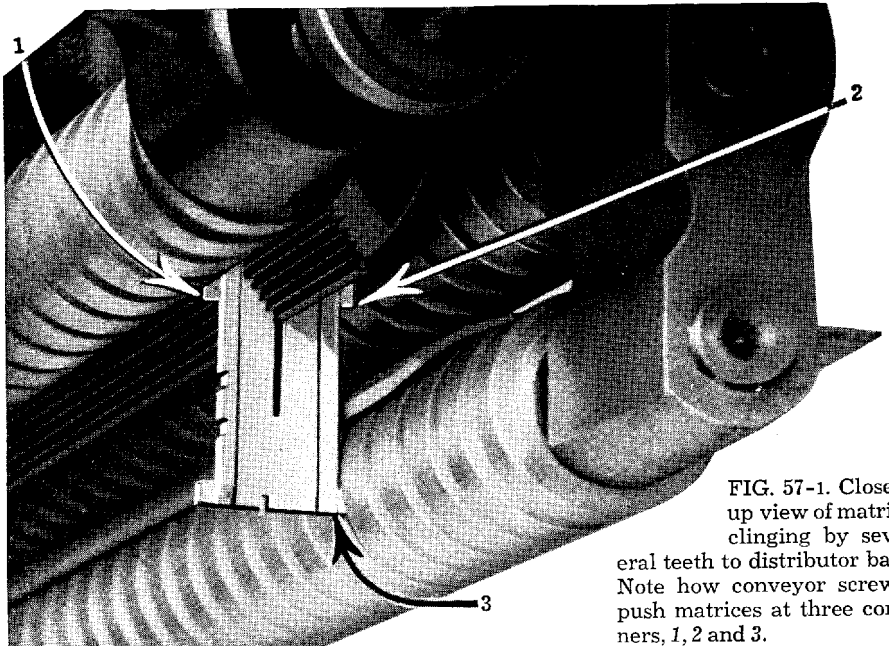

FIG. 57-1. Close-up view of matrix clinging by several teeth to distributor bar. Note how conveyor screws push matrices at three corners, 1, 2 and 3.

required and where the application of heat is of greatest efficiency.

Two automatic controls govern the temperature of the molten metal. One regulates the temperature of metal in the crucible; the other regulates the temperature at the mouthpiece.

A time-clock attachment may be had which will start the heaters at a certain time in the morning so that the metal will be ready for casting when the operator reports for the day's work.

Fig. 43-1 illustrates another example of how the Linotype is made "better than human." If the operator does not set a line of matrices and spacebands full enough, there is, of course, an uncovered section of the mouth of the mold through which molten metal may escape. The device is designed to prevent this.

The right-hand vise-jaw has a little "play." Unless the line of matrices and spacebands is full enough to move the right-hand jaw to its stop, it will not operate the arm which locks the pump lever and will not permit the plunger to descend and cast the slug.

The mouthpiece of a Linotype metal pot can be taken off by removing a few screws. The use of wedges, with resulting leakage and possible damage to the mouth of the pot, is obviated.

This mouthpiece serves all thicknesses of slug, either text or display.

As the mold disk, Fig. 45-1, revolves from its casting position to the position for ejection, the mold containing the slug passes the back knife 1 which trims the bottom of the slug to make it type high.

There must be some way to "eject" the slug from the mold after it is cast.

Obviously, since the slug is apt to be of any length up to 30 picas, some method must be established for varying the length of the blade by which the slug is pushed forward out of the mold. Linotype's ejector is *universal* for all thicknesses and lengths of slugs. Fig. 46-1 illustrates the inside structure of the Linotype Universal Ejector.

The old-fashioned way was to provide the operator with an assortment of blades of different lengths, so that when he desired to change ejectors, he could do so only with the expenditure of considerable time.

Now, all that the operator has to do is to move a handle and watch the indicator 2. By moving the handle 1 up or down, he moves indicator 2 up or down, and also bar 3. The higher bar 3 is, the more blades are pushed forward, and the longer the slug that may be ejected. The blades 4 move between plates which brace them firmly on both sides, thus giving them rigidity and preventing bending.

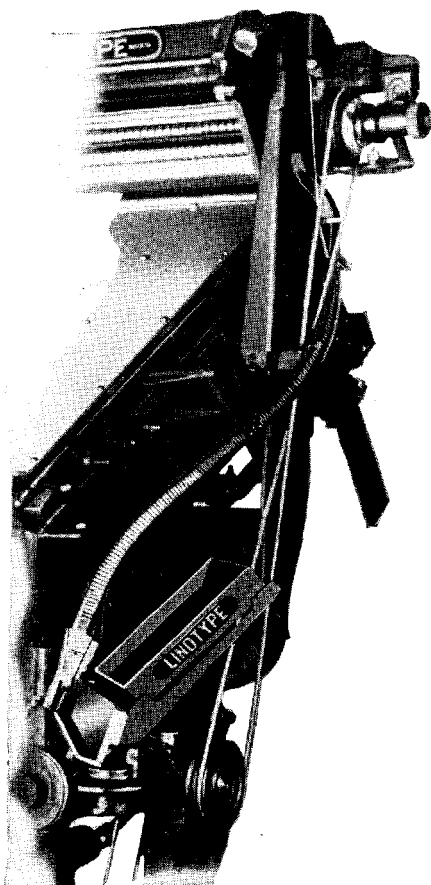

FIG. 58-1. View of the sorts stacker for pi matrices.

In addition to ejecting the slug from its mold, these blades also push the slug through a pair of shaving knives which trim it true on the sides.

When the newly cast slug comes from the mold, it may have a few small projections, so to make sure that it will be absolutely smooth and true on the sides, it is passed between two knife-edges which trim it clean and parallel. This movement is accomplished by the ejector blades on the same stroke with which the slug is forced from the mold.

After this trimming, the slug slides into the galley on the front of the machine. Then the slug is finished and ready for use.

Now, since the Linotype casts slugs from 5 to 45 points in thickness, there must be some way to vary the distance between the trimming knives.

This adjustment is easily made on the Linotype by the Universal Knife Block pictured in Figs. 47 and 48-1. A simple turn of the knob 1 causes the right-hand knife 2 to move from the left to right or back.

The screws 3 in the sector (20 in all) are independently adjustable. For example, the screw which determines the knife trim at 8 point can be "let out" a bit so that the 8-point slugs will be trimmed a trifle "full," or turned in to result in a "close" trim. This is sometimes desirable for effects in spacing between lines.

The Linotype galley shown in Fig. 49-1, in which the work of the Linotype is deposited, is inclined to a degree best adapted to permit the greatest speed and efficiency in the delivery of slugs regardless of the length and body size.

The descent of the slug is arrested by spring tension hook 1, allowing it to fall gradually on leather buffer 2, which, in turn, prevents damage or burring at the end of slug.

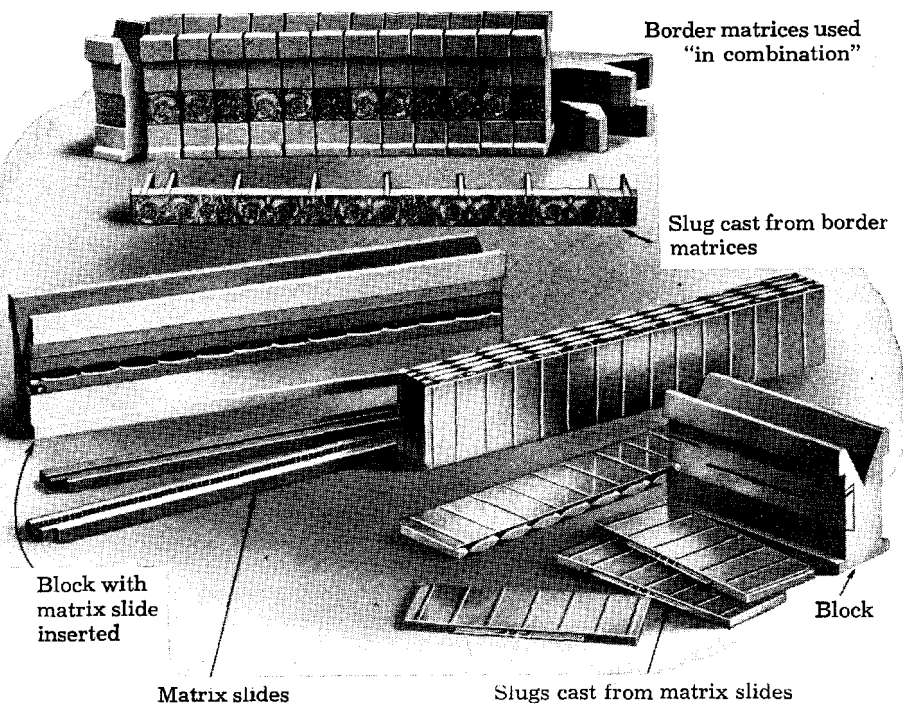

FIG. 59-1. Border matrices, matrix slides, and slugs cast from them.





FIG. 60-1. Several styles of racks are available, for storage of various combinations of extra magazines, either full-length, split or auxiliary.

The slug lever, 3, automatically advances the slug on the galley, while the pressure of spring tension hook 1 prevents any tendency of the slug to fall backward and thus interfere with delivery of the next slug.

The matrices have done their work and are now on their way home to the magazine, as shown in Fig. 50-1. The first elevator 1 has lifted them up from the casting position, the slide 2 has pushed the matrices to the right onto the second elevator bar, and the second elevator 3 has now started to lift them up toward the top of the magazine into the channels of which they will be dropped by the ingenious distributing mechanism.

The second elevator has a V-shaped bar 4, with teeth on it which engage the teeth of the matrices which are held there until they are transferred from the second elevator into the distributor box.

Since the spacebands have no such teeth, they are left on a track and a metal finger 5 engages their ears and pulls them into the spaceband box 6 where they are ready to be used again.

Fig. 51-1 shows the "hand" on the end of the long arm of the second elevator. Its most important part is the toothed V bar on which the matrix teeth engage.

This hand has to have great flexibility. When down, it must fit into an exact line with the first elevator jaw so that the matrices will slide accurately onto the V bar. Their teeth align with the teeth of the bar.

When up, it must fit into an exact line with the V bar of the distributor box, shown in Fig. 52-1, so that the matrices can be moved from one V bar to the other.

After the second elevator carries the matrices up they are pushed into this small box, known as the distributor box and shown in Fig. 53-1.

At the left end of this box is a lifter which rises at regular, evenly timed intervals. When this lifter rises it lifts the matrices one at a time to be carried onto the long distributor bar by the screws of the distributing mechanism which carries them home to their proper channels of the magazine.

This lifter is so timed that it keeps the matrices far enough apart to prevent them from interfering with each other as they drop into their respective channels.

Fig. 54-1 shows an arrangement (see Fig. 55-1 also) by which the machine automatically distinguishes between the different point sizes. It can be easily set for the sizes required, so as to admit matrices of one size into the first magazine, of another size into the second magazine, etc.

In the bottom of the distributor box there is a short knife-like vertical projection 1, which can be moved from front to back. Unless the notches in the bottom of the matrices match the projection, the matrices cannot pass through the distributor box, and the distributing mechanism is stopped. This prevents 8 point matrices, for instance, from being distributed into a magazine of 6 point matrices.

As the magazines are raised or lowered, arm 2, as shown in Fig. 55-1, rests on one of the hexagonal indicators. If, for instance, arm 2 is resting on hexagon 1, the point-size of matrices admitted into the magazine 3 will be determined. By turning hexagon 3, the operator can decide the point-size of matrices to be admitted to magazine 3. There is one hexagon for each magazine. They are pivoted off-center, so that each of their six sides affects 2 in a different manner.

The teeth in the V-shaped end of the matrices are arranged differently for different characters, similar to the teeth on Yale keys. The various teeth combinations of matrix and bar make it possible for the matrices to find their proper magazine channels automatically.

The teeth hold the matrices suspended from the teeth on the distributor bar. When a matrix arrives at a point where the distributor bar teeth which have been supporting it are cut away, it drops into the magazine channel from which it originally came. (See Fig. 56-1.)

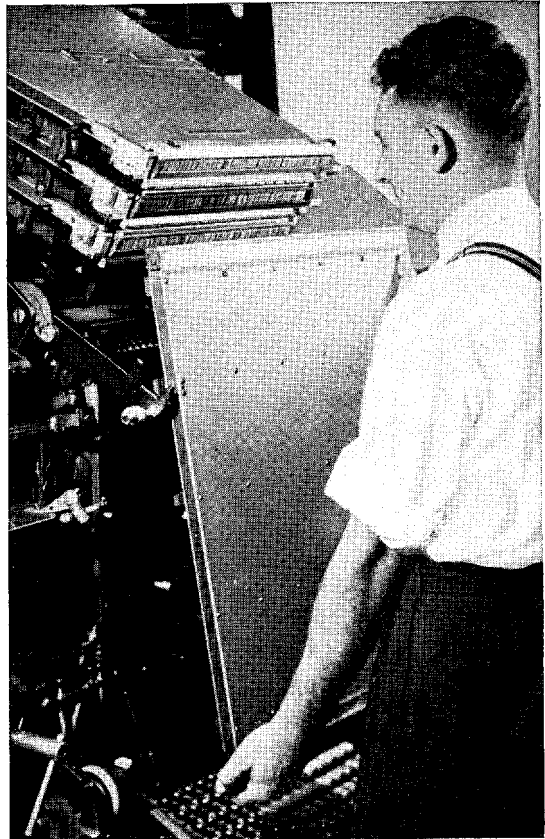

FIG. 61-1. Illustration showing method of changing magazines.

In this way the matrices are used over and over again continuously.

The conveyor screws are actuated through a clutch at the right end which automatically disengages when there is any resistance at any point along the screws. If for any reason a matrix should become "stuck" anywhere along the line, this automatic cessation of the conveyor movement prevents damage to matrices or conveyor mechanism.

If the operator wishes to use special characters or sorts, such as algebraic figures or fractions, in such small quantities as to make the use of channels in a magazine undesirable, the sorts stacker shown in the lower portion of Fig. 58-1 may be used for those "seldom-used" characters.

Such sorts are fitted with a tooth combination which causes them to ride the entire length of the distributor bar and drop off at the end of it—into the flexible metal tube at the right of the machine, shown in Fig. 58-1.

After the matrices pass through the tube they are stacked by means of a belt-driven elliptical star wheel, onto an inclined shelf. A sliding stop holds the matrices erect, in position to be easily available for further use.

In casting rules, borders and other ornamental and decorative material such as that shown in Fig. 59-1, it is possible to use, instead of a number of matrices, a matrix slide block into which has been slipped a matrix slide containing the desired rule, border, or decorative design.

One matrix slide block may be used for any number of different matrix slides, and expenditure thus reduced. Slides may be had in a great variety of lengths and point-sizes; blocks, in lengths as desired.

After the slide has been inserted in the block, the block is placed in casting position in the first elevator jaw. As many slugs as desired can be produced from one slide by recasting.

Many border designs can be easily and quickly cast from Linotype border matrices, and the matrices can be used in various combinations.

Substitution of either full-length, three-quarter length or split magazines is accomplished with a minimum of effort. All changes are made from the front of the machine, eliminating lost time and motion.

Magazine additions, as indicated in Fig. 62-1, can be made in the composing room by any operator. No dismantling or discarding of old parts is necessary, nor is the assistance of an expert machinist required.

In this discussion, "The Big Scheme of Simple Operation" or "What The Linotype Is," no reference has been made to the many time-saving and cost-cutting features available on Linotypes.

Rather, the thought has been to confine the foregoing discourse to an explanation of the fundamentals of the Linotype.

Sales literature and chapters of Linotype Machine Principles cover fully such Linotype features as the Self-Quadder, Six-Mold Disk, Optic-Aid Front, Blue Streak Shift, Micro-Therm Heat Control, Thermo-Blo Mold Cooler, Linotype Auto Ejector, Quick-Opening Knife Block, and the many other Linotype features.

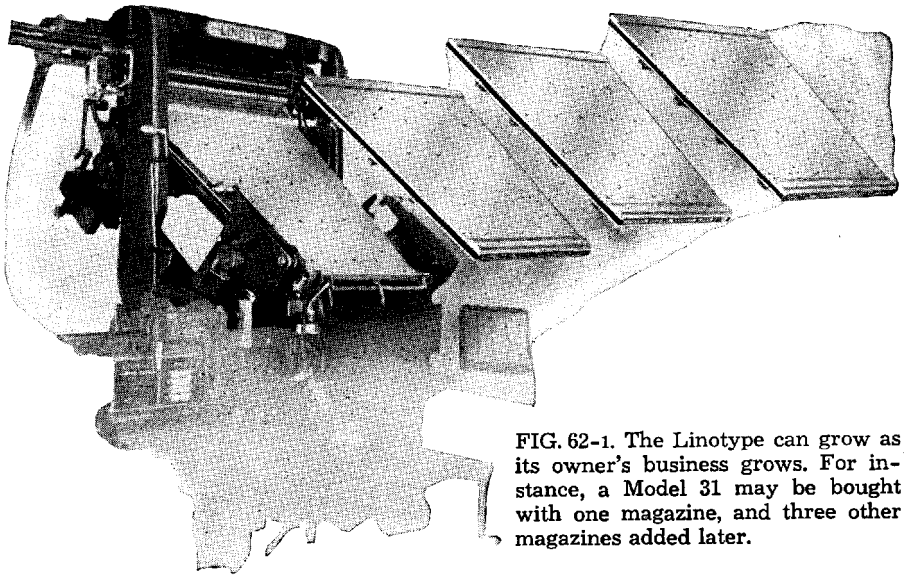

FIG. 62-1. The Linotype can grow as its owner's business grows. For instance, a Model 31 may be bought with one magazine, and three other magazines added later.

## *How the Big Scheme Fits Plant Needs*

**E**MBODYING the principles of construction and operation outlined in these pages, Linotypes are designed in several models to meet different requirements. The variations in these models are simple in principle. The fundamental classifications in Linotype machines include single distributors, plural distributors or "mixers," and super-display Linotypes.

Single distributor Linotypes compose from and distribute matrices to one magazine at a time. Such machines may carry, for convenience, as many as four main magazines and up to four auxiliary magazines.

Plural distributors are nick-named "mixers" because they compose matrices from two or more magazines simultaneously and distribute continuously to the plural assortment of magazines. Thus roman, italics, and small capitals may be mixed at will in the same line with bold face or other contrasting characters from other magazines. The procedure is continuous with automatic distribution of the lines of mixed matrices back to the proper magazines.

Super-display Linotypes are adapted to the use of extra-wide magazines, with 72 or 90 channels, whose capacity includes type sizes ranging from text matter up through full 36-point faces.

The "two-in-one" principle, applied to the foregoing classifications of Linotypes, provides for the use of 72-channel and 90-channel magazines in the same machine, with corresponding mold equipments. This facilitates the setting of text and display matter on one machine, providing for a more uniform handling of composition requirements, or (in a single machine plant) the facilities of a veritable type foundry.

The various kinds of Linotypes are available with main magazines (from one to four as desired) and with added auxiliary magazines (likewise from one to

four). Within their classifications of channel capacities and widths these magazines are interchangeable on all current models of Linotypes.

The big scheme of simple operation provides the All-Purpose Linotype for the occasional need for composition with hand-set matrices. This machine utilizes the casting principle of keyboard Linotypes, with many ingenious features for control of casting, surfacing the slug, and almost infinite variety in the product.

How to use any or all of these facilities to the utmost profitable advantage in any plant is the question which men of Linotype, the world over, are prepared to answer as veritable composing-room engineers. They, too, are part of the big scheme of simple operation.

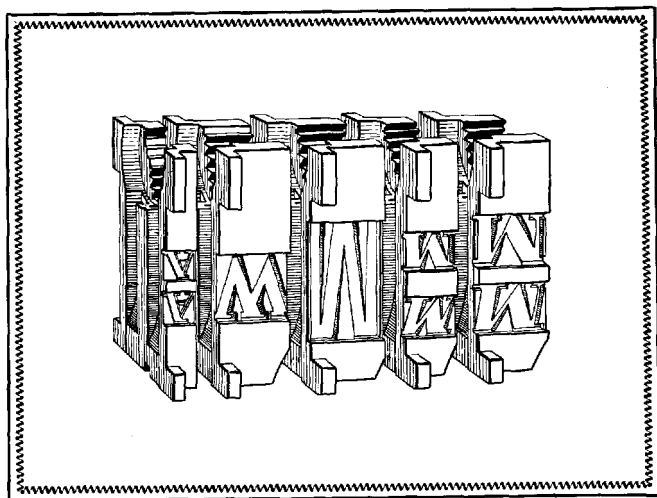

## THE CARE AND MAINTENANCE OF MATRICES

THE DICTIONARY gives as one of the definitions of the word *matrix*, "a mold in which printers' letters are cast." Immediately the matrix assumes a position of paramount importance to the printer, for he realizes that the ultimate quality of their product lies in the perfection of the type mold, or matrix.

Linotype matrix distribution is, in many ways, the most ingenious part of the whole machine. It has been achieved through the use of matrix tooth combinations, each character running in the magazine having its own particular combination. The term "tooth combination" refers to the teeth or projections on the inside of the "v" notch of the matrix. There are seven of these teeth on each side as illustrated. The various combinations of matrix and distributor bar make it possible for the matrices to find their proper magazine channels properly and automatically. In this way the matrices are used over and over. Properly cared for, they will wear indefinitely. Carelessly used, without attention being given to machine adjustments, matrices suffer unnecessarily.

The lugs, or "ears" as they are sometimes called are equally important in the proper functioning of matrices, since they

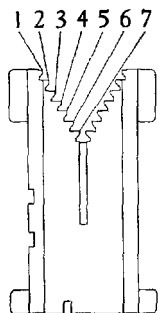

control the alignment of each letter in the lines and are the key to fine composition or just the reverse, if abused or improperly cared for.

The importance of proper matrix care cannot be overly stressed. There are some fundamental conditions which should be kept in mind. Intelligent and frequent checkups of the matrices themselves and the mechanisms affecting their operation will contribute to continued satisfaction. On the pages that follow are some useful pointers.

### *To Safeguard Matrix Teeth*

The matrix should travel from one position or transfer point to another with a maximum of smoothness and with a minimum of friction and resultant wear. The teeth of the matrix, as well as the grooves of the second elevator and distributor box bars, and the segments of the distributor bar are necessarily interdependent and inseparable in maintaining a perfectly coordinated distributing mechanism.

The matrix tooth combination, under ordinary conditions, will last for years. It is possible, however, to ruin a set of matrices in a short time by burring or damaging the teeth. The cause of the tooth combinations becoming injured is invariably due to bad alignment at one or possibly all of the various transfer points.

There are three of these transfers; that is to say, the matrices are transferred at three distinct points where the teeth are involved.

The first transfer is from the first elevator jaw to the second elevator bar at the intermediate channel. A matrix, when in position in the first elevator jaw at the transfer point, should line with the bar so that a perfect transfer to the bar can be obtained without binding. There is an adjusting screw at the bottom of the first elevator slide, on the right-hand side, for raising or lowering the slide. The alignment of the first elevator jaw rails and the intermediate channel rails should be perfect. This will take care of the vertical alignment.

Then, to take care of lateral alignment at the point where the matrix is supported by the first elevator jaw rails, and is just sliding on to the second elevator bar, there is an intermediate channel front plate extension which, by means of screw bushings, makes it possible to move the second elevator bar either toward the front or the rear, as may be desirable to secure a true aligning condition of matrix teeth and bar. This is one of the most important adjustments from the standpoint of the matrix teeth, and it should be handled with care to see that the bar is parallel with the channels. The second elevator bar should, of course, be perfectly smooth and free from burrs, as should be the other two bars along which the matrix must travel.

The second transfer is from the second elevator bar to the distributor box

bar. The second elevator, when in its normal position, should be so adjusted that the second elevator bar will line up with the distributor box bar.

The third transfer is from the distributor box rails to the distributor bar. These rails should be perfectly square with one another. Place a matrix on the distributor box rails and raise up the outside distributor screw; turn the distributor screws slowly by hand and see that the matrix when supported on the distributor box rails will transfer freely on to the distributor bar.

Perfect alignment should be maintained at all the above mentioned points. It is to the advantage of the Linotype user, in the interest of the long life of matrices, to occasionally check these adjustments and to make slight corrections that may be found necessary.

### **Repairing Damaged Lugs**

If the lugs of matrices become bent, straighten them with a pair of parallel jaw pliers. If a hammer is used to straighten them, care should be taken not to hammer them hard enough to distort their shape.

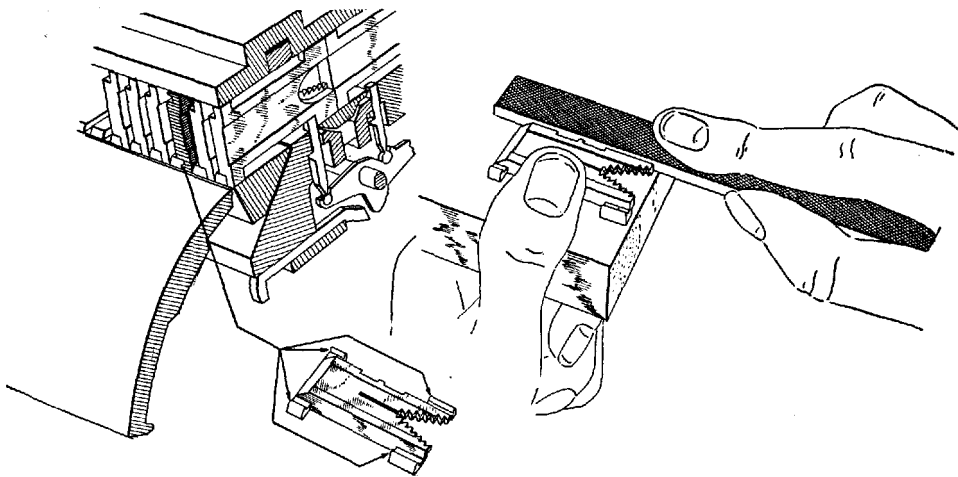

*View of portion of magazine and matrix, showing ear burred or sharp edge thrown up which prevents rapid and smooth sliding of matrix through the channel in the magazine. In this view the burr, or projection in the matrix is exaggerated. At the right in this view is shown a board, a matrix, and the method in which the burr, or projection can be removed with a fine file. In using a file in this way, only one with a safety edge should be used, and care must be taken not to file away the body, or main portion of the ear, but only the raw edge or burr upon the ear. If too much is filed away, especially on thin matrices, the lugs will probably catch in the escapement verge pawls.*



### *Preventing Hairlines*

Care should be taken to preserve the side walls of matrices. When they are damaged, hairlines will show in the printed matter.

One of the most common causes of damaged side walls is the excessive use of oil on the felt of the back mold wiper or around the machine where it comes in contact with the matrices. In a perfectly justified line there is always a slight amount of air space between the matrices, but not enough to permit metal to pass through. Hot oil, however, has a peculiar capillary attraction for hot metal. Oil from the back mold wiper will flow ahead of hot metal, through the mold and into the small air spaces between the matrices. The hot metal under pressure of the plunger will follow this track of hot oil between the matrices and in time adhere to the side walls. The accumulation on the side walls will gradually build up until they are crushed, and then fins or hairlines will appear between the characters.

If the spacebands are not cleaned regularly, and metal is allowed to accumulate on the sleeves at the casting point this metal will press against the side walls of the matrices, crushing them during the process of justification when the line is wedged tight between the vise jaws, and a font of matrices may be ruined in a very short time. The spacebands must be cleaned at least once during every eight hours of operation.

To clean spacebands, use a soft pine board sprinkled with Dixon's Graphite No. 635, and rub the sleeve of the spaceband to remove any metal that might show at the casting point. If the metal does not rub off easily, scrape with a piece of brass.

Damaged side walls may also be caused by loose lines in combination with an imperfectly adjusted pot pump stop which is actuated by the right-hand vise jaw. See that the pot pump stop is adjusted and the right-hand vise jaw moves freely to prevent casting unless the line is tightly justified.

If tight lines are sent in, the inside lugs of the matrices will be sheared or burred when the mold comes against them, especially if the vise automatic is out of adjustment and the machine goes too far ahead before throwing out the clutch. If a tight line is sent in and stops between the jaws, it should be possible to lift the first elevator slide to remove a matrix from the jaws without turning the machine backward. Care should be taken in these matters as many matrices may be otherwise damaged at this point.

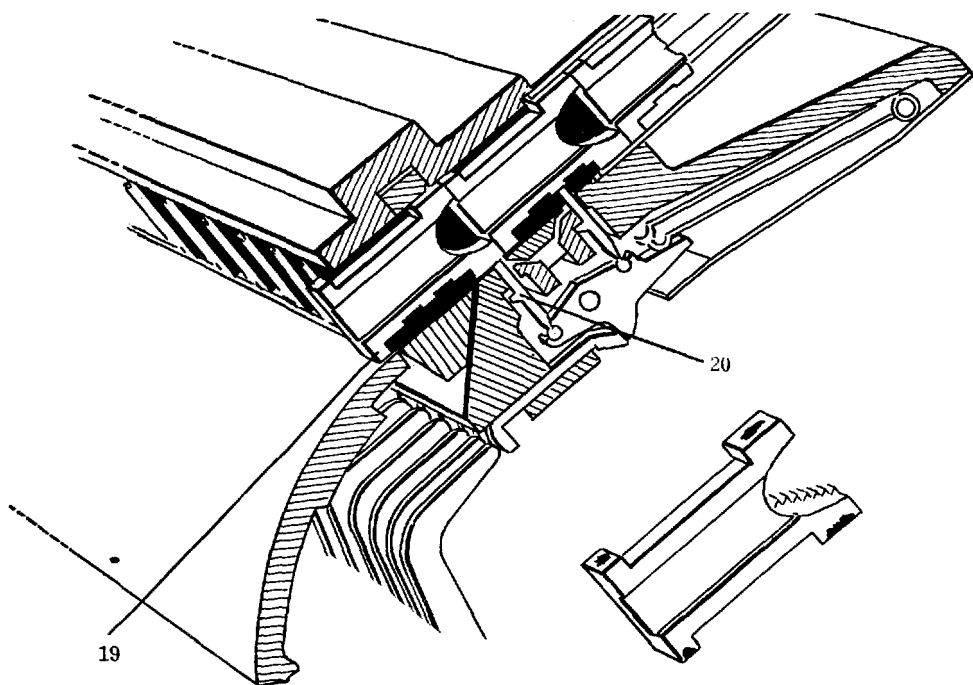

*View of a portion of a magazine, the escapement and escapement levers, and an enlarged view of the matrix, showing where dirt and gum may accumulate on the matrix lug and prevent its smooth, quick action. The matrices must be kept clean.*

*The lower lug of the matrix is shown at 19. The original dimension of the lug from front to back is .125". If this lug is sheared or worn too much, when it passes over the hole through which the escapement pawl 20 works, it is apt to fall into the opening and prevent the matrix from dropping.*

## Cleaning Matrices

In the first place, care should be exercised to keep matrices clean. Avoid excessive use of graphite, handling with greasy hands, excessive oil in lubrication, etc. (See "Do and Do Not"). When matrices need cleaning, the simplest methods seem to be the best. One of the best known ways is the use of a wire buffer and matrix holder, shown on next page. The buffer is made of very fine wire, is about five inches in diameter and is designed to fit on the arbor of any standard composing-room saw. The holder of the matrices is 20 inches long. With this equipment a font of matrices can be cleaned in a very short time, and by turning the holder at right angles to the buffer it is possible to clean the gum from the sides of the lugs except on the thin matrices. The buffer is

available with a  $\frac{1}{2}$ " hole (X-1673), and with a  $\frac{11}{16}$ " hole (X-1674). The holder is listed as X-1672.

Another method of cleaning matrices is Dixon Matrix Reference Cleaner (X-1604). Place a row of matrices on a type galley and polish the reference side; reverse the matrices and polish the lower lugs. If the lugs have gum on the sides, it may be necessary to rub the matrices over a soft felt to remove it.

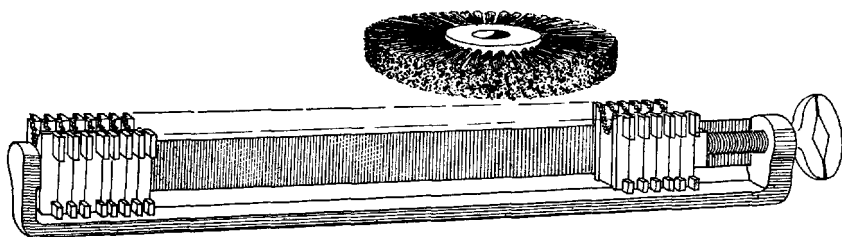

*The wire buffer and matrix holder may be used for cleaning matrices. The buffer may also be used for polishing various other machine parts without damage to them, such as keyboard cams and yokes, key levers, trigger ends, verge escapements, assembler slides, etc.*

Graphite should never be used on the matrices or in the magazine. It may make the matrices drop well for a short time but in damp weather it is likely to cause gum to accumulate.

The principal cause of gum on the matrices and magazines is *the excessive use of oil*, particularly on the distributor screw bearings. At no time should oil show on the screws, as it eventually gets on the matrices and into the magazines. If a good quality of oil is used, one drop in each bearing every two weeks should be sufficient.

### ***The Treatment of New Matrices***

In order to secure the best results when new fonts of matrices are used in outstanding Linotypes, a few precautionary measures should be taken. For years, Linotype has issued the following instructions in each box of fonts of matrices. Adherence to these simple rules may prevent trouble later.

Magazines and spacebands should be thoroughly cleaned.

Spacebands which are rounded or damaged at the casting edge or which have the slightest particle of metal adhering to the sleeve at the casting point will damage the side walls of new matrices very quickly.

Spacebands which have been bent and improperly straightened, that is,

wedges with kinks or buckles in them, will permit metal to flow between the wedge and the adjoining matrix.

All spacebands should be carefully micrometered and inspected with a knife straight edge for rounded corners on the sleeves. They should show a micrometer reading which is *even* when measuring sleeve and wedge together at the casting point on the spaceband and on the front of the band or a *plus* measurement on the casting side up to .0005 inch. In no case should bands be used which are *minus* on the casting side. If the corner of the sleeve at the casting point is found to be rounded when examining the bands with a knife straight edge, or with a new piece of hairline rule if a straight edge is not available, new sleeves should be applied, as metal will quickly gather at the casting point of the sleeve under this condition when used with brand new matrices.

Both front lockup adjustments should be inspected and properly corrected if this is found to be necessary.

While it is possible on old machines to secure satisfactory results with spacebands which are worn and rounded and with front lockup adjustments slightly off, this is possible because of the gradual building up of false side walls on the matrices, and the fact that the wrong condition of spacebands and adjustments gradually came into existence. However, when new matrices are installed, trouble will surely be experienced because of the wrong conditions in the machine and spacebands.

Before using new matrices in an old machine it is also important that the vise jaws be checked for squareness, since after a number of years service these jaws will show wear, causing hairlines. To avoid this condition, it is advisable to have these vise jaws reground.

At the face alignment position of the machine you should be able to lift the first elevator by hand .010 inch, and this measurement should not be exceeded. When two-letter 18- and 24-point matrices are used, this figure is reduced to .005 inch. This test is to be made with a thirty-em line of matrices, without spacebands, in the first elevator jaws.

Carefully set the Pump Lever Stop Lever so that when the line is fully justified the stop lever will be open beyond the block on the pump lever not more than 1/64 inch.

First elevator link eyebolts and nuts, upper and lower, should be checked and if they show undue wear they should be replaced.

Other and important points that should be checked are the back and front mold wipers. Oil in any form used at these points will cause metal to collect on the side of the matrix, crush the side wall, and result in hairlines.

Do not use oil on pot pump plungers after cleaning them, nor should oil be used in the remelting furnace in an attempt to burn dirt out of the metal.

### Adjustment of Mold Cam Lever Eccentric Pin

To adjust Mold Slide so that there is proper clearance, between face of Mold and Matrix when justification takes place, the Mold Cam Roll Eccentric Pin must be adjusted when Mold Cam Roll is on section of Mold Slide Cam marked 83 which is the highest point of Cam, and when Mold Cam Roll is on point 83 and Eccentric Pin is properly adjusted the space between face of Mold and the Vise Jaws or Matrix should not be less than .003 or over .005. This must be determined by using a thickness gauge.

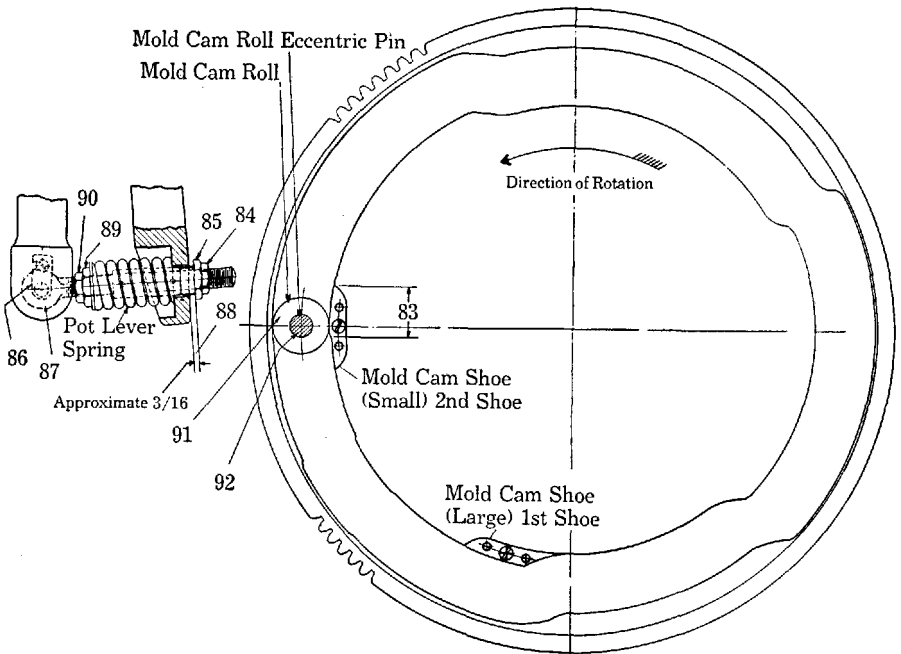

Before making the adjustment of Eccentric Pin, it will be necessary to release the pressure of Pot Lever Spring. This is done by removing Lock Nuts 84 and 85, Wing Pin 86 and Eyebolt 87. Lock Nuts 89 and 90 must not be disturbed.

When the adjustment is complete, restore parts 84, 85, 86 and 87 to original position, taking care that space 88 is approximately 3/16 of an inch when Pot is in casting position.

*To Conserve The Life of Your Matrices*

**DO**

Clean spacebands every eight hours of service.

**DO**

Renew the assembling elevator matrix buffer when it becomes worn. This is a small piece of fiber on the inside of the right-hand end of the assembling elevator. If worn it permits the incoming matrices to strike the steel back rail plate and damage the aligning lugs of the matrices.

**DO**

Renew assembling elevator detaining plates, front and back plate, when worn. These are small steel plates on the right-hand end of the assembling elevator at the bottom and support the matrices in an upright position during assembling.

**DO**

Renew assembling elevator gate pawls, front and back, if worn. They prevent the last matrix in the line from falling down and damaging side walls and lugs.

**DO**

Adjust the assembler chute finger to the proper angle to cause the incoming matrix to strike outside the side wall area of the preceding matrix in the line. This will prevent damage to side walls and the resultant hairlines.

**DO**

Clean matrices on the lugs only with a rubber eraser or a specially designed rotary metal brush, described elsewhere in this book.

**DO**

Remove promptly from fonts all matrices that show hairlines from crushed side walls or those that are bent or have badly bruised lugs. Such matrices will progressively damage the entire font if

allowed to remain in use and come in contact with good matrices during circulation. Many such matrices can be repaired and restored to useful service.

**DO**

See that the inside edge of the assembler cover (the small one covering the assembler block) does not project inwardly beyond the line of the inside edge of the large cover. Any projection will cause the matrix lugs to strike and raise a burr.

**DO**

See that the pot pump stop is working freely and adjusted to prevent casting short lines. A loosely justified line permits metal to run between matrices and crush side walls, resulting in hairlines.

**DO**

See that the teeth on the second elevator bar and distributor box bar are free of burrs which may damage the combination teeth.

**DO**

Pick up and return to the magazine promptly matrices that fall to the floor. Once stepped on or mixed with metal shavings they are sure to be damaged irreparably.

**DO**

Make it a practice to take font proofs occasionally of all characters cast in groups alphabetically. This will enable you to spot and remove damaged matrices before they contaminate the perfect ones.

**DO**

Replace star wheels when the edges become rounded. Worn star wheels do not push matrices inside of assembler gate pawls and detents, but cause them to fall back in the assembling elevator and become clogged and damaged.

## To Conserve The Life of Your Matrices

### DO NOT

*Do not* dump matrices loosely in a container for cleaning. If carbon tetrachloride is used for cleaning, arrange the matrices on a galley and carefully brush the lugs with a brush dipped in the liquid.

### DO NOT

*Do not* clean matrices with any liquid solvent containing chromic acid. This acid is a brass solvent. Even a weak solution will pit the character, destroy the side walls and cause metal to adhere to the sides, resulting in defective type surfaces on the slug and *hairlines* between the characters.

### DO NOT

*Do not* use oil on the back mold wiper or to excess in other places where it can come in contact with matrices. Oil on the sides of matrices makes a path for molten metal to be forced between them. This metal gradually builds up on the side and the walls eventually become crushed and produce *hairlines*.

### DO NOT

*Do not* operate the keyboard or handle matrices with dirt or grease on your hands. Keep your hands and the machine clean. Greasy dirt is the worst enemy of matrices.

### DO NOT

*Do not neglect* to clean spacebands once every eight-hour shift. If polished with loose graphite see that loose particles are removed before returning spacebands to the box.

### DO NOT

*Do not* use graphite on matrices or in magazines. Moisture on the hands or a humid atmosphere causes graphite to

form an oily deposit which eventually becomes a hard cake on the sides of the matrices and in the channels. This condition results in the necessity of frequent cleaning and naturally leads to damage through unnecessary handling. The lugs of the matrices may be polished with dry graphite after cleaning.

### DO NOT

*Do not* force a tight line into the vise jaws. This practice causes the aligning lugs to be sheared and irreparably damaged, and is hard on the spacebands.

### DO NOT

*Do not* send in loose or short lines unless you are sure the pot pump stop safety is operating perfectly. A front squirt may ruin several dollars' worth of matrices and spacebands. A little care at this point pays good dividends in time and money.

### DO NOT

*Do not* remove matrices that may have become wedged tightly in a jumbled line in a careless or forceful manner. Go about it easily and carefully, remembering that an average 12-em line contains about \$6.00 worth of matrices and spacebands.

### DO NOT

*Do not fail* to replace that worn star wheel promptly, and thus guard against sending in tight lines.

### DO NOT

*Do not* overlook the importance of keeping the pawls in first elevator jaws in good condition. They prevent matrices falling out of the jaws in recasting, which invariably results in serious damage.

---

# LINOTYPE LUBRICATION

---

*NOTE: The illustrations appearing on the following pages indicate the oiling points of Models 29, 30, 31 and 32 and the Self-Quadder. However, they will be found helpful in lubricating other models.*

To insure a long life of efficient and trouble-free operation, a systematic plan of machine maintenance should be followed. In this plan, proper lubrication is the most important single factor. So that this may be accomplished in a thorough and systematic manner, there are indicated in the following photographs all of the various oiling points on the machine. In some cases two or more oil holes are shown in one location, and are indicated as (2).

The oil holes are placed in the most convenient and accessible positions practicable. It should be remembered that a few drops of oil applied frequently is more economical and much more efficient than flooding the parts with oil occasionally. In addition to wasting oil, flooding only helps to collect dirt, and in all probability does more harm than good. A piece of waste or cloth should be used to remove all surplus oil from around holes after oiling. Extreme care should be used to prevent any oil from coming in contact with the matrices as it will eventually hinder smooth assembling action.

It is not possible to indicate the desirable frequency of oiling individual points on the Linotype, as is practicable in the case of an automobile. The widely varying conditions under which Linotypes are operated, with respect to running time, cleanliness and climate, combine to make it a problem best solved locally, through the exercise of simple mechanical judgment. It should be sufficient to point out that the constantly moving parts call for more frequent attention than those which only contact when the machine makes its periodic cycles.

Particularly important to proper lubrication is the quality of the lubricant. Cheap vegetable oils are a false economy. Always use high-grade machine oils that will not gum. We recommend Linotype oil and grease as it has been thoroughly tested and found efficient. As a guide, with regard to quality and viscosity, we have indicated throughout, by symbol, the proper lubricant for each oiling point. As will be noted, the proper grade oil in the majority of places is our X-24, a medium-weight motor oil (standard S.A.E.20).

## *Linotype Approved Lubricants*

### **\* Linotype Oil**

Part No. X-24 (½ gallon can)

### **† Keyboard and Distributor Oil**

Part No. X-1012 (2 oz. bottle)

### **‡ Keyboard Cam Oil**

Part No. X-101 (2 oz. bottle)

### **§ Linotype Grease**

Part No. X-1204 (5 lb. can)



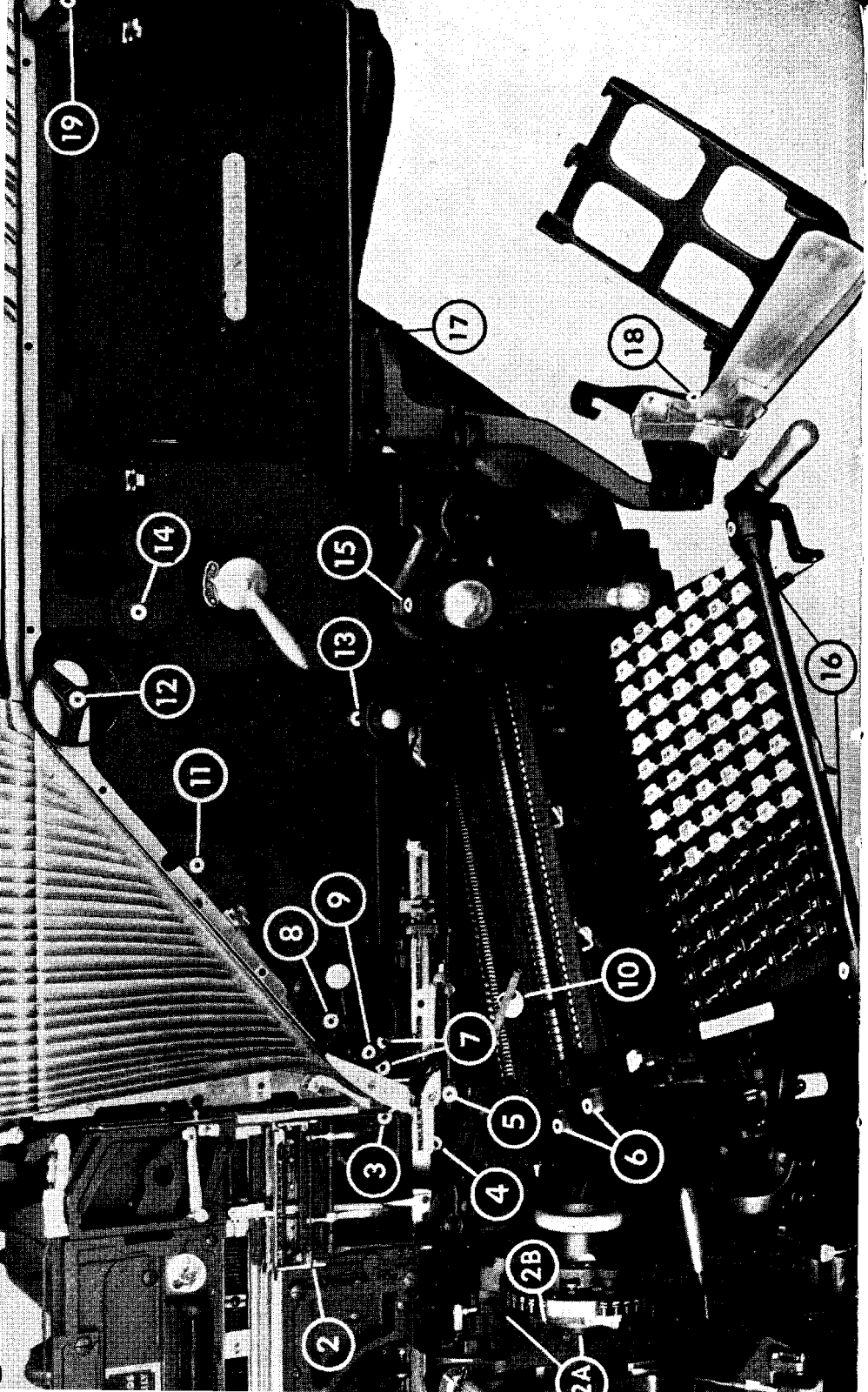

- 1** Second Elevator Guide (Lower) (Apply oil sparingly with finger) †  
Also oil hinge pins in Second Elevator sparingly †
- 2** Assembling Elevator Gate Spring Roll †
- 2a** Knife Block Slide Oil Holes (2) \*
- 2b** Knife (R.H.) Slide Pusher Cam (Oil bearing surfaces) \*
- 3** Assembler Star Shaft Oil Hole \*
- 4** Assembler Slide Roll Oil Hole \*
- 5** Keyboard Rod Shift Key Link Lever Shaft Oil Holes (2) (Except 72-90 machines) \*
- 6** Keyboard Cam Rubber Roll Shaft Oil Holes (4) \*
- 7** Assembler Star Idler Pinion Oil Holes (2) \*
- 8** Matrix Delivery Belt Driving Pulley Shaft Oil Hole \*
- 9** Assembler Star (Inter.) Gear Oil Hole \*
- 10** Keyboard Cams should be removed and cleaned occasionally and a small drop of oil applied to the pin with a toothpick †
- 11** Keyboard Rod Shifter Guide Oil Holes (3) (Except 72-90 machines) (Cover must be removed to oil) \*
- 12** Matrix Delivery Belt Idler Pulley Oil Hole \*
- 13** Assembler Slide Return Spring Stud Bearing Oil Hole \*
- 14** Matrix Delivery Belt Idler Pulley (Aux.) (Small) Oil Hole (Models 30 and 32) \*
- 15** Magazine Elevating Shaft Crank Shaft Oil Hole \*
- 16** Assembling Elevator Lever Shaft Oil Holes (2) \*
- 17** Pi Stacker Support Oil Hole \*
- 18** Pi Star Shaft Oil Hole \*
- 19** Matrix Delivery Belt Idler Pulley (Aux.) Oil Hole (Models 30 and 32) \*

*Note: On late machines oil holes will not be found at points 3, 6, 7, 8, 9, 12, 14 and 19. These places are now supplied with Oilite bearings which eliminate the necessity for manual oiling.*

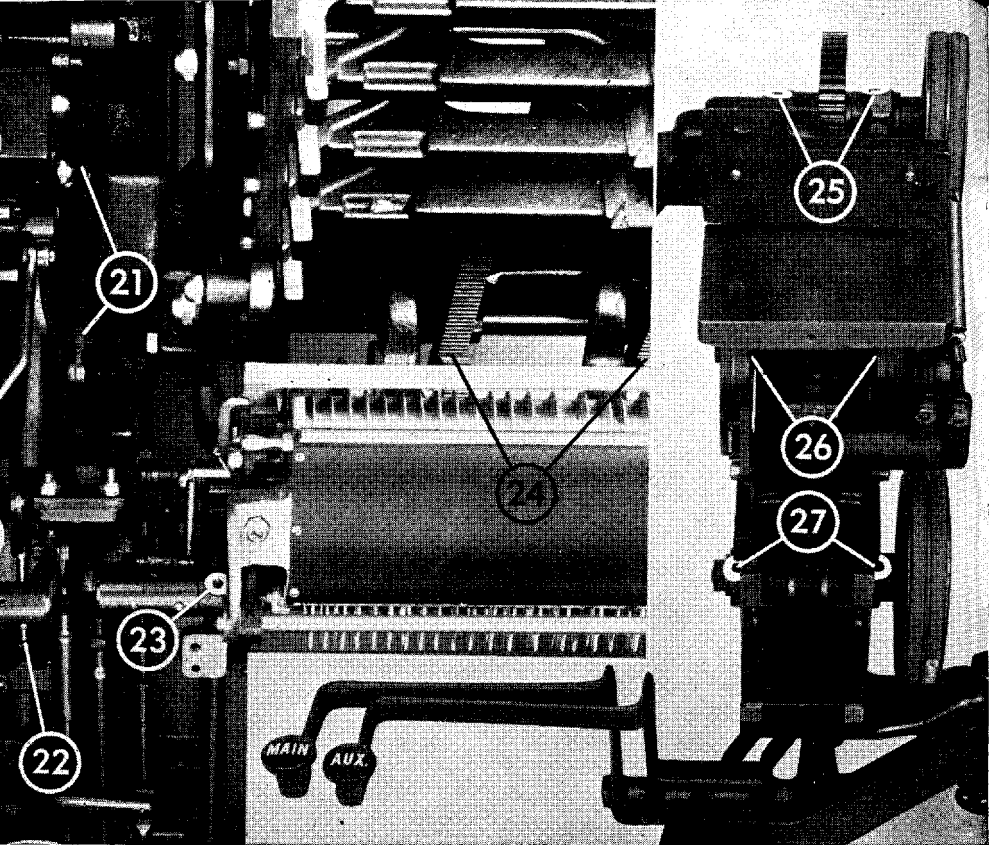

- 20** Assembler Entrance (Upper) Hinge Shaft Oil Holes (2) (one on each end of Shaft) (Models 29 and 30) \*
- 21** Pivoting Front Guide Holder Balance Spring and Operating Cam Roll (Apply oil to Plunger Rod and Roll) (Models 29 and 30) \*
- 22** Assembler Entrance (Upper) Snubber Piston (Apply oil to Plunger Rod) (Models 29 and 30) \*
- 23** Assembler Entrance (Upper) (Aux.) Hinge Shaft Oil Holes (2) (one on each end of Shaft) (Model 30) \*
- 24** Magazine (Aux.) Elevating Pinion Racks and Gears (Models 30 and 32) \*

- 25** Assembler Entrance (Upper) Shift (Inter.) Driving Gear Shaft Oil Holes (one on Model 29) (two on Model 30) †
- 26** Assembler Entrance (Upper) Finger Key Shift Operating Cams and Rolls (one on Model 29) (two on Model 30) †
- 27** Assembler Entrance (Upper) Finger Key Shift Operating Cam Shaft Oil Holes (2) (Models 29 and 30) †

*Apply oil sparingly to all bearing surfaces not provided with oil holes. Do not allow any oil to get on Assembler Entrance (Upper) Finger Key Shift Roll Cams.*

#### **OPPOSITE PAGE:**

- 28** Distributor Shifter Lever Shaft Oil Holes (2) (one on each end of shaft) \*
- 29** Pot Pump Lever Oil Holes (3) \*
- 30** Pot Crucible Vertical Mouthpiece Wiper Shaft Oil Holes (2) \*
- 31** Mold Turning Square Block Shaft Oil Holes (2) \*
- 32** Mold Turning Cam Shoes (2) (Oil felt on Gear Guard) \*

- 33** Mold Turning Bevel Pinion (Apply oil to teeth of Gear and sides of square block) \*
- 34** Vise Closing Cam Roll Oil Holes (2) \*
- 35** Justification Cam Roll Oil Holes (2) \*
- 36** Vise Jaw Locking Toggle Lever Oil Hole (Self-quadder) \*
- 37** Vise Jaw Locking Toggle Lever and Control Rod Lever Shaft Oil Holes (2) (Self-quadder) \*

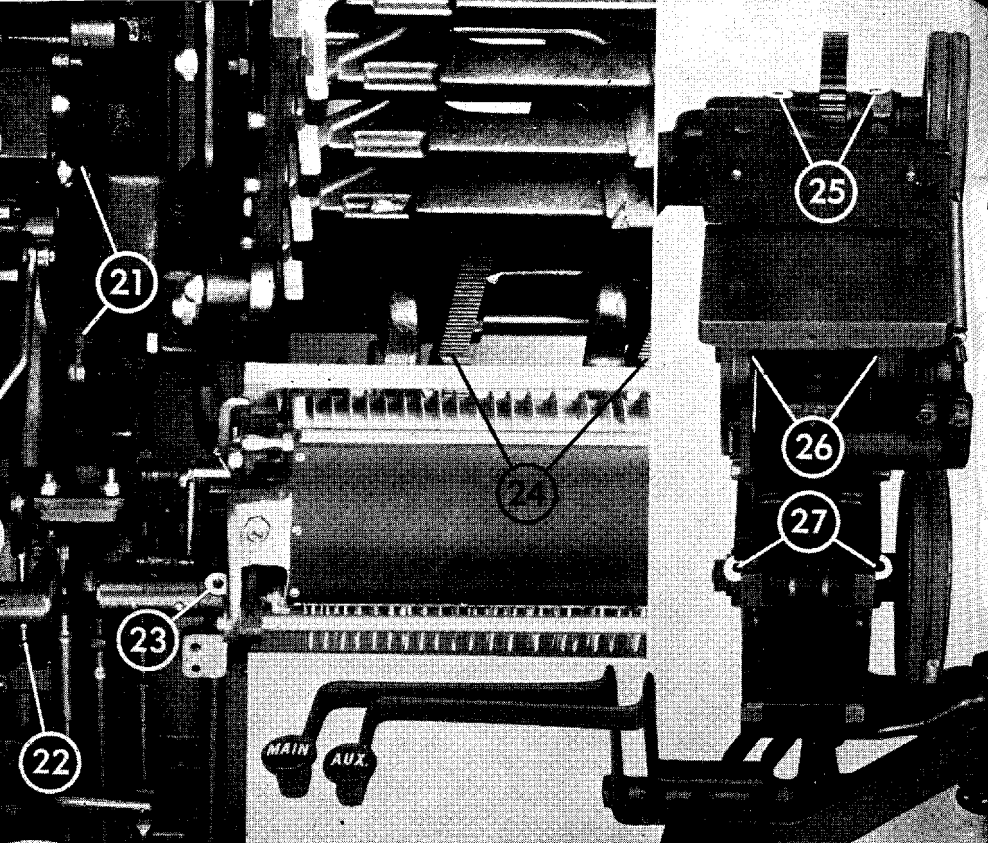

- 20** Assembler Entrance (Upper) Hinge Shaft Oil Holes (2) (one on each end of Shaft) (Models 29 and 30) \*
- 21** Pivoting Front Guide Holder Balance Spring and Operating Cam Roll (Apply oil to Plunger Rod and Roll) (Models 29 and 30) \*
- 22** Assembler Entrance (Upper) Snubber Piston (Apply oil to Plunger Rod) (Models 29 and 30) \*
- 23** Assembler Entrance (Upper) (Aux.) Hinge Shaft Oil Holes (2) (one on each end of Shaft) (Model 30) \*
- 24** Magazine (Aux.) Elevating Pinion Racks and Gears (Models 30 and 32) \*

- 25** Assembler Entrance (Upper) Shift (Inter.) Driving Gear Shaft Oil Holes (one on Model 29) (two on Model 30) †
- 26** Assembler Entrance (Upper) Finger Key Shift Operating Cams and Rolls (one on Model 29) (two on Model 30) †
- 27** Assembler Entrance (Upper) Finger Key Shift Operating Cam Shaft Oil Holes (2) (Models 29 and 30) †

*Apply oil sparingly to all bearing surfaces not provided with oil holes. Do not allow any oil to get on Assembler Entrance (Upper) Finger Key Shift Roll Cams.*

#### **OPPOSITE PAGE:**

- 28** Distributor Shifter Lever Shaft Oil Holes (2) (one on each end of shaft) \*
- 29** Pot Pump Lever Oil Holes (3) \*
- 30** Pot Crucible Vertical Mouthpiece Wiper Shaft Oil Holes (2) \*
- 31** Mold Turning Square Block Shaft Oil Holes (2) \*
- 32** Mold Turning Cam Shoes (2) (Oil felt on Gear Guard) \*
- 33** Mold Turning Bevel Pinion (Apply oil to teeth of Gear and sides of square block) \*
- 34** Vise Closing Cam Roll Oil Holes (2) \*
- 35** Justification Cam Roll Oil Holes (2) \*
- 36** Vise Jaw Locking Toggle Lever Oil Hole (Self-quadder) \*
- 37** Vise Jaw Locking Toggle Lever and Control Rod Lever Shaft Oil Holes (2) (Self-quadder) \*

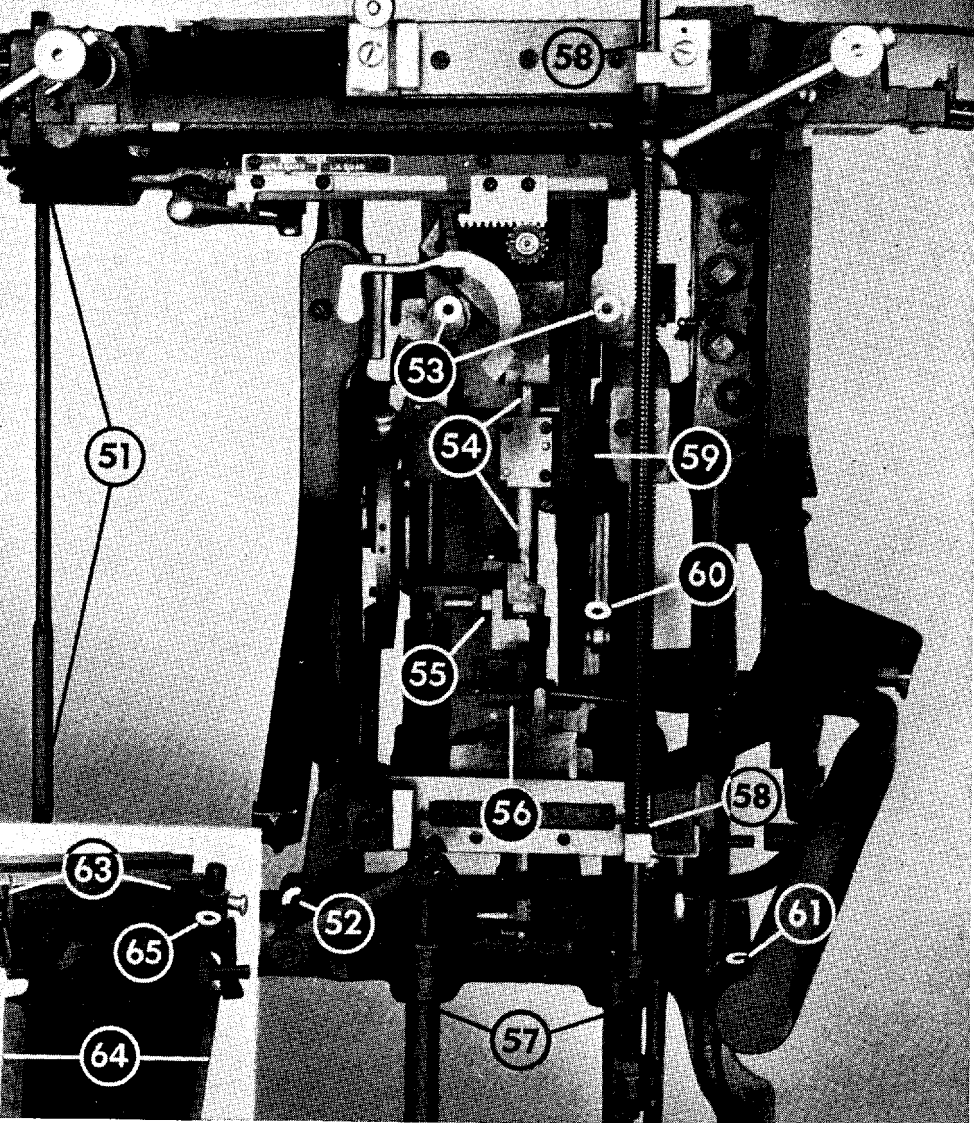

**51** Vise Jaw (L.H.) Wedge (Apply oil to bearing surfaces) \*

**52** Slug Lever Arm Shaft Oil Hole \*

**53** Vise Jaw Operating Lever Fulcrum Stud Oil Grooves (2) (Self-quadder) †

**54** Vise Jaw Control Rod (Apply oil to sides of Rod) (Self-quadder) †

**55** Justification Control Cam (Apply oil to bearing surface) (Self-quadder) †

**56** Vise Jaw Locking Toggle Adjusting Screw Cam Oil Hole (Self-quadder) †

**57** Justification Rods (2) (Apply oil to sides of Rods) \*

**58** Knife Wiper Bar Rod (Apply oil to sides of Rod) \*

**59** Mold Disk Dog (Apply oil to sides of Plunger) †

**60** Vise Automatic Stop Rod Lever Oil Hole †

**61** Slug Lever Oil Hole \*

**62** First Elevator Jaw Duplex Rail (Oil sparingly) ‡

**63** First Elevator Jaw Duplex Rail Levers (Oil sparingly) ‡

**64** First Elevator Slide (Apply oil to bearing surfaces) \*

**65** Knife Wiper Operating Lever Oil Hole \*

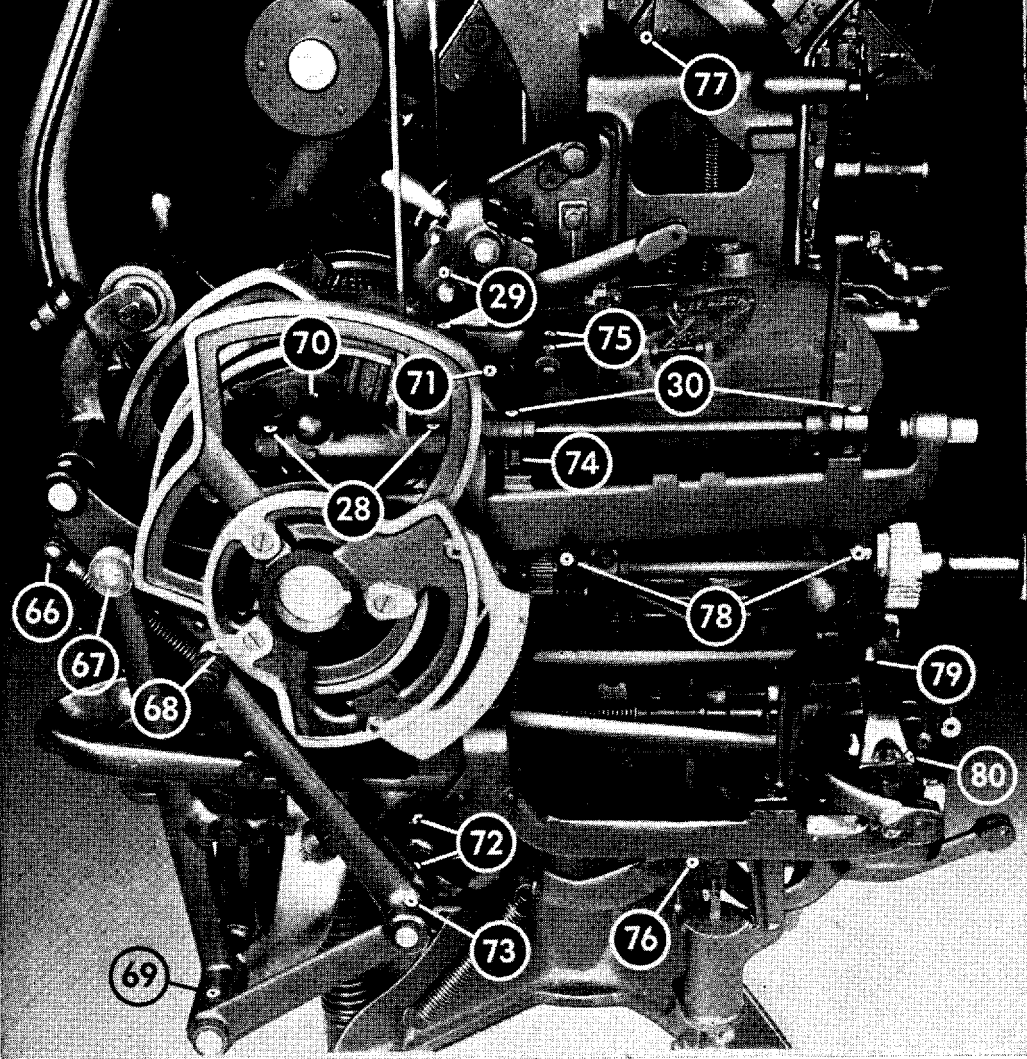

- 66** Second Elevator Starting Spring Bolt Hinge Screw (Models 31 and 32) \*
- 67** First Elevator Cam Roll Oil Hole \*
- 68** Vise Jaw Locking Toggle Cam Roll Oil Hole (Self-quadder) \*
- 69** Vise Jaw Locking Cam Lever Bracket Support Oil Hole (Self-quadder) \*
- 70** Distributor Shifter Cam and Cam Rider \*
- 71** Pot Pump Lever Roll Oil Holes (2) \*
- 72** Vise Jaw Locking Toggle Cam Lever Extension Arm Oil Holes (2) (Self-quadder) \*
- 73** Vise Jaw Locking Toggle Cam Roll Lever Oil Hole (Self-quadder) \*

- 74** Pot Cam Roll Oil Holes (2) \*
- 75** Pot Lever Oil Holes (2) \*
- 76** Vise Jaw Locking Toggle Lever Roll Oil Hole (Self-quadder) \*
- 77** Magazine Locating Block Support Lever Shaft Oil Holes (2) (one at each end of shaft) \*
- 78** Mold Disk Pinion Shaft Oil Holes (2) \*
- 79** Mold Disk Guide Support Screw Grease Cup §
- 80** Pot Leg Bushing Oil Holes (2) (one on each leg) \*

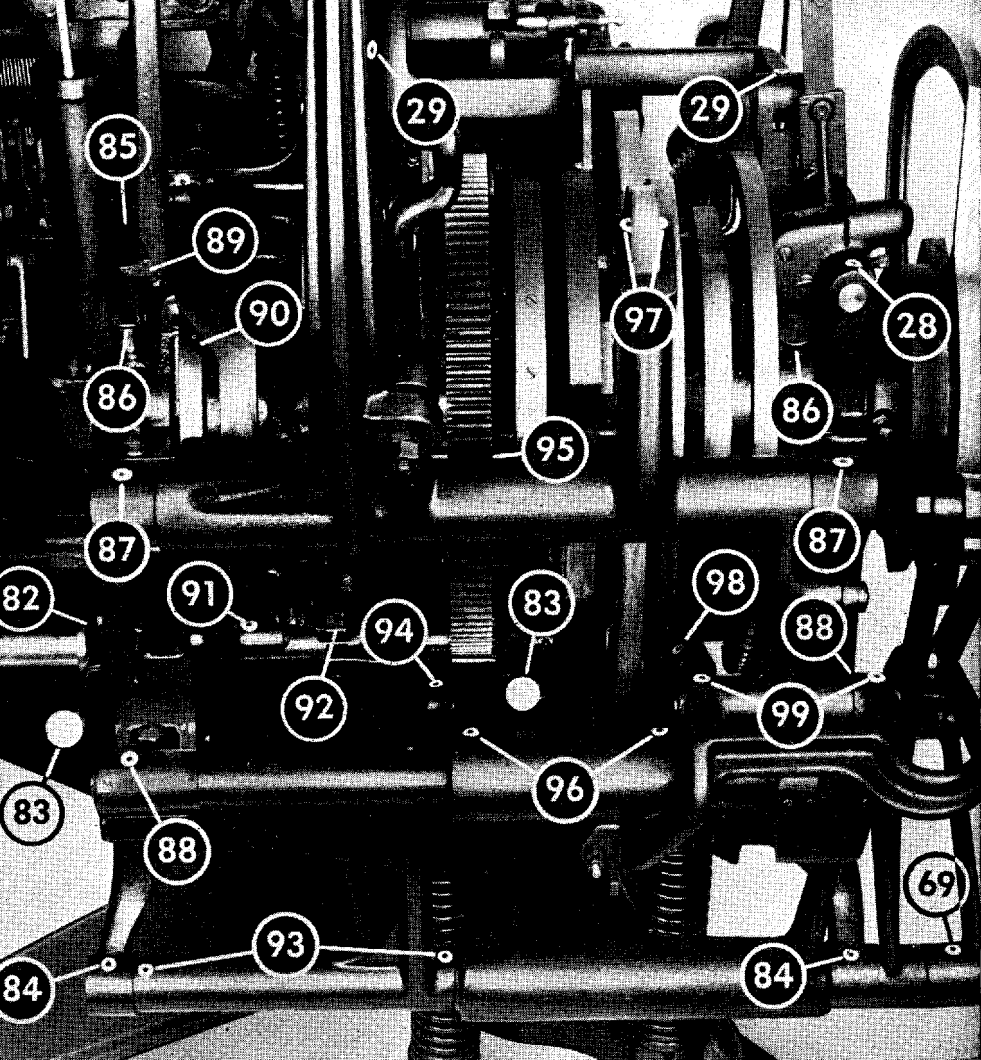

**81** Intermediate Shaft Driving Belt Idler Pulley Oil Cup (72-90 machines) \*

**82** Driving Shaft Clutch Flange (Oil bearing surfaces) \*

**83** Driving Shaft Bearing Grease Cups (2) §

**84** First Elevator and Ejector Lever Shaft Oil Holes (2) \*

**85** Delivery Lever Cam Roll and Pin \*

**86** Cam Shaft Grease Cups (2) §

**87** Second Elevator Lever Shaft Oil Holes (2) \*

**88** Justification and Vise Closing Lever Shaft Oil Holes (2) \*

**89** Elevator Transfer Cam Roll Oil Hole \*

**90** Delivery and Elevator Transfer Cam (Oil bearing surface) \*

**91** Second Elevator Safety Pawl Oil Hole \*

**92** Delivery Cam Shoe (Oil bearing surface) \*

**93** Ejector Lever Oil Holes (2) \*

**94** Vise Closing Lever Spring Rod Oil Hole \*

**95** Pot Return Cam (Oil bearing surface) \*

**96** Justification Lever Oil Holes (2) \*

**97** Second Elevator Cam Roll Oil Holes (2) \*

**98** Justification Lever Spring Rod Oil Hole \*

**99** Justification Release Cam Lever Oil Holes (2) (Self-quadder) \*



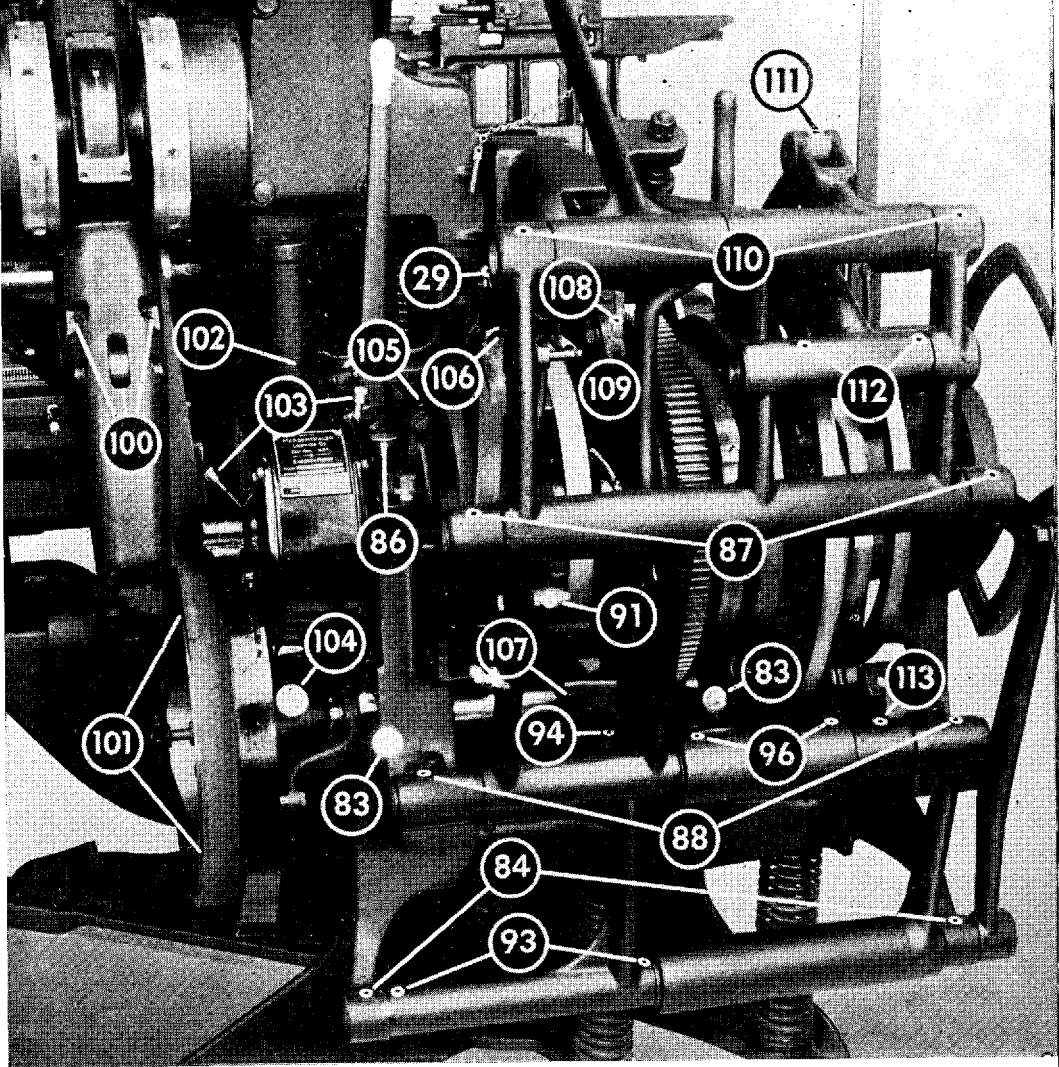

- 100** Magazine Elevating Shaft Anti-Friction Rolls (6) \*
- 101** Driving Shaft Friction Shoe Rods and Pins \*
- 102** Delivery Air Cushion Piston Fulcrum Screw \*
- 103** Motor Armature Bearing Grease Cups (2) (NOTE: A medium ball-bearing grease should be used on the type of motor illustrated. For older style motors having oil cups, use Linotype oil X-24.)
- 104** Motor Driving Pulley Grease Cups §
- 105** Vertical Starting Lever Shaft \*
- 106** Automatic Safety Pawl and Auto-

- matic Stopping Pawl (Oil bearing surfaces and hinge pins) \*
- 107** Ejector Lever Shoe (Oil bearing surface) \*
- 108** Ejector Lever Adjustable Pawl Plate (Oil bearing surface) \*
- 109** Ejector Lever Adjusting Pawl Oil Hole \*
- 110** Second Elevator Lever Shaft Oil Holes (2) (Models 29 and 30) \*
- 111** Second Elevator Lever Link Oil Holes (2) (Models 29 and 30) \*
- 112** Second Elevator Cam Lever Oil Holes (2) (Models 29 and 30) \*
- 113** Vise Closing Lever Oil Hole \*



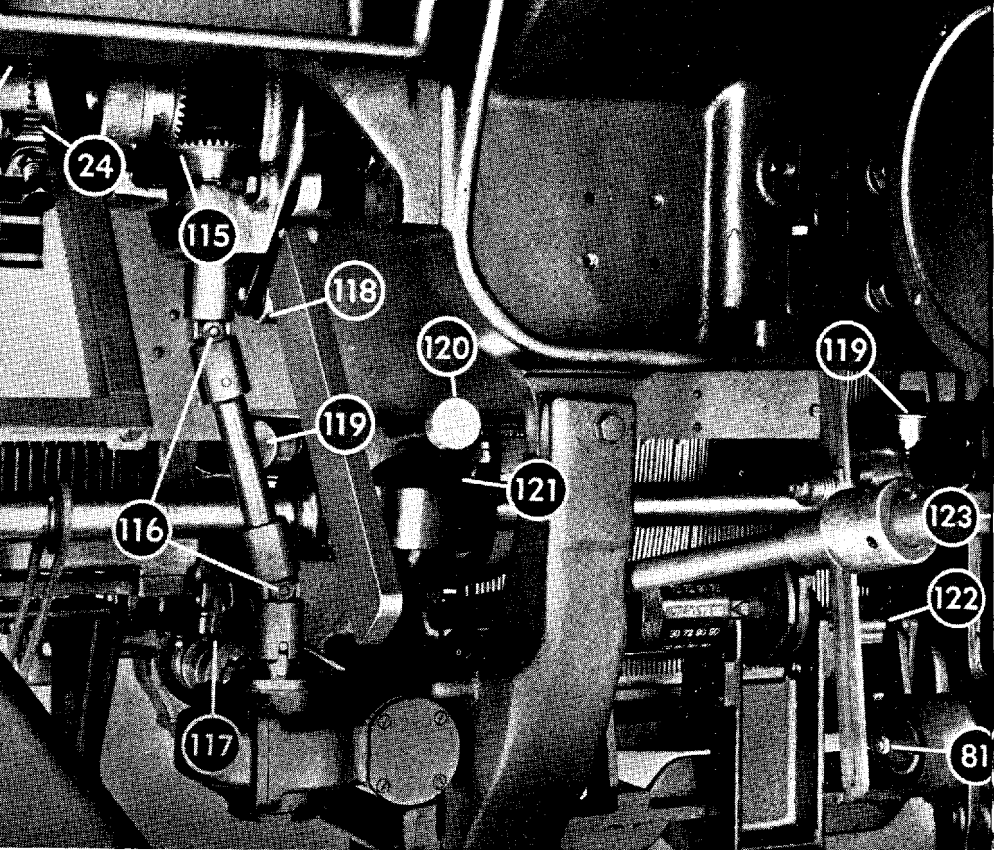

**114** Magazine (Aux.) Elevating Pinion Rack Guide Roll Oil Holes (2) (Oil holes are in face of Roll) (Models 30 and 32) \*

**115** Magazines (Aux.) Frame Elevating Shaft Gears (Models 30 and 32) \*

**116** Magazine (Aux.) Elevating Shaft Universal Joints (2) (Models 30 and 32) \*

**117** Magazine Elevating Shaft Clutch (one on Models 29 and 31) (two on Models 30 and 32) (Oil bearing surfaces) \*

**118** Magazine (Aux.) Frame Guide Rolls (4) (Models 30 and 32) \*

**119** Intermediate Shaft Grease Cups (2) §

**120** Assembler Driving Pulley Shaft Grease Cup §

**121** Intermediate Shaft Bevel Gear and Assembler Driving Belt Gear \*

**122** Keyboard Rod Lever Slide Link and Cam Roll Lever Shaft Oil Holes (3) (Models 31 and 32 [72-90]) \*

**123** Magazine Elevating Shaft Universal Joints \*

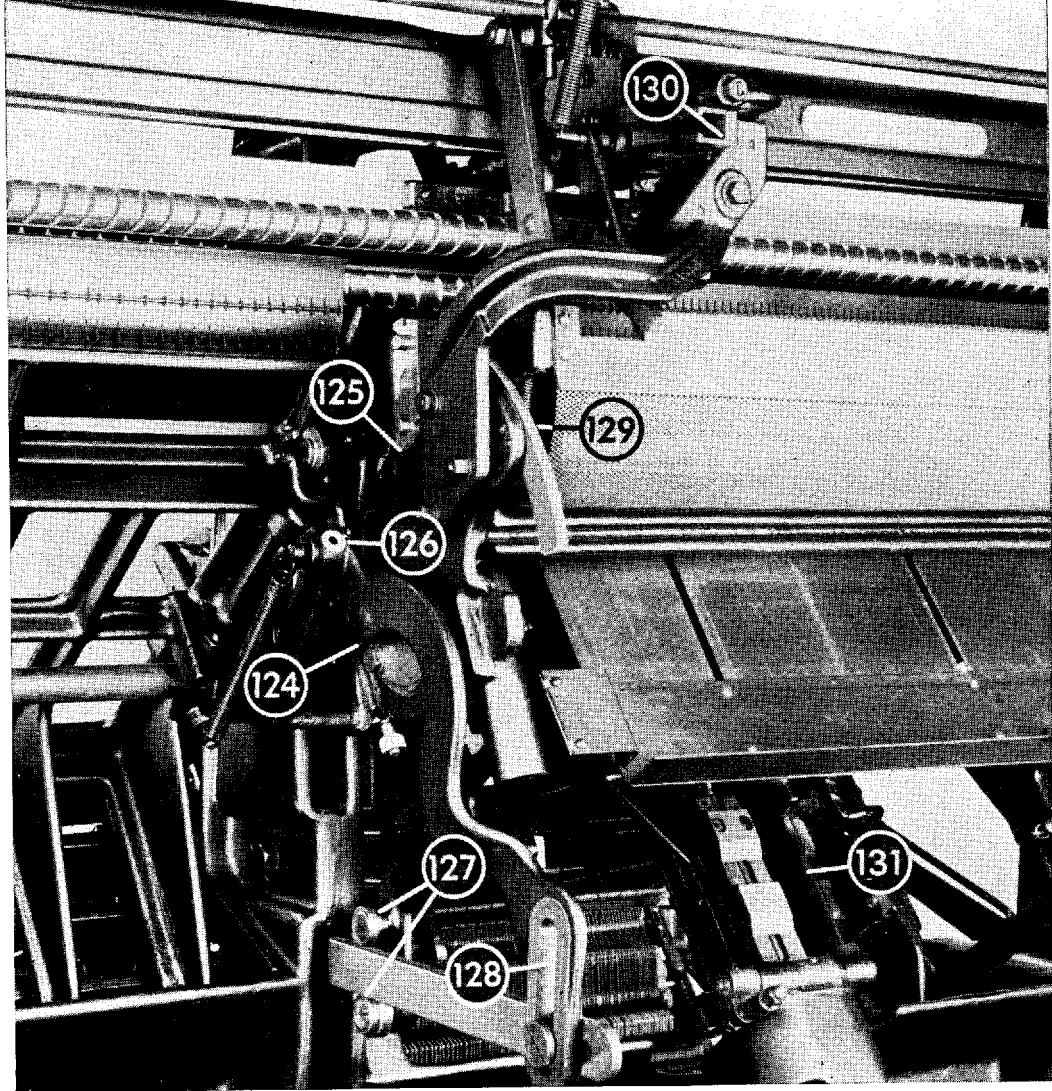

**124** Distributor Screw Guard Safety Lock (Oil bearing surfaces) (Models 31 and 32 [72-90]) †

**125** Channel Entrance Revolving Block (Oil bearing surfaces) (Models 31 and 32 [72-90]) †

**126** Channel Entrance Frame Control Lever Link Oil Holes (2) (one hole on front of Link) (Models 31 and 32 [72-90]) \*

**127** Channel Entrance Control Lever Link Guide Rolls (Oil studs) (Model 32 [72-90]) \*

**128** Channel Entrance Control Lever Link (Long) (Oil bearing surfaces) (Model 32 [72-90]) \*

**129** Channel Entrance Revolving Cams (Oil bearing surfaces) (Models 31 and 32 [72-90]) †

**130** Distributor Bar Shifter Guide (Oil bearing surfaces) (Models 31 and 32 [72-90]) †

**131** Magazine Frame (Lower) Guide Rails (2) (one on each side of frame) (Oil bearing surfaces) (Models 31 and 32) \*

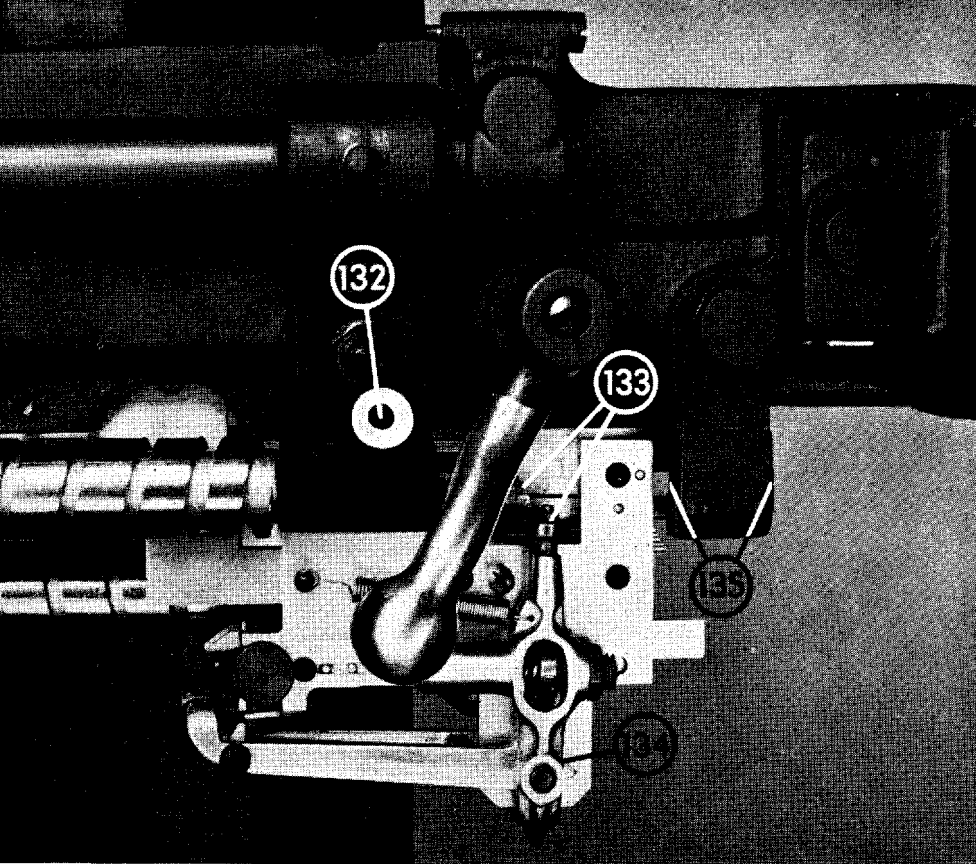

**132** Distributor Back Screw Oil Holes (2) (one hole at other end of screw) (Models 31 and 32) †

**134** Distributor Box Matrix Lift Cam Lever Oil Holes (2) (Models 31 and 32) †

**133** Distributor Box Matrix Lift Cam and Roll (Models 31 and 32) †

**135** Second Elevator Guide (Upper) (Oil bearing surfaces) †

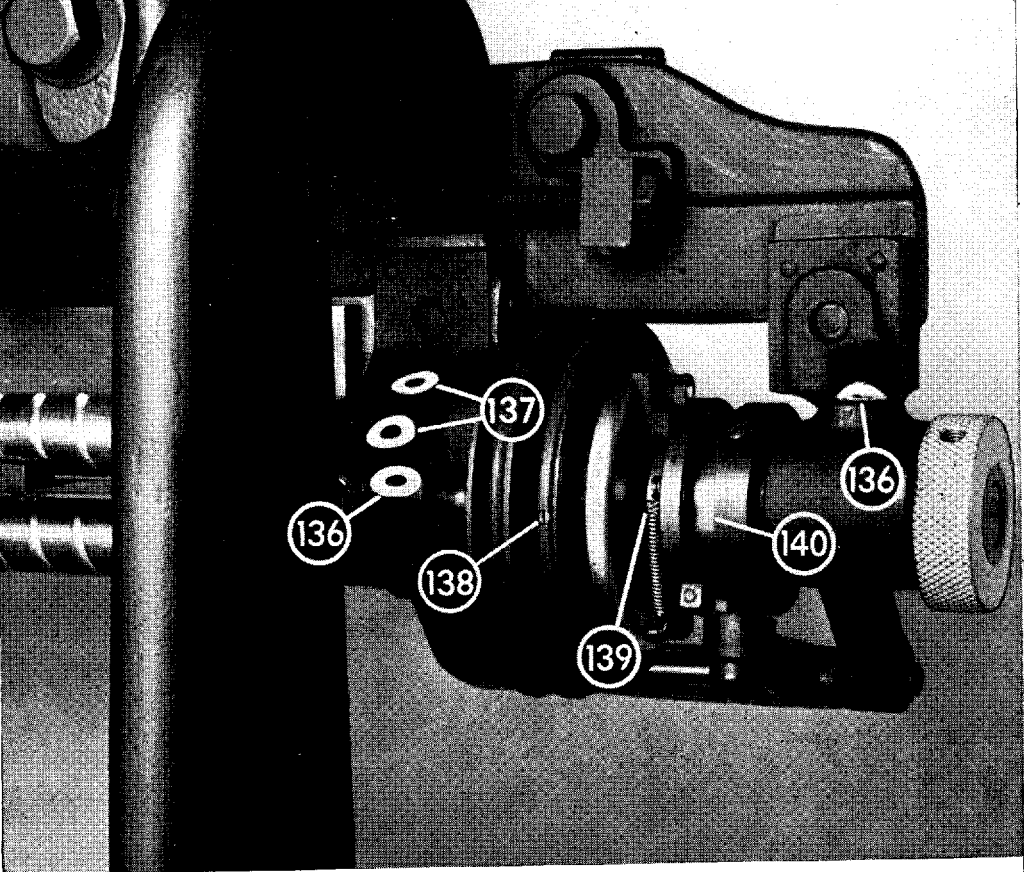

**136** Distributor Clutch Shaft Oil Holes  
(2) †

**137** Distributor Front Screw Oil Holes  
(4) (one hole at other end of each  
screw) (Models 31 and 32) †

**138** Distributor Clutch Pulley Oil Hole  
(Remove screw to oil) †

**139** Distributor Clutch Pulley Washer  
Flange Oil Hole †

**140** Distributor Clutch Flange Collar  
(Oil bearing surface) †

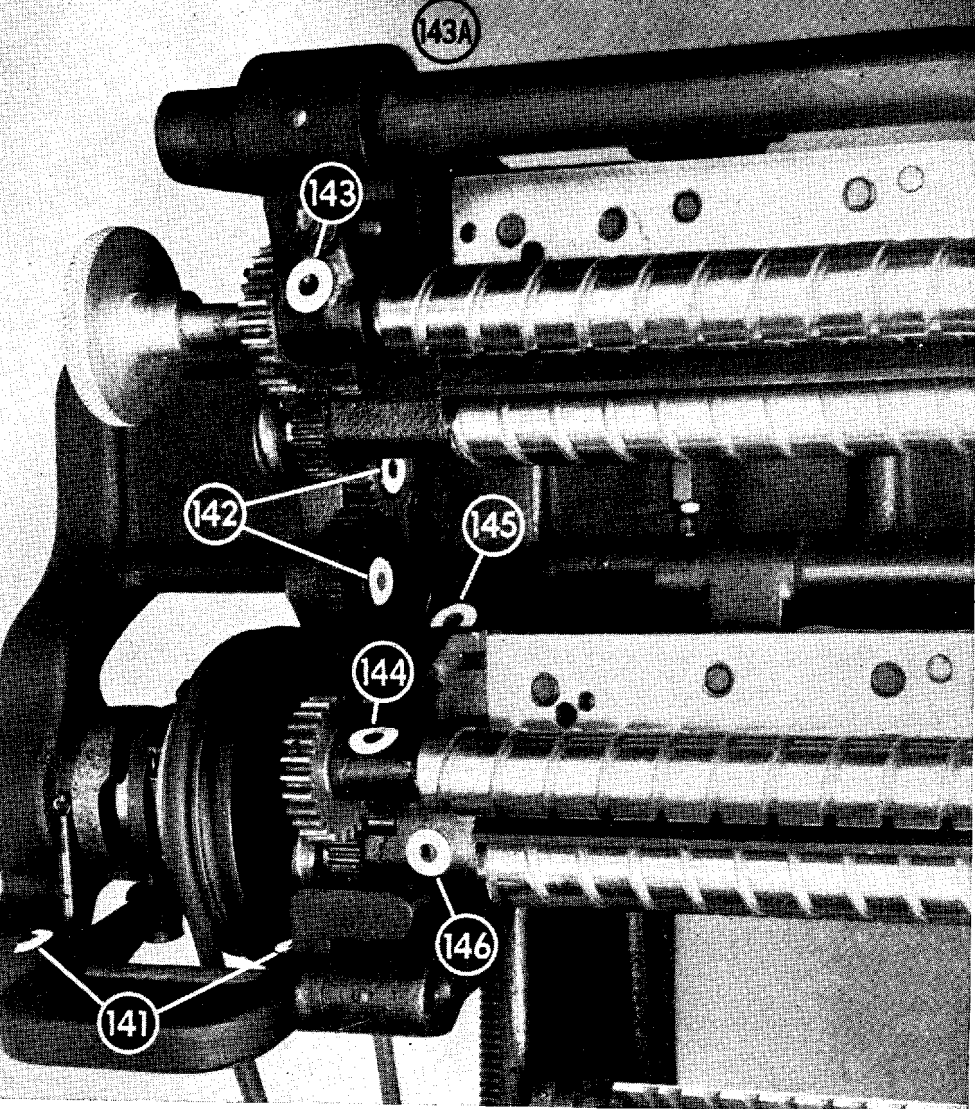

- 141** Distributor Clutch Lever Oil Holes (2) (Models 29 and 30) †
- 142** Distributor Screw Idler Gear Stud Oil Holes (4) (holes in head of each stud) (Models 29 and 30) †
- 143** Distributor Back Screw (Upper Set) Oil Holes (2) (one hole at other end of screw) (Models 29 and 30) †
- 143a** Distributor Front Screw (Upper Set) and Distributor Lower Screw (Upper Set) Oil Holes (4) (one hole

at each end of each screw—visible from top of machine) (Models 29 and 30) †

- 144** Distributor Back Screw (Lower Set) Oil Holes (2) (one hole at other end of screw) (Models 29 and 30) †
- 145** Distributor Front Screw (Lower Set) Oil Tube (one hole at other end of screw) (Models 29 and 30) †
- 146** Distributor Lower Screw (Lower Set) Oil Holes (2) (one hole at other end of screw) (Models 29 and 30) †

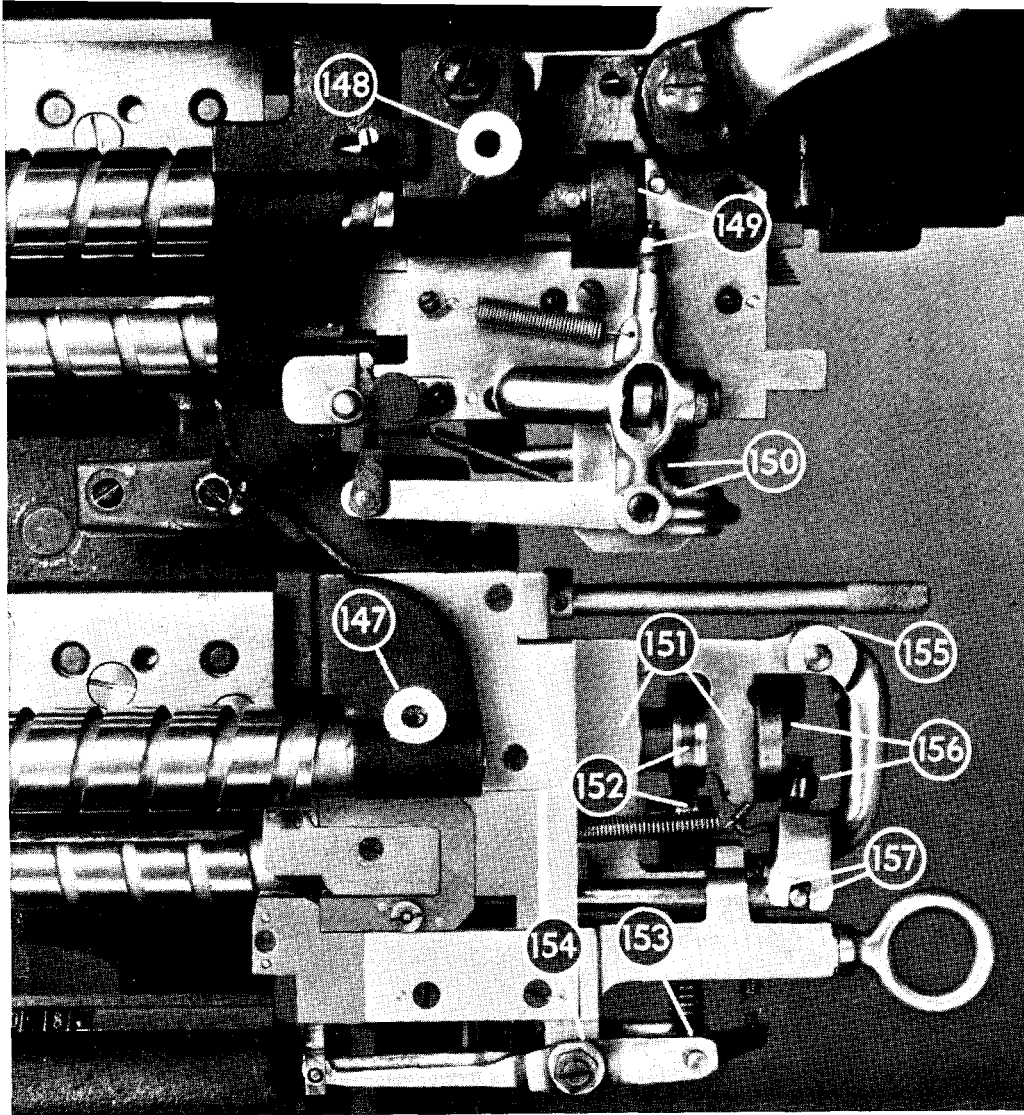

- 147** Distributor Back Screw (Lower Set) Oil Holes (2) (one hole at other end of screw) (Models 29 and 30) †
- 148** Distributor Back Screw (Upper Set) Oil Holes (2) (one hole at other end of screw) (Models 29 and 30) †
- 149** Distributor Box (Upper) Matrix Lift Cam and Roll (Models 29 and 30) †
- 150** Distributor Box (Upper) Matrix Lift Cam Lever Oil Holes (2) (Models 29 and 30) †
- 151** Distributor Box (Lower) Cam Shaft Bearing Oil Holes (2) (holes are in front of box) (Models 29 and 30) †
- 152** Distributor Box (Lower) Matrix Lift Cam and Roll (Models 29 and 30) †
- 153** Distributor Box (Lower) Matrix Lift Lever Oil Hole (Models 29 and 30) †
- 154** Distributor Box Matrix Lift Lever Fulcrum Screws (2) (Models 29 and 30) †
- 155** Distributor Box (Lower) Matrix Pusher Slide Lever Oil Hole (Models 29 and 30) †
- 156** Distributor Box (Lower) Matrix Pusher Slide Lever Cam and Roll (Models 29 and 30) †
- 157** Distributor Box (Lower) Matrix Slide Lever Fulcrum and Pusher Rods (Models 29 and 30) †

### ***Cleanliness and Production***

There are those who may question the need for emphasis being placed upon *Cleanliness* in the maintenance and operation of the Linotype. To such it should be said that a cleanly kept Linotype is a better operating machine for it. Dirt never helps any machine. In a machine which is designed and built to deliver a product whose measurements must be as uniformly accurate as Linotype slugs all dust and dirt should be regularly removed.

Cleanliness is a necessity, if uninterrupted production is expected. A clean, well-maintained Linotype and a clean proof are the measure of craftsmanship.

## **ROUTINE CHECKUPS**

The productive life of mechanical equipment is dependent upon the treatment it is accorded more than upon all other factors combined.

Invariably, serious mechanical troubles are the result of minor items, most of which could have been corrected before they became major difficulties. Linotype servicemen know that most of the causes of mechanical breakdowns could have been averted if the user had maintained a regular schedule of checkups, reasonable cleanliness and proper lubrication.

Hence, this Linotype Maintenance Manual, devoted to conservation of machines and equipment, emphasizes the value of a careful program of main-

tenance. Routine checkups should be as much a part of Linotype operation as seeing that metal is in the metal pot and copy on the copy holder.

A routine program adaptable for small and medium plants is here suggested which should assure satisfactory operating conditions and well-kept equipment.

**DAILY SCHEDULE**

1. Brush metal chips from machine.
2. Clean plunger, well and well holes.
3. Wipe off pot mouthpiece.
4. Wipe off molds and vise jaws.
5. Clean spacebands.
6. Cast slug and check type high and body.

14. Clean distributor screws and oil bearings.

**WEEKLY SCHEDULE**

1. Clean and polish molds and liners.
2. Clean out mouthpiece holes and vents.
3. Clean drippings under pot throat.
4. Check lockup.
5. Oil mold disk slide and grease support screw.
6. Check position of mold wipers; apply graphite on felts if needed.
7. Clean and oil vise assembly; check knife wiper.
8. Brush dirt from keyboard.
9. Graphite assembler and delivery slides.
10. Clean driving pulley and clutch leathers.
11. Clean dust from motor.
12. Wipe off cams and tighten screws.
13. Clean and oil distributor box.

**MONTHLY SCHEDULE**

1. Clean the lugs of one or two fonts of matrices (determined by number and use of fonts).
2. Clean these magazines.
3. Brush escapements thoroughly.
4. Examine assembler star.
5. Examine assembling elevator buffers.
6. Examine assembler slide brakes.
7. Examine keyboard rubber rolls.
8. Examine galley and slug adjuster buffers.
9. Examine ejector blades.
10. Examine distributor box rails, bar point and matrix lift.
11. Clean and oil keyboard.
12. Check vise automatic.
13. Check matrix transfer for proper adjustment.
14. Oil mold turning cam shoe and vise jaw wedge felts.
15. Oil all rollers.
16. Oil all shafts.
17. Fill all grease cups.
18. Clean gas burners.

*NOTE: For location of lubricating points and recommended lubricants, consult the instructions and illustrations on pages 51 through 65. For machine adjustments and mechanical descriptions of functions, see the official Linotype manual, "LINOTYPE MACHINE PRINCIPLES." This is a 487-page completely indexed book which can be procured at any Linotype agency.*



## Schedule for Large Battery of Linotypes

Large batteries of Linotypes, in plants where several machinists are employed, usually receive systematic checkups in addition to normal operating supervision. Quite naturally, there are various methods employed to accomplish these ends and it would be impossible to say that any one system would be best for all plants.

Nevertheless, one of the most effective schedules noted was developed by Alexander Gordon, late Linotype head-machinist of the *Evening Star*, Washington, D. C. This schedule of work which has been published and widely distributed, has been adapted by many large plants to their individual requirements and is printed here for that purpose. It will be noted that the night machinists are responsible for routine repair and maintenance. In addition to this regular schedule any special work which is required to be done on specific machines is indicated in writing, in spaces provided on the blank that is left for the machinists each night. Any comments they may make are written on the reverse of the blank, which thus becomes a report to keep the head machinist informed.

### Machinists' Work Schedule

*NOTE: An afternoon paper; between 40 and 50 Linotypes, with full day crew and varying night force*

#### EVERY DAY

*Before 8 A. M.*

Turn on water.  
Brush metal from machines.  
Clean and oil vises and adjust knife wiper flags.  
Examine gas burners, electric pot rheostats and wipe off pot mouths.  
Put spacebands in machines.  
Clean driving pulleys and distributor shifter buffers.

*Between 8 A. M. and 3 P. M.*

Examine verge springs and rods, keyboard cam rods and channel entrances of magazines.  
Clean all spacebands.

Clean plungers, wells and well holes.  
Skim dross off metal.  
Measure line from each machine for type-high.  
Check and oil Mohr Lino-Saws  
Set temperature of metal.

*After 3 P. M.*

Turn off motors and water.  
Brush metal from machines.  
Clean and oil vises and adjust knife wiper flags.  
Clean out and oil mold disk locking stud blocks.  
Collect and wrap up spacebands.  
Turn off fume pipe exhaust motors.  
Tighten mold cap clamping screws.

The above are *EVERY DAY "MUSTS"*

**MONDAY**

- Clean plungers, wells and well holes.
- Clean spacebands.
- Oil driving pulleys.
- Oil all parts of machines except rollers, distributors, keyboards, assemblers.
- Oil proof presses.
- Oil all other floor motors.
- Dust off and polish magazines.
- Clean assembler entrance covers and glasses.
- Pick up mats from under machines.
- Clean and oil lower bearing Lino-Saw shafts—gasoline ejector plate rod and outer waste rod (half plant).

**TUESDAY**

- Clean plungers, wells and well holes.
- Clean spacebands.
- Wipe off drive wheels and clutches.
- Clean distributor screws, frictions and bearings.
- Graphite line delivery, transfer and distributor slide grooves.
- Wipe off all machines.
- Wipe off cams.
- Blow dust from motors.
- Scrape metal off underside of electric pot throat.
- Clean and oil first and second elevators, parts adjacent and knife wipers.
- Sharpen saw blades.

**WEDNESDAY**

- Clean plungers, wells and well holes.
- Clean spacebands.
- Tighten screw in mold-turning bevel pinions.
- Tighten screws in intermediate shaft bevel gears and pulleys and vise jaw wedge brackets.
- Tighten ejector cam screw.

- Tighten screws on assembler and intermediate clutches.
- Oil distributors, keyboard rollers, assembler boxes and pulleys (half plant). Oil assembler slide rollers.
- Examine machines for adjustments, loose screws, bolts, nuts.
- Oil assembler bearings; clean off matrix delivery belt supporting plates.

**THURSDAY**

- Clean plungers, wells and well holes.
- Clean spacebands.
- Oil driving shafts and motors.
- Oil mold disk and slide.
- Clean bases (half plant).
- Clean assembler entrance covers and glasses.
- Clean and oil saw stands.
- Clean assembler pulleys and front parts of machine.
- Pick up mats from under machines.
- Clean and oil fume pipe motors.
- Measure line from each machine for type-high.

**FRIDAY**

- Clean plungers, wells and well holes.
- Clean spacebands.
- Wipe off cams.
- Oil turnbuckle, second elevator starting spring rod, ejector lever connecting link.
- Graphite assembler slides.
- Clean bases (half plant).
- Oil gas thermostat bearings and arms.
- Oil proof presses and lathe.
- Oil metal feeders (half plant).
- Repair pot mouth wipers.
- Clean and oil spaceband cams.
- Sharpen saw blades.

**SATURDAY**

- Clean plungers, wells and well holes.
- Clean spacebands.

Clean soot from around mouth and pot gas burners.

Dust off machines.

Clean and oil all bright parts.

Clean all commutators.

Clean out inside of metal pots.

Clean and oil mold disk locking stud blocks.

Blow dust from all motors.

Clean delivery slide rods.

Gasoline auxiliary line safety attachment.

#### *Afternoon Shift*

Clean and oil vises, clean spacebands, clean plungers.

New tympan on proof press.

### **SATURDAY NIGHT**

Oil assembler elev. gate roller and pin.

Oil assembler elevator lever shaft (keyboard).

Repair and refurbish wipers and scrapers.

Oil bearings, short line parts, first elevator lever link, wedge bracket and pot lever roller (half plant).

### **SUNDAY**

Clean plungers, wells and well holes.

Clean spacebands.

Clean and repair thermostat contact points and magnet switches in panel boxes of electric pots.

Put on new star wheels where needed, set measures (half plant).

Put on assembling elevator buffers where needed.

### **FIRST WEEK OF EACH MONTH**

Clean and oil vise-locking screws and studs.

Oil universal knife block sections.

Oil spaceband lever pawl hinge pin.

Oil elevator transfer slide link, hinge pins and screw.

Oil delivery slide releasing pawl.

Grease intermediate shaft bevel gears and keyboard roller gears.

Oil delivery slide lever link bearings.

Clean upper keyboard rod guides.

Oil magazine lifting shafts and slides.

Clean bail box and keyboard rods with gasoline.

Grease Lino-Saw transmissions.

Oil belt clamps.

Oil inside del. air cushion cylinders.

Oil all rollers.

Set temperature on recasting pots.

### ***One Machine Each Day***

Clean and repair pot and mouth gas burner.

Face off mouthpiece with carborundum stone.

Ream holes in mouthpiece.

Clean out vents on mouthpiece.

Scrape crucible under mouthpiece.

Clean and oil keyboard cams.

Clean out motor, clean and dress commutator and repair brushes.

Sharpen and set back knife.

Repair knife wiper.

Clean assembler entrance plate and guides.

Clean, oil and repair distributor box.

Repair one set spacebands.

Clean one set mats and magazine.

Examine lower case mats in one machine, take out worn and bad mats and put in good ones.

Clean and polish molds and liners.

Clean driving clutch and leathers.

**Schedule of Night Work**

**MONDAY**

Turn on water for machines.  
 Clean plungers, wells and well holes.  
 Skim dross off metal.  
 Clean all spacebands.  
 Repair two sets of spacebands.  
 Clean and oil lower Lino-Saw ball bearings, clean saw shaft; gasoline ejector, plate rod and outer waste rod (half plant).

---



---

Skim dross off metal.  
 Clean all spacebands.  
 Repair two sets of spacebands.

---



---

**TUESDAY**

Turn on water for machines.  
 Clean plungers, wells and well holes.  
 Skim dross off metal.  
 Clean all spacebands.  
 Clean and oil first and second elevators, and knife wipers.  
 Repair two sets of spacebands.

---



---

**FRIDAY**

Turn on water for machines.  
 Clean plungers, wells and well holes.  
 Skim dross off metal.  
 Clean all spacebands.  
 Repair two sets of spacebands.

---



---

**WEDNESDAY**

Turn on water for machines.  
 Clean plungers, wells and well holes.  
 Skim dross off metal.  
 Clean all spacebands.  
 Repair two sets of spacebands.  
 Clean and oil Lino-Saw wipers.

---



---

**SATURDAY**

Turn on water for machines.  
 Clean plungers, wells and well holes.  
 Skim dross off metal.  
 Clean all spacebands.  
 Repair two sets of spacebands.

---



---

**SUNDAY**

Turn on water for machines.  
 Clean plungers, wells and well holes.  
 Skim dross off metal.  
 Clean all spacebands.  
 Clean thermostat contact points and magnet switches in panel boxes of electric pots.  
 New star wheels and buffers (for half of the plant).

---



---

**THURSDAY**

Turn on water for machines.  
 Clean plungers, wells and well holes.

---



---

---

# ASSEMBLING

---

*Failure of Matrices to Drop*—The keyboard key lever may be “hard” to the touch; the lever may be bent or there may be gum on the sides where it comes in contact with the frame.

Examine the cam yoke and see if it drops down so that the cam rests on the rubber roll when the key is depressed. If it fails to function there may be gum on the sides of the cam yoke where it comes in contact with the frame just over the trigger, which would prevent the yoke from dropping down, or the stop pin may be bent.

If the cam fails to turn after it has dropped on the rubber roll, it may be dry on its pin, the pin broken, the teeth on the cam too smooth, or the rubber roll glazed. If new rubber rolls are put on and are oversize, the cam may not drop low enough to clear the stop pin. If the roll is worn, or undersize, it will not lift the keyboard key rod high enough to give full throw to the escapement lever.

If a matrix has been released by the escapement and comes only partly out of the magazine, it will usually be found that there is rust or gum on the contact points of the escapement lever and the verge plunger, creating a friction that will not allow the escapement to fully open. To correct this, polish contact points or use graphite, but do not use oil. Examine the verge spring and see that it is not too strong, but of sufficient strength to bring the escapement verge back to normal position after the matrix has been released. Also see if the spring is worn where it comes in contact with the escapement verge.

The lugs of the matrices may be bent or burred enough to make them too broad to slide freely in the magazine channel. There may be gum on the matrix lugs or in the magazine channels.

If the lugs of thin matrices are too narrow, these matrices may overlap and wedge fast side by side in the magazine channel.

The escapement pawls may have worn spots at the top and interfere with the matrix when it passes over. This would be particularly noticeable when using thin matrices.

If the lower inside lug of a matrix is sheared off, it will fall into the verge pawl opening and fail to drop. It is also possible that there may be a shortage of matrices in the magazine.

If a thin matrix should fall flat on top of the channel entrance it may cause the matrices which are being distributed to “run wild” and get into the wrong channels of the magazine.

Further information on the care of matrices is given in the chapter, “The Care and Maintenance of Matrices” (Page 41).

**Transpositions**—Unless certain parts of the machine are in correct condition and adjustment, transpositions may occur.

The keyboard cams must have no slippage on the rubber rolls, the magazines and matrices must be clean, and there must be no interference with the assembler entrance partitions. The keyboard rolls, the assembler and matrix delivery belts must run smoothly at full speed; the escapement verge pawls must not hesitate when coming back to normal position after releasing a matrix. The assembler star wheel must not be too badly worn, and the friction spring that pulls the star wheel shaft must be of sufficient strength to carry the matrices evenly into the assembling elevator.

The assembler slide must be kept clean, and the brake spring must be strong enough to prevent the slide from moving too far away from the matrices as they are being assembled.

The assembler chute spring must be adjusted so it will not unduly retard the matrices as they enter the assembling elevator.

The improved chute spring with which all new model machines are equipped needs very little adjustment for various sizes of matrices because it guides the matrices by the lugs instead of the body; but it is very important that the older type of chute spring be correctly adjusted so as not to interfere with the free travel of the matrices.

Care must be taken that oil does not get in the magazine.

After all the foregoing causes of transpositions have been checked, be sure that the assembler entrance partitions are shaped so as not to interfere with the free travel of the matrices into the assembler. The incorrect shape of these partitions is one of the principal causes of transpositions.

**Doublets**—When a keyboard key is depressed, it sometimes happens that more than one matrix will drop. This is generally caused by the failure of the keyboard bar to drop back to normal position to return the trigger under the cam yoke. To correct, remove the entire section of the keyboard bars, place flatwise and remove the two cross banking bars and polish them. Also polish any of the keyboard bars that may have caused trouble and see that the key lever is not bent or gummy on the sides at the front and back end. In some plants gasoline is used on the keyboard key bars to prevent doublets, but this practice does not effect a permanent cure. A rusty hinge rod may cause a trigger to bind.

A broken keyboard cam stop pin would allow the cam to turn continuously, and all the matrices in the magazine channel controlled by the cam would be released from the magazine.

### *The Keyboard*

Keyboard cams should be cleaned and oiled twice a year. To do this, it is necessary to remove both front and back cam yoke frames from the keyboard.

There are three ways to clean the yokes and cams, each depending on the equipment available for doing this work.

The first way is to wash the cams with high test gasoline, after which they should dry thoroughly before oiling; also wash slots where the front end of the cam yoke extends through the cam yoke frame under key reeds.

The second method may be followed if the plant is equipped with a rotary wire brush which can be fastened on the end of a saw arbor. Clean both sides of the cam yoke at each end, and the spot that rests on the trigger; then turn the edge of the cam against the brush so that the brush will clean the teeth and edges of the cam. Also clean the slot as mentioned above.

The third way is to dry clean, provided there is no oil on the cam yokes. Use a very fine file or one that is partly worn (a Barrette file is best) and rub both sides of the cam yoke in such a manner as to remove any accumulation of gum; then scrape clean the outer edge of the cam where it comes in contact with the rubber roll. After the machine has had considerable use, the teeth on the cams are apt to be worn smooth, and to remedy this, hold the cam in the exact position as illustrated below and draw the edge of the file over the teeth in the direction indicated by the illustration, using some pressure on the file. This treatment will make a slight burr on the teeth in the right direc-

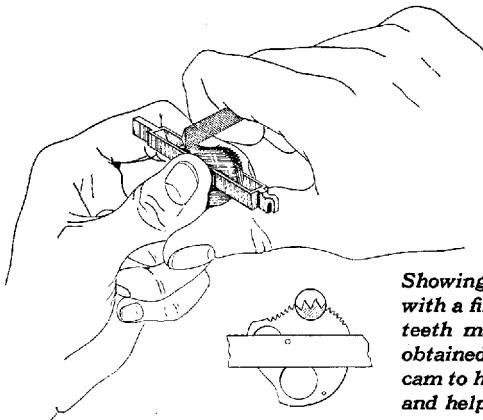

*Showing treatment of worn cam teeth by scraping with a file. The lower view is a cam with two of the teeth magnified to more clearly show the result obtained by scraping. The burred teeth enable the cam to have a more positive grip on the rubber roll and help to avoid transpositions from that source.*

tion to cause the cam to engage on the rubber roll. To file each tooth would be a tedious operation and it would be difficult to get the teeth even, but by **scraping** them the work can be done in a short time without **damaging the cams**. The sides of the slots over the triggers where the cam yokes operate should be scraped. If these slots are gummy the cam might hesitate to drop on the rubber roll. It is good practice to scrape the teeth on the cams no matter what method of cleaning is used.

Before the cams are put back in their frames they should be oiled, using the Linotype Keyboard Cam Oil (X-101). The oil should be applied with a thin wire, flattened at the end, using one drop on the pin on which the cam turns, and spinning the cam to be sure it works freely. All surplus oil should be wiped off before the cam is again placed in the frame.

Before the cam yoke frames are attached to the machine, the keyboard key bars or weights should be thoroughly washed with high test gasoline. They may be taken off as a unit by removing two screws, the heads of which may be seen from the front of the keyboard. When replacing the key bar unit it is necessary to lock the key levers.

*Care of Rubber Rolls*—Keyboard cams should be cleaned and oiled twice a year with Linotype Cam Oil. If the cams do not turn freely the rubber rolls may be damaged.

Do not use oil excessively when oiling rubber roll shaft bearings, as oil is apt to penetrate to the ends of the rubber rolls and damage them. Always wipe surplus oil from the bearings. Use *only* two drops of oil in each bearing.

The surface of rubber rolls should be kept clean and free of graphite and dust. It is advisable to wash them frequently in warm water with a mild soap, such as Ivory. This will remove the hard glaze and prevent slippage of cams.

Do not use gasoline, benzine or any other alkali that tends to cause deterioration of rubber when cleaning rubber rolls.

Be sure to lock the keyboard when the machine is not being used. If a number of keys should be pressed when the machine is not running and then the machine is started, the rubber rolls may be scored.

On machines with the adjustable feature for overthrow of cam yokes, the spring pressure should be checked occasionally as excessive pressure may cause the rubber rolls to wear or to be cut. If the pressure is not sufficient the cams may slip and cause damage to the rolls as well as not actuating the escapement.

Do not roughen rubber rolls by any method.

Do not sharpen keyboard cam teeth to a sharp edge.

On machines that have been used for a long time, the tension of the rubber roll shaft pulley friction spring may weaken. If so, it should be strengthened



or a new spring applied, or else the drive will be retarded by the cam and cause the rubber roll to slip or be cut when the cam is at its high point.

Be sure that the keyboard cam covers are on the machine at all times as they prevent dirt and dust from getting into the cams and yokes. Dirt will cause sluggish action of the cams and unnecessary wear.

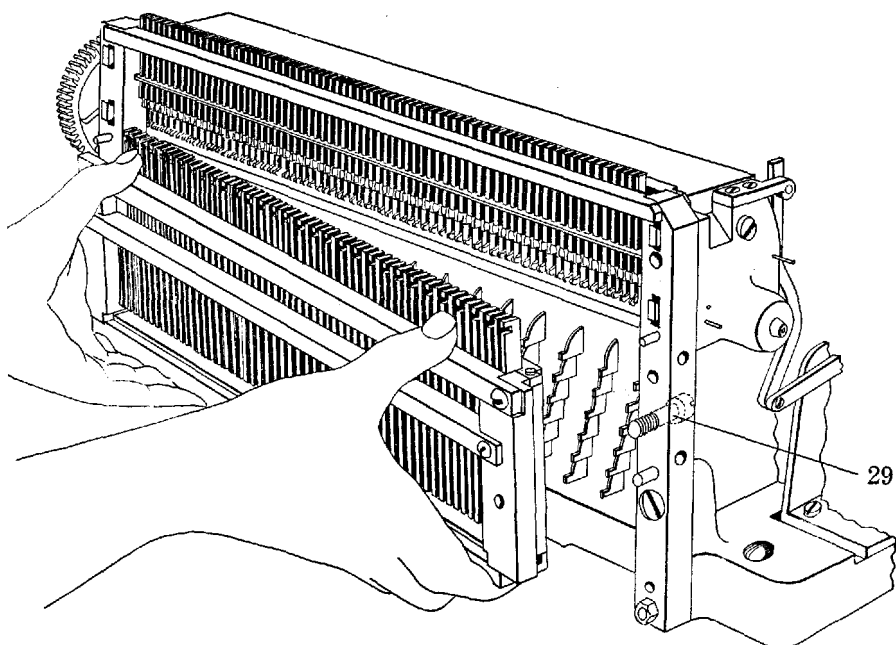

*Showing key bars being removed from keyboard as a unit. Also key bar frame end-piece screws 29, which hold the unit in place.*

When possible, remove old rubber rolls without mutilating them, as some sections can usually be saved to replace other short sections that have become worn. The lower case end of the rubber rolls usually wears out first. To conserve rubber, a short section of a new roll may be used to offset replacement of an entire new rubber roll.

On newer machines there is a knurled collar at the end of the shaft which requires about a  $\frac{1}{4}$  turn to loosen. This must be removed in order to take off the rubber roll. The older machines have a different collar at the end. To remove it drive the oil ring off and take out the pin which holds the collar to the shaft. If the rubber roll sticks to the shaft, it may then be necessary to cut it through lengthwise.

Before applying the new roll, clean the shaft thoroughly, start the roll on the shaft and then place the assembling tool (H-2897), for sale by the Linotype Company, over the roll and stand in a vertical position. With a firm pressure, force the roll over the shaft and stretch the roll so it will be against the collar at each end and uniformly spread over the shaft's length.

If no special tool is available, the roll may be put on by starting one end on the shaft and filling the roll with water. Hold the hand over the top of roll and press down, allowing the water to escape as the roll goes into place.

To replace the rubber rolls into the frames after the cams have been assembled, turn the cam yoke frame upside down, and slide the roll into place. Then turn the frame right side up, and revolve the roll to bring the cams against the stop pins. Tighten the set screws that hold the bushings in place.

*To Clean the Key Levers*—On the right-hand end of the keyboard there is a narrow steel strip about  $4\frac{1}{4}$ " long which is fastened with a small screw at each end. Remove this piece and the rods will be free for removal. Polish the sides of the levers at each end where they pass through the keyboard frame. Do not use emery cloth or other abrasive material. If equipped with a wire brush, use that, or some other polishing agent which will not scratch.

While the key levers are out, clean the slots in the keyboard frame where the key levers pass through, both front and back. If there is any gum on the sides of these slots, the action of the key levers will be sluggish and possibly cause "doublets," as well as affecting the "touch" of the keyboard.

*Re-assembling the Keyboard*—To re-assemble the various parts of the keyboard, begin with the key levers, and it will be easier to do this before the key bar unit is attached. Start with the lower row of keys and work upward.

After the key levers are assembled, lock them in place, and then replace the key bar unit, and fasten the cam yoke frames to the keyboard, doing the back one first. See that the dowel pins enter the brackets and that all of the trigger ends are in place in the key bar slots before tightening the screws that hold the end brackets in place. After the cam yoke frames are tightened, try the rubber roll shaft and see that it spins freely, as it sometimes happens that if the set screws in the bushings are too tight, the shaft will bind. Pull out the upper locking wire, but be careful not to remove the lower one, which is the permanent wire on which the triggers fulcrum.

## Escapements

On all current models of the Linotype with the exception of the Model 9, and Super Display Models, and all auxiliary magazines, the escapements are not attached to the magazines.

The escapement mechanism is mounted on a brass frame, fastened to the

magazine frame with a screw and dowel at each end, and is easily removable from the machine for inspection or repairs.

The escapement consists of a verge fitted with two escapement pawls, an escapement plunger and a verge spring. (See the illustration below.) When the escapement pawl is at its lowest point, the top should be flush with the bottom of the magazine channel so that the matrix will pass over freely.

If the pawls become worn or develop slight indentions at the top, they should be replaced. A verge spring that is worn flat on the bottom may cause

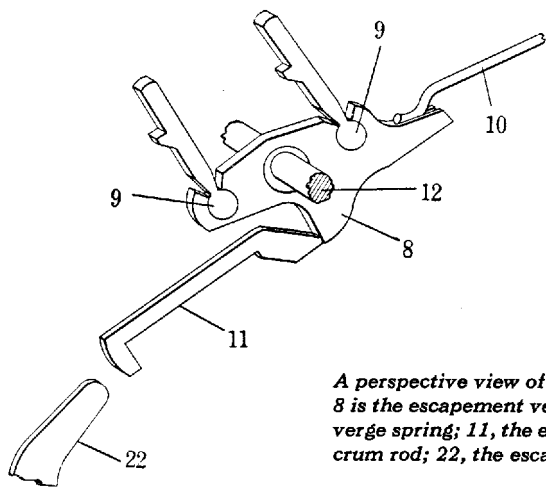

*A perspective view of the working parts of the escapement. 8 is the escapement verge; 9, the escapement pawls; 10, the verge spring; 11, the escapement plunger; 12, the fulcrum rod; 22, the escapement lever.*

enough friction to interfere with the full movement of the verge. If the hole on which the verge fulcrums should become badly worn, there is a possibility that more than one matrix at a time will be released.

The escapements should be thoroughly cleaned once a year. Do not use oil on any part of the escapement. Graphite used sparingly will tend to reduce friction where the escapement levers come in contact with the plungers.

If the escapement has been taken off for repairs, be positive that all verge springs are in place before fastening the escapement guard. When renewing verges and pawls consult parts catalog for proper sizes.

**The Principal Points of Wear Are:** first, the top of the verge pawls 9 where the matrices come in contact with them. After considerable use it will be noticed that a small indention will be made at this point and if worn too much it will interfere with the free travel of the matrices. This is especially true of thin matrices such as the commas, thin spaces, and periods, as these characters are used frequently.

If there is trouble at this point, replace the pawls, and examine the matrices to see that the lugs are not too narrow. If the lugs are too thin, they are apt to get alongside the matrix that is following and wedge fast.

Another source of trouble may be due to friction at the point where plunger 11 comes in contact with the verge 8. If a notch is worn in the verge, the plunger may bind when pushed back, and the spring 10 will not return the pawls to their normal position, or there might be too much friction to allow the pawl to be forced low enough to release the matrix. Also examine the pawl spring 10 to see that the end where it comes in contact with the verge 8 is not worn too flat to slide freely in the groove.

A simple way to temporarily overcome this friction if the wear is not too great, is to take the point of a soft lead pencil and rub it over the front edge of the verge 8 where it comes in contact with the rear end of the plunger 11. This will give it a coating of graphite in its best form and will sometimes last for a long while. The front end of the plunger, where it comes in contact with the escapement lever, may be treated similarly, especially if rust spots show.

When the escapement levers come in contact with the plungers, there is a slight sliding motion, and to reduce the friction, place some graphite on the finger tip and rub over the points of the levers when the lower magazine has been raised to the operating position. Do not use oil on the ends of the plungers as it will eventually get into the verge rack and cause the plungers to bind.

The escapement rack is fastened to the magazine frame by a screw at each end, and is located with dowels. About once a year it should be removed from the machine in order to clean the plunger slots. The plungers are held in place by a brass strip screwed to the escapement rack. After this strip has been taken off, remove the plungers, being careful to keep them in order so that when they are replaced they will be in their original positions.

A rotary wire brush (X-1673 or X-1674) may be used to good advantage for cleaning the plunger slots, and it may also be used for cleaning the grooves on the reverse side of the escapement rack, through which the matrices pass over the escapement pawls. After the plungers have been reassembled, polish the ends that come in contact with the escapement levers.

When necessary to replace an escapement verge, have at hand a rod the exact size of the fulcrum rod 12 (shown in the illustration on page 78). When the fulcrum rod is withdrawn to release the verge, follow up with the other rod, which will hold the verges in place until the fulcrum rod is in position. Before the new verge is put in place, see that it fits freely on the fulcrum rod, and that the verge pawls do not bind in their openings.

When putting in a new verge, the spring 10 should also be replaced, as the end may be worn flat and cause it to bind in the verge groove.

## *The Magazine*

For successful operation the magazine must be clean and free from oil or gum, and there must be no burrs in the channels.

When the magazines are removed from the machine they should be hung in a vertical position on a rack designed for that purpose, and the back cover should be closed to keep out dust or other foreign substance. Graphite should never be used as a lubricant in the magazine. It may help temporarily, but it will eventually cause gum to collect in the magazine and on the matrices.

Before a magazine is removed from the machine the locking bar must be moved to the left as far as it will go in order to lock the magazine and open the safety latch so the magazines may be raised from the escapement.

If the locking bar cannot be moved over it is likely that some of the matrices do not come all the way to the front of the magazine. If so, touch the keys to bring the matrices into position. Never try to remove the top plate of a magazine as it will be difficult to reassemble without special equipment.

When the magazine is placed on a flat surface, the escapement cover, which contains the locking bar, may be removed for cleaning by loosening a screw at each end. Unless the magazine is empty this will expose the first two matrices in each channel and they may be moved back or taken out before the cover is fastened on again.

On each side plate of the magazine there is a  $\frac{1}{4}$ " hole, located about three and three-quarters inches from the front end. If for any reason the magazine does not seat properly on the escapement, and if it is filled with matrices, it may be examined by first inserting a rod through these holes in the sides of the magazine. This rod will hold the matrices back in the magazine with the exception of the first three matrices in each channel, which may be run out; after which the escapement cover can be removed, as before mentioned. This will provide a clear view and make it easy to locate the trouble. If an old magazine is put on a new machine, it is possible that the magazine partitions do not fit in the grooves of the escapement bar casting.

When a magazine is being put on the machine, use care in sliding it back on the frame. If it is slammed back too hard, the matrices are apt to jar back so that the lugs drop through the openings in the bottom of the magazine. This prevents the magazine from seating properly on the escapement.

Before the magazine is lowered to the frame it is well to rub the tips of the fingers across the slots to see that all matrices are in place. If the magazine is not properly seated the matrices are likely to spill on the floor.

While the machine and matrices are new it will be found necessary to brush the magazines quite often, using the regular magazine brush (I-158), until all oil and grit have been removed. The cleaning will then have to be

done less frequently, as by continual use, the magazine channels and matrices will polish themselves unless an excessive amount of oil is used on the machine where it might come in contact with the matrices.

If oil should get in the magazine, wash with alcohol and brush thoroughly, and allow to dry before running the matrices in; but do not wash unless absolutely necessary. Do not use graphite in the magazine or on the matrices, for if they are kept clean it will not be necessary.

### Spacebands

*The spacebands should be cleaned after every eight hours of operation, using graphite sparingly and by rubbing them on a soft white pine board. If metal is allowed to accumulate on the spaceband sleeves it will cause hairlines.*

When replacing the spacebands in their box, see that the sleeves face the right, and also make sure that the bottom of the first spaceband is held by the retaining plate; otherwise the spacebands will either drop too slowly or clog in the spaceband box.

If the spacebands fail to respond properly, the teeth on the spaceband cam may be too smooth or the rubber roll worn, glazed or cut. The spring on the spaceband key rod may not be strong enough to lift the spaceband box pawls to their full height. The pawls may be worn so as to engage more than one spaceband at a time, or they may be blunt on the ends or bind in their grooves (see illustration on page 83). The sleeve on the spaceband may bind near the top, if the band has been bent or burred, and the bottom of the band would not be held by the retaining plate. The retaining plate may be too high to allow the bottom of the band to swing out when lifted by the pawls.

Care should be taken to see that the escapement of the spaceband is operating properly—that the points which separate and lift the spaceband shoulders over the vertically projecting shoulders on the spaceband box are sharp and of equal length, square and not worn, and finally that the lost motion is just enough to give the preceding matrix the proper advantage in the time of its travel to the assembling elevator. This adjustment is particularly important in the rapid operation of the Linotype.

*The Spaceband Box*—Remove it from the machine and examine the pawls 7 for wear. If they are badly worn, they should be replaced with new ones. To obtain a clear view of the pawls, swing the spaceband chute hinge plate 9 out of the way and remove the pawls by loosening the two screws in the pawl spring 2. Both the spring and the long screw extend through the front casting and are connected with the pawl at 14 and 15. Look for wear on the end of the long screw.

If the pawls are in fair condition it may be possible to adjust them back

into shape by following the same course as when fitting new ones, but it might be necessary to use an oilstone on the points to bring them to a sharp edge. If new pawls are to be fitted they should be polished on the sides and must be perfectly straight. The slots where they fit must be clean, and as the pawl levers 1 operate by gravity only, it is plain that there must be no friction.

The pawl springs 2 should have just enough tension to bring them into position when a spaceband is to be used. Too much tension will interfere with the dropping of the pawl levers.

After the new pawls have been connected, see that both points are even when raised to the top, and if there should be a slight difference, examine the pins that hold the levers 1 to the shaft 8, and see that they are tight. The most important detail is to get the pawls fitted so they will be in the correct position when they lift the spaceband. The top points of the pawls shown at 12, should be as far to the left under the spaceband ears as possible, but must not touch the ears of the second band when the first one is lifted. If the points go too far in, they can be brought out by peening the left-hand side near the top of the pawl as shown at 13, to bring it to the proper distance. If the pawl has been spread too much, dress it down with an oilstone or fine file. After the box has been reassembled, raise the lever 1 by hand and see that the pawls drop freely without the slightest friction. The box should then be placed back on the machine and tested.

*Here Are Some Points to Check*—If the spaceband box pawls are known to be correct, and the spacebands fail to work properly, make a simple test in this way: Press down on the pawl lever 1 and allow it to raise very slowly, then see if the bottom of the spaceband clears the detaining plate 6 when the top of the band has been released by the action of the pawls 7.

It may be that some of the bands have worn ears, which would allow them to extend too far down past the detaining plate so that while the spaceband pawls might lift the top, the bottom of the band might not clear the detaining plate enough to allow it to swing outward when the band is lifted.

It is also possible that the detaining plate has been bent forward too far. If this condition is true it may be necessary to grind off a slight amount at the top. This piece is made of hardened steel; use care when bending it to prevent breakage. A new spaceband should be used when making this test.

Another source of trouble might be caused by the spaceband itself if the sleeve should bind at the top of the band, and not go quite all the way to the end; it would be too short to rest against the detaining plate, and would cause the other bands to clog up the chute.

The keyboard rubber roll should be examined for undue wear. If badly worn it would be too small to give enough throw to the spaceband pawls. The

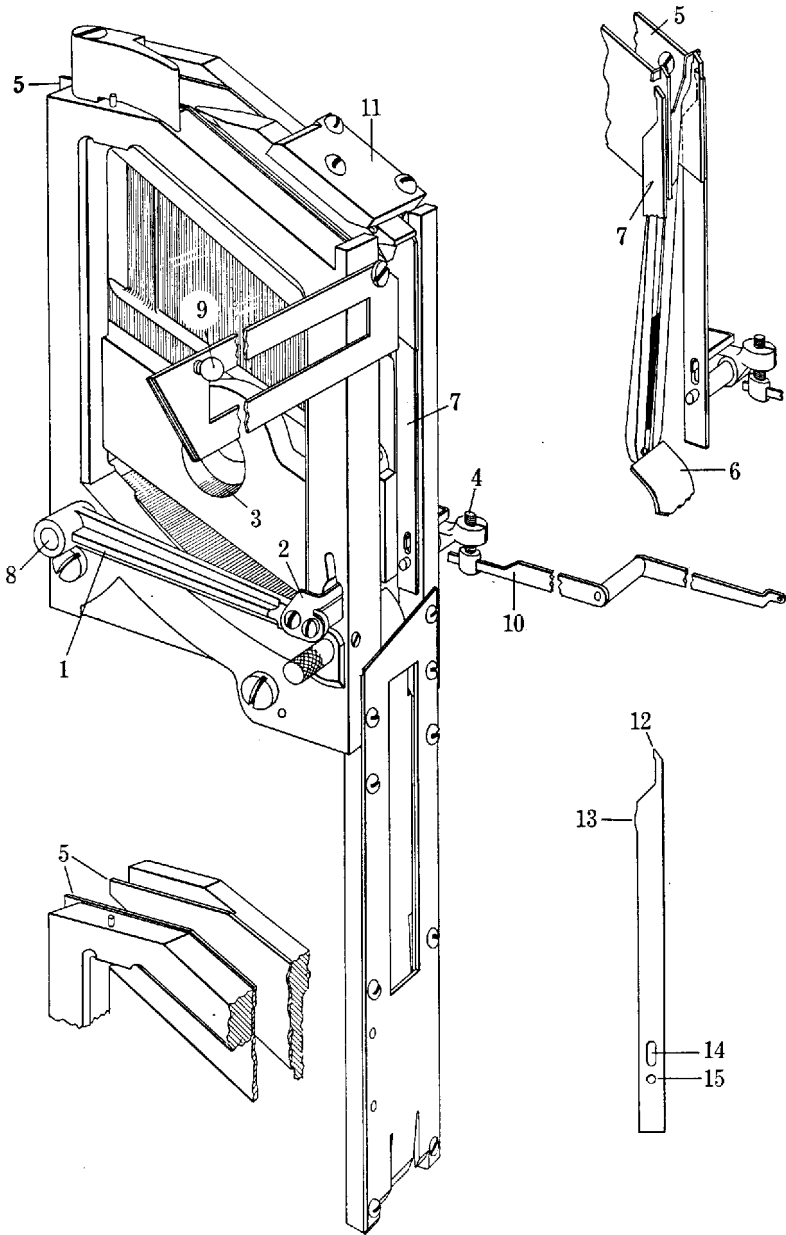

Showing the spaceband box assembled; also separate views of a spaceband resting in normal position; front and back top rails; and a single pawl in detail.



spring on the spaceband rod at the right-hand side of the keyboard should be of sufficient strength to raise the pawls to their full height.

It may be necessary to adjust the stroke of the spaceband pawl levers *1* and a test should be made before starting.

To make this test, remove the keyboard belt, then turn the roll until the cam has moved the front end of the spaceband key lever *10* to its lowest point and see if it allows the pawls to come low enough to engage under the ears of the spacebands on its upward stroke. If this setting is correct, turn the keyboard roll until the spaceband key lever *10* has raised the pawls to their full height. At this point, the pawl lever *1* should be all the way up so that no lost motion can be detected. The key lever adjusting screw *4* must be used to get this proper setting of the stroke of the spaceband pawl levers *1*.

The center plate *11* should be removed occasionally to polish the sides of the upper rails *5* where the spacebands come in contact with them.

The spaceband chute box has an extension not supported on the sides. The function of this extension is to guide the spaceband toward the star wheel. It should be bent in as far as possible, but the opening must be wide enough to allow the bottom of the spaceband to pass through without binding.

Do not use oil on any part of the spaceband box. If the shaft which connects the pawl levers becomes sluggish, take apart and wipe dry; and when replacing, a small amount of graphite may be used in the bearing.

### ***Assembler and Assembler Entrance***

Most transpositions take place at the assembler entrance, but before explaining the causes, it should be made certain that the matrices have not been delayed in their travel up to this point.

The keyboard cams must function properly, the magazine and matrices be clean and the matrices have no burrs on their sides which might make them too broad to pass freely through the magazine channels.

The escapement verges and pawls must not be too badly worn, should be free from gum, and the escapement verge plunger should be straight and should not bind. The partitions or guides should be correctly positioned. If a matrix should strike against the partition at the top, the entire front may be moved either to right or left by loosening two screws at the right end of the upper inclined section of the assembler entrance, and two at the left, one of which holds the assembler entrance cover support. When making this adjustment, it is best to make a mark at the end, so that it can be moved back to its original position if the matrices strike when using another magazine.

The revolving front on the "Two-in-One" machines, is fastened to its shaft with a friction clamp, and if it has been forced out of position, it may be

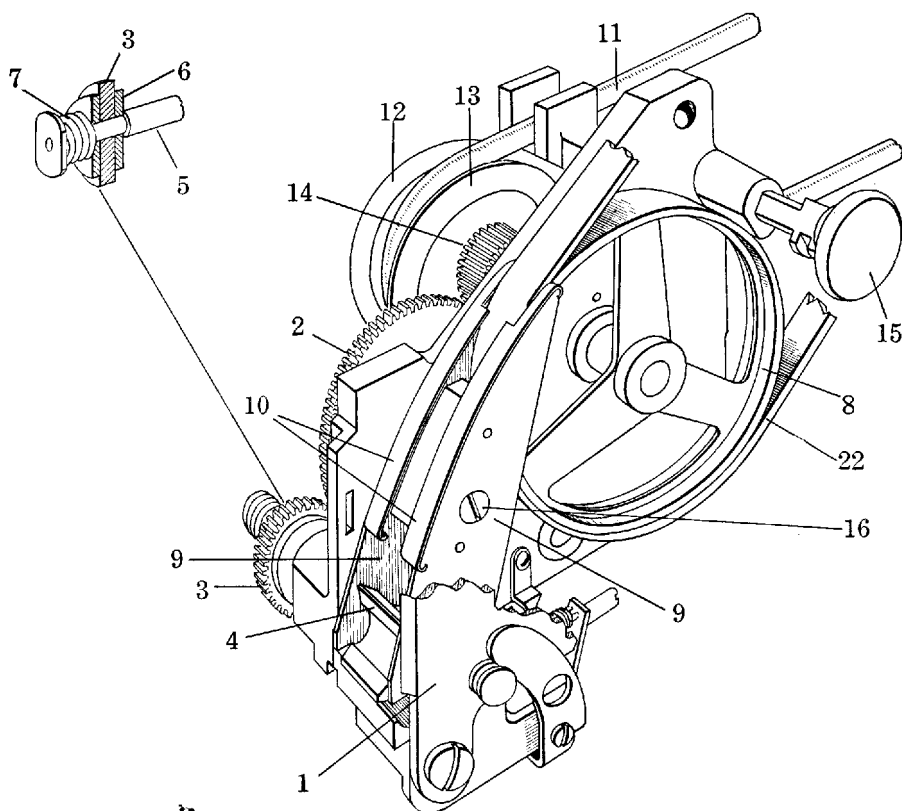

View showing details of the assembler block. The driving pulley shaft has mounted on it at its rear end, an idler pulley 12 and the tight pulley 13, and also the gear 14. The belt 11 may be shifted from the loose to the tight pulley by pulling the knob 15 forward, and vice versa. 2 is an intermediate gear which drives the small gear 3 which is mounted on the shaft upon which the star wheel 4 is mounted. Gear 3 is not tight on the shaft 5, but is held against a friction disk 6 by a spring 7. The friction disk is fastened in the shaft 5. If anything such as a clog of the matrices occurs which stops the action of the star wheel, the shaft 5 stops, while the gear 3 continues to revolve. The slipping action of the gear 3 against the friction disk 6 is to prevent breakage or bending of matrices in such cases. 8 is the large pulley which drives the assembler belt, indicated at 22. 9-9 are the assembler chute rails. 10-10 are the spring rails which are fastened to the fixed rails 9-9. These rails are of such a shape as to direct the matrix directly upon the star wheel. A broken section of the assembler cover is shown at 1.

The front rail is easily detached, for quick change of the star wheel, by removing the screw 16. The back rail and the block, which separates the rails, are both held permanently in place by another screw, back of the screw 16.

turned into place without loosening the clamp screw. If necessary to move to the right or left, two set screws at the right-hand end must be loosened.

See that the assembler chute rail spring *10*, is down tight against the rail *9* (as shown in the illustration on page 85). The top part of the rail spring is cut away to clear the assembler belt. Then the spring widens out and the projection covers the belt. At this point see that the ends are as close as possible to the belt without causing it to bind. This will prevent thin matrices from being caught. Solder the rail springs at the ends if they are replaced.

If the star wheel *4*, becomes worn so that the ears of the matrices are not carried well inside the pawls of the assembling elevator it should be changed. Star wheels are inexpensive, so it is better to change them often rather than adjust the stop screw on the assembler slide to avoid "oversetting."

A small gear *3* is held to the star wheel shaft with a brass friction disk and a strong friction spring *7*. If either of these become too badly worn, there will not be sufficient pull on the star wheel to move the assembler slide evenly. This condition can be overcome by replacing or stretching the spring.

The matrix delivery belt is adjusted for tension by moving the shaft of the idler pulley in the slot. The belt should not be too tight otherwise it will interfere with the free running of the assembler and idler pulley.

The assembler driving belt *11*, should be just tight enough to run the assembler evenly. A jumpy action of the assembler will cause transpositions.

Most of the transpositions take place when the matrices are used from the first few channels of the magazine. So it is important that the shape of the assembler entrance partitions at the lower end be correct. The bottom ends of the first three partitions should be well curved to the left so that when the matrix strikes the assembler belt it will do so at the correct angle.

The adjustment of the chute spring is an important factor in assembling matrices without transpositions, and as the old ones are of various types, they must be adjusted so as not to retard the matrices as they enter the assembling elevator. On all new model machines the chute spring guides the matrices by coming in contact with only the lugs and needs very little adjustment.

Use oil sparingly in each of the oil holes at the back of the assembler belt pulley. There is an oil hole for the star wheel shaft which can be reached when the assembling elevator is raised to expose it. Do not use too much oil. The friction spring at the back end of the star wheel shaft needs some lubrication as well as the loose pulley at the end of the driving shaft. On later models oilite bearings have been used at some points eliminating necessity for manual oiling.

### **Assembler Slide**

To have the assembler slide function properly, the following items should be given careful attention: the brake with the blocks, the brake spring, the return spring, and the brake releasing lever; also check for wear on the assembler slide proper, particularly on its sides where the brake blocks act.

The two brake blocks should have the corners sharp and square where they come in contact with the assembler slide to prevent it from slipping back when the line is being assembled. It must grip tightly enough to overcome the pull of the return spring; otherwise the slide will "chatter." The blocks are made so that when one corner is worn they may be taken off and turned to bring any one of the edges into operating position.

The tension on the brake spring should be just enough to keep the brake blocks against the slide, but not so tight as to interfere with the free assembling of the line. This spring must have tension enough to return the slide when the assembling elevator is raised to its full height, but not strong enough to interfere with the free travel of the matrices as they assemble.

The brake releasing lever has a flat friction spring on the back. This spring should be just strong enough to overcome the pull of the brake spring, so that when a line has been sent in, the blocks remain open until the assembling elevator has seated on the end of the lever. This will allow ample time for the slide to be returned.

If the tension on the brake releasing lever is too strong, it will be harder to trip when the elevator is raised to send in a line, and it will not seat as readily when lowered to the assembling position. It is possible when replacing the friction spring on the releasing lever to give it so much tension that it will force the brake releasing lever so far out it will bind against the assembler slide and interfere with its return.

The adjustment for the return of the assembler slide is made with a screw which banks against the under side of the brake releasing lever, and the distance between should be very slight, to insure the return of the slide.

If the machine has been in use for a long time, the slide may be worn with high and low spots. After the adjustment is made it should be tested. Move the slide slowly the entire length of 30 picas to see if the brake blocks grip at every point of its travel. If there is any slippage, adjust accordingly.

The spaceband buffer should be replaced when badly worn, and the left-hand end of the buffer should be slightly above level rather than too low.

The assembler slide should be cleaned with a dry rag, and no lubricant of any kind should be used. The only part to oil is the shaft of the roll which is under the assembling elevator, and the screw on which the slide return lever moves on some of the older model Linotype machines.

## Assembling Elevator

There are two ways to remove the assembling elevator from the machine when making certain repairs.

The first is to disconnect the link from the assembling elevator lever, then remove the delivery channel by taking out the two screws which hold it, and remove the left-hand gib. The other is to disconnect the link as above, remove the assembler slide, also assembler slide brake operating lever, and the roll bracket. This allows the elevator to be dropped down. By using this method, it will be found when replacing that the elevator will fit exactly as before, because the gibs have not been disturbed from their original position.

If necessary to adjust the releasing pin 10 (see illustration on page 89), it is done with the screw underneath, and to see this screw, it is best to remove the front plate 1 from the elevator.

Start with the pin too low to trip the delivery slide, then raise the elevator until the back rail banks against the stop. Hold in that position and turn up on screw until the delivery slide starts across. With the adjustment made in this manner the latch 9 will be in the proper position to hold the line when transferring. The releasing pin must be straight so that it will come in the center of the starting pin of the delivery slide; otherwise it might not hold the pawl out to clear the second notch when the delivery slide goes across.

On the right-hand end, on the inside of the front plate 1, there is a fiber matrix buffer which should be replaced quite frequently. If allowed to wear too much, the matrices will strike the back rail buffer, which is made of steel and will result in damage to the inside lugs.

When replacing the front buffer it is sometimes necessary to file the face of the fiber at its lower end so that spacebands will pass freely as they are assembled. Also see that the outer edge of the fiber does not interfere with the front end of the assembler block when the elevator is lowered.

On the left-hand end of the duplex rail is the operating finger 8, which moves the aligning piece. See that the point of the finger comes under the projection of the aligning piece on the delivery channel when the duplex rail is pushed in, and it must raise the aligning piece exactly the right height to allow the matrices in the raised position to transfer smoothly. The finger may be bent to bring it to the right position. The distance between the points may be changed by loosening the operating finger and swinging it right or left.

When the machine is new, the distance between the gate and the back rail is right, and a matrix will go between them with a sliding fit; but when the machine has been used for some time the gate and stop pin will gradually wear and allow the gate to go too far in and bind the matrices on the side when the line is being assembled.

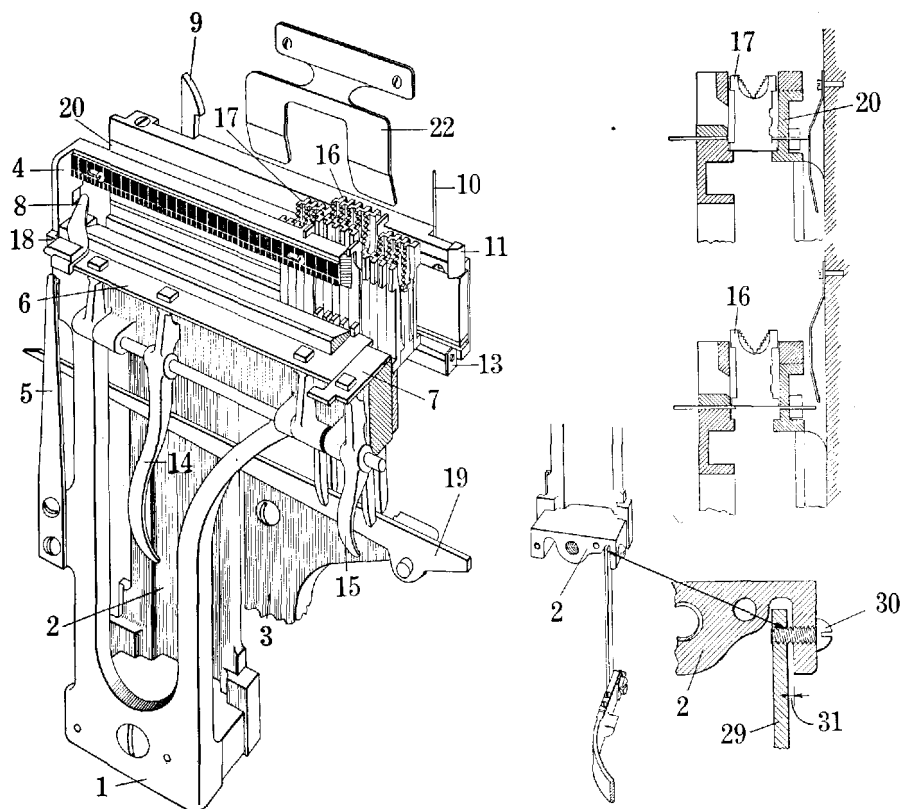

*View of assembling elevator, having a portion of it cut away so as to show the matrices at two different positions in the matter of alignment. The long auxiliary rail may be shifted in or out of use by the lever 14, and the short rail, by the lever 15. It will be noted that the short rail cannot be shifted into use without carrying the long rail in with it; but it can be withdrawn without moving the long rail and can be shifted in or out as desired. Also, the long rail cannot be withdrawn without carrying the short rail out of action with it.*

*At the lower right is shown the clearance space 31, when the link 29 is connected to the assembling elevator.*

The gate rests against a stop pin, and if either or both of these points is peened out it will usually correct the trouble, unless other parts are worn. On the later model machines there will be found a set screw at each end of the gate which may be adjusted to give the right clearance.

At the left-hand end of the gate there is a roll which moves on a pin, and a spring presses against the roll to keep the gate closed.

The pin in the roll should be changed occasionally, for if worn too much, the gate will not close against the stop pin. There is very little wear on the roll, as it is hardened.

When the ends of the rod, on which the gate fulcrums show wear, the rod should be replaced before the holes in the gate become oblong. This rod is fastened with a set screw underneath the right-hand end.

When replacing the lower retaining pawl 13, the screw should force it tight against the upper edge. This will prevent the screw from working loose. The upper retaining pawls 11, seldom need attention.

When replacing the assembling elevator link allow clearance at 31, between the link 29 and the side of the casting of the elevator. The screw 30 runs through a thread in the casting. The hole in the link 29 is also threaded. When connecting, let the screw go about one thread beyond the elevator casting before it enters the link. This distance can best be seen if the front plate of the elevator is removed when the link is connected at the top. On later models, the link 29 is held on the outside of the casting with a shoulder screw.

The weight of the assembling elevator is counterbalanced by a spring which is fastened at the right of the keyboard. One end is connected to the assembling elevator elevating handle, and the other end is fastened to an adjustable hook on the keyboard frame.

A slight amount of oil may be used occasionally on the rod at the end of the gate and on the roll pin.

*Do not use oil where the elevator slides in the gibs.* These parts should be wiped clean frequently, using a dry rag placed on the end of a screwdriver.

### ***Line Delivery Slide***

To operate smoothly, the grooves in which the line delivery slide travels must be kept clean, the air chamber must have the correct adjustment, the friction on the long finger must cause the long finger to "take up" when a short line is sent in. The adjustment of the travel to the right of the line delivery slide is made with the line delivery cam lever split hub on the rear end of the line delivery shaft, and should be adjusted so the short finger of the delivery slide comes just beyond the delivery pawl. The line delivery slide delivery pawl is tripped by a thin steel wire fastened to the assembling elevator. This wire raises the delivery pawl and is adjustable for height with a small set screw underneath the wire bushing.

When the delivery slide moves to the left there is an adjusting screw which should be set so the short finger of the delivery slide will carry the last matrix in a line just inside the first elevator jaw retaining pawls.

If a line of matrices does not enter smoothly into the first elevator jaws, the elevator slide may be too high or too low to register with the delivery channel. The first elevator slide may be gummy and will not settle to its normal position. If so, clean and oil slightly. Also examine the matrix retain-

ing pawls to see that they are in good condition. If a line of matrices in the raised position binds as it enters the first elevator jaw, it may be that one of the matrix retaining pawls is worn; if so, replace both pawls, making sure that the tension is even.

If the movement of the delivery slide is sluggish, rub a small amount of oil, placed on the finger tip, on the face above the grooves where the friction plate of the long finger rests against the face plate.

If the delivery slide travels too far in its return, it will press too hard against the spaceband chute. If a line is sent to the waiting position while another line is being cast, it may not go far enough into the delivery channel to allow the trailer of the delivery slide to trip the latch on the assembling elevator. It will be necessary to wait until the machine is nearly in the normal position before the assembling elevator can be lowered to start the next line.

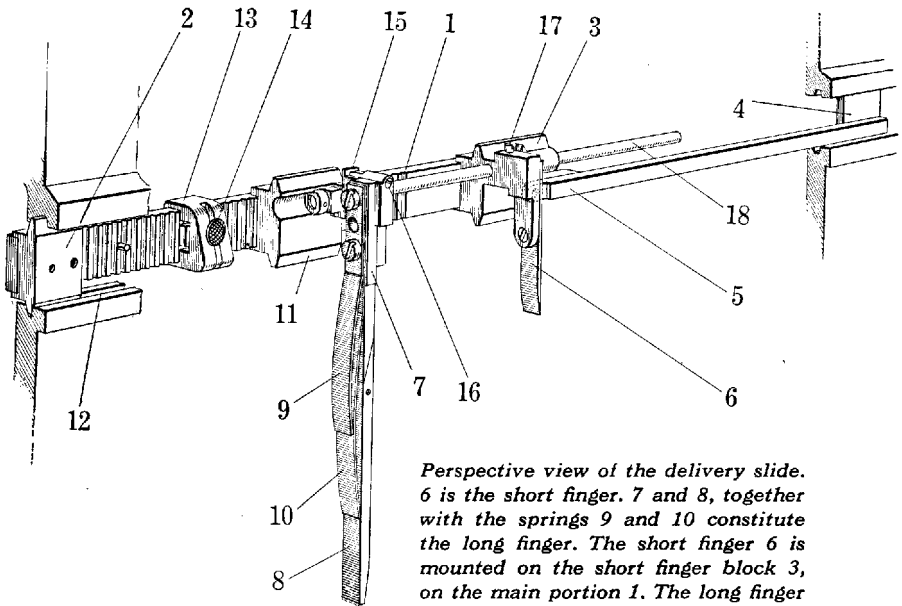

*Perspective view of the delivery slide. 6 is the short finger. 7 and 8, together with the springs 9 and 10 constitute the long finger. The short finger 6 is mounted on the short finger block 3, on the main portion 1. The long finger is mounted on the block 11 which slides on the main portion 1 and is held in place by a spring pressure shoe 15. The block 11 banks against a clamp block 13 which is slidable along 1 and held from movement thereon by a small clamp 14 which fits into notches cut one em apart in the main portion 1. The block 11 has fastened to it, a rod 18 which bears in the short finger block 3 to hold block 11 and the long finger in alignment, aided by spring pressure shoe noted above. The slide block 2 is fixed at the left end of the notched portion 1 and at the right end is the assembling elevator releasing bar, or "trail." This trail, consisting of the bar 5 and the slide 4 to guide it, serves to release the assembling elevator latch at the proper time and also to prevent the latch from hooking up assembling elevator when there is a waiting line in delivery channel.*



Before making the adjustment on the delivery slide, make sure the set-screw which holds the delivery cam to the main shaft is tight. If this set-screw has worked loose it may make a difference in the setting if the cam has shifted slightly; also, if not kept tight, it will cause wear on the key which holds the delivery cam to the main shaft, and if a 30-em line is sent in, the long finger may not be drawn back quickly enough to clear the spacebands on the right-hand side, as the wear on the key would make a slight difference in the timing of the delivery cam.

The adjusting screw which forms the stop for the delivery slide at the left side should be set to allow the short finger to travel  $\frac{1}{3}\frac{3}{4}$ " into the elevator jaws, as mentioned before in this chapter. If not convenient to measure the distance, be sure the short finger carries the last matrix inside the retaining pawls.

When a line has been sent in, and the delivery slide rests against the set-screw on the left-hand side, the delivery lever roll should move the starting pawl just far enough to clear the stopping lever.

If a line is sent in, and the travel of the delivery slide is sluggish as it enters the first elevator jaws, and the starting pawl is moved too far, the machine will start before the last matrix has been caught by the retaining pawls, and the end matrices will fall off.

The long finger on the slide is held in position by a movable block fitted with a ratchet to hold in the grooves of the slide, and when changing to different length lines, the long finger should be brought as close as possible without binding the matrices when the line is delivered. If too much space is allowed, there is a possibility that the matrices may become twisted or badly jumbled if a loose line is sent in.

The long finger must be absolutely straight. It can be tested easily by allowing the slide to go over to the right-hand end of the delivery channel and using that as a square.

A small brass friction plate rests against the face plate, just above the delivery slide groove. It is held by a coil spring and is adjustable for tension by a screw on the outer end. The purpose of this friction plate is to hold the long finger against the line of matrices as it is delivered to the elevator jaws. If a comparatively short line is sent in, the friction must cause the long finger to remain stationary until the line of matrices has carried over and pressed against it, remaining so until the line is completely delivered.

If wear shows on the friction plate and it needs to be replaced, remove the screw which holds the spring, and, with a small screwdriver remove the screw from the plate. This work will be easier if the delivery slide is removed from the machine.

The delivery air cushion cylinder carries a piston, on the top of which is a

leather washer. The top of the cylinder has a vent which can be adjusted to control the speed with which the slide travels.

If the machine is casting a line, and the slide is sent over to the waiting position, the action of the air cushion must be smooth, so as not to jar the long finger away from the matrices. •

The air cushion should be cleaned occasionally in order to insure its continued proper action. Wash the inside of the cylinder and the outside of the piston with gasoline. Dampen the edges of the leather washer with a light oil and set the air vent so the delivery slide will travel without jarring.

*Other Points to Watch Are These*—The guiding rod which is fastened to the long finger block and extends through the short finger block should be kept free from gum, so it will slide freely to allow the long finger to take up the slack when delivering the line.

On the back of the delivery slide bar is a screw, by which the delivery lever link is connected to the slide. To keep it from working loose, there is a small pin that goes all the way through the slide and the end of the screw. When replacing, drive out the pin before attempting to remove the screw. It will be necessary to drill a hole in the screw (from top and bottom of slide for proper alignment of hole) for a new pin after the screw has been tightened.

Examine the stud at the other end of the link where it is attached to the delivery lever, and if worn, replace it with a new one.

The blocks which hold the long and short fingers to the delivery slide may show signs of wear, especially the long finger block, due to the pressure of the friction spring. If allowed to wear too much, the bottom of the long finger will lean so far in it will strike the bottom rail of the assembling elevator when a line is sent away. It is good practice when the blocks are worn to replace both. This will give a better fit to the guiding rod. If the long finger block alone is replaced, the rod must slide freely through the hole in the short finger block, so the long finger can “take up” as mentioned before.

The starting pin should be kept clean so it will immediately drop into position as the delivery slide starts across.

If the movement of the slide is sluggish it can usually be overcome by rubbing a small amount of oil, placed on the finger tip, on the face above the grooves, where the friction plate slides over.

*Do not use oil in the grooves where the delivery slide blocks travel.* The oil may eventually gum up the channels. Keep channels clean and use a small amount of graphite if necessary.

---

# CASTING

---

## *First Elevator Slide and Jaw*

Keep the sides of the elevator slide free from gum and oil them occasionally.

The adjustment for height, to line with the delivery channel, is made by screw in first elevator auxiliary lever, also by turning the barrel of the link at the bottom of the slide. The adjustment to square the elevator jaw is made by four gibs, two upper and two lower. Adjust for height to line with transfer channel by screw on lower right side of slide.

If the face of the type has a poor alignment, examine the matrix adjusting bar and the duplex rail. If worn, replace.

If matrices fall off the line as the first elevator descends to the casting position, examine the matrix retaining pawls. They may be broken, worn, or too weak. If the movement of the line delivery slide is sluggish, the automatic starting pawl may be tripped off before the line is fully in place.

When replacing first elevator back jaw, be sure it is square with the front jaw; otherwise the matrix retaining pawl will not be in correct position, or end of jaw may strike intermediate channel when elevator is rising.

If a matrix falls off the right-hand of the elevator jaw after it leaves the vise jaws it may be due to a broken or worn matrix retaining pawl. If the trouble persists, shut off the machine just as the elevator leaves the vise jaws, and see if the end matrix is held in place, or if it comes against the extended face of the pawl. If found to be in the latter position, the simplest way to correct the trouble is to remove the back pawl and replace it with a slotted one (same as front pawl) and slide it as far as possible to the right, just so it will not bind, and then slide the front pawl out slightly to correspond.

If the line of matrices fails to seat properly between the vise jaws, it may be that the line is too full, or a matrix may have fallen out of the line and be resting on top of the vise cap in such a way as to prevent the line from seating. It is also possible that the back jaw of the first elevator has become bent in such a way as to bind on the vise jaw. A line of matrices that is too tight between the vise jaws must never be forced down, as this practice is apt to

damage the lugs of the matrices. It is always best to raise the first elevator jaw by hand and remove enough matrices to free the line.

On the later model Linotypes the knife wiper is operated from the first elevator slide, and at the top of the slide there is an adjustable plunger which is used to maintain a uniform stroke of the wiper regardless of the thickness of the slug being cast. If this plunger is incorrectly set it will not allow the first elevator to seat properly.

The adjustment to bring the lugs of the matrices to align with the mold groove is made with the center screw in the top of the first elevator slide. The other screw is for adjusting the vise automatic vertical lever so that the mold slide cannot come forward until the center screw rests on the vise cap. If this adjustment is not correct the lugs of the matrices are apt to be sheared off if a tight line is sent in.

*How to Remove a Squirt*—If the squirt takes place in such a manner that the metal holds the first elevator down tight on the vise cap, do not attempt to open the vise until you have first removed the back jaw support. Then remove the wing-pin from the bottom of the connecting link where it is fastened to the first elevator lever. After this is done remove the two screws at the left-hand end of the elevator jaw, then turn the vise locking screws to the open position, and press the jaw apart. At the same time allow the vise to open to the first position, and then pry the line of matrices from the front jaw.

After this is done it usually happens that a long strip of metal has formed between the duplex rail and the matrix adjusting bar and this must be driven out, but do not use a steel tool for this purpose, as the jaw might be damaged. Use a piece of brass, or even a six-point Linotype slug will usually remove it.

After all metal has been removed, try the duplex rail and see that it works freely, and has not been bent. If the rail should bind, it is possible a small piece of metal may be between the duplex rail and the jaw, and it will then be necessary to remove the bottom plate, which is held to the jaw with five screws.

The front jaw is held to the elevator slide with two three-eighths screws and a key to hold it in alignment, and if it becomes necessary to remove it, make a small scratch from the jaw to the elevator head, as it is possible to get a slight variation when replacing, as there are no dowels.

Before replacing the back jaw, take care to see that the lower edge is in exact alignment with the top, using a straight edge, or the edge of a spaceband.

When replacing the back jaw, be sure the two jaws and separating blocks are exactly even at the ends. The long screw goes at the left end, and the shorter one is made to clear the safety plate on the back jaw.

After the elevator jaw has been assembled, try a matrix between the jaws, and see that it slides freely the entire length (30 picas) in both the lower and

upper positions, and also check distance between jaws, to make sure there is not too much clearance. Also try a spaceband in the grooves to see that there is no obstruction.

It is always the safest plan to remove the back jaw on any kind of squirt, as this will leave the front jaw open to inspect for any particles of remaining metal.

When a squirt has been removed from the elevator jaw, examine the left-hand vise jaw to see that it slides freely. It is possible that some metal particles might make it bind.

*Principal Causes of Squirts*—(1) The vise automatic not properly set to throw out the clutch and stop the machine if the first elevator does not seat on the vise cap, which may be caused by some obstruction, or an “overset” line, too wide to go between the vise jaws.

The failure of the automatic to operate may be due to a broken spring in the vise automatic mold disk stop dog, or the spring may be too weak, or clogged with metal.

(2) On machines where the simple two-letter attachment, or “flap” as it is sometimes called, is used, and the machine is not equipped with the auxiliary line safety device, and the “flap” is thrown in place to hold the elevator slide in the raised position, a line assembled with matrices on the upper rail, will cause a squirt since the line of matrices will be doubly raised and the lugs will be too high to enter the mold groove.

(3) As every line set varies in width, the long finger on the line delivery slide must immediately “take up,” or in other words, when the line of matrices starts across, the finger must not start over until the matrices have come against it, and it must stay against them until the line has been transferred to the elevator jaw.

If the long finger does not have this “take up” and the line is sent in just about the time the machine comes to normal position, the matrices are likely to twist sideways, and leave an open space for metal to come through if the line is widely spaced (not full).

(4) Failure of mold disk slide to come ahead far enough to catch the lugs of the matrices. This could be caused by the eccentric screw which controls the slide, working loose.

(5) Particular care should be given to the pot pump stop. The lever which controls this reaches to the end of the right-hand vise jaw, and has an adjusting screw which rests against the jaw and should be adjusted so the stop will just clear the block on the plunger lever, when the line is fully justified. Too much clearance will allow a line that is not quite full to cast, and will possibly cause hairlines. (See “Automatic Pump Stop” on page 116.)

The spring on the pump stop should have sufficient strength to hold the stop under the plunger lever block in case a very short line is sent in as this creates a slight pressure on the right-hand jaw when the justification levers operate, so the spring on the pump stop must be strong enough to overcome this pressure.

Sometimes a slight splash of metal gets under the stop and makes it bind; also on some old machines the plunger lever block comes below the stop so it cannot drop under. Usually this is caused by wear on the pot pump lever cam, a worn cam roll, or roll pin.

*First Elevator Jaws*—The matrix retaining pawls should both have the same amount of tension; this will make a smoother action as the line of matrices enters the elevator jaw, and will be of help when the line of matrices is transferred to the second elevator.

As shown in the illustration just below, the distance between 60 and 61 must be as close as possible without binding the matrix on the sides.

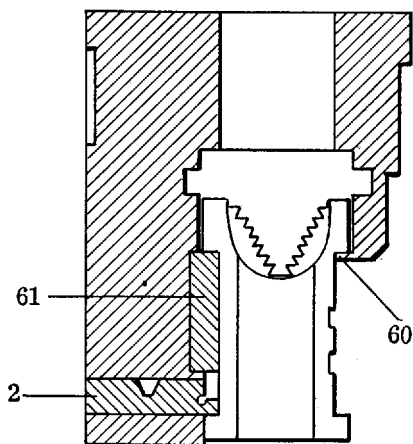

*Cross-section of first elevator jaws. 60 is the lower ledge of the first elevator back jaw; 61 is the matrix adjusting bar on the front jaw; 2 is the duplex rail.*

When the line of matrices goes down in the vise jaws, there is a slight side pressure on the end matrix on the right-hand side, as it comes in contact with the vise jaw, due to pressure of the pot pump stop spring which moves the jaw slightly to the left, and if the matrix fits too loosely between 60 and 61, the lower front lug of the matrix is apt to slide out from under the duplex rail, and raise up enough to cause the lower back lug to be sheared off when the mold advances. This is especially true when the line is fully spaced out.

The diagram shows the top lug of the matrix resting on the matrix adjusting bar 61 and the lower lug under the duplex rail, and this should be a close fit.

If alignment is poor, examine the top of the matrix adjusting bar, and if wear shows at this point, replace it. Or remove the bar, which is held to the front elevator jaw with five screws, and reverse it by turning it inside out. But be sure to taper the edges before replacing it so the matrices will not bind as they enter the elevator jaw. Also examine the under part of the duplex rail for any undue wear at that point.

When the matrices are in the raised position in the elevator jaws, the alignment is held in place by the bottom lug only, and if that part is worn too much, it will be difficult to get a good alignment.

The duplex rail 2 should be examined occasionally to make sure it does not travel too far ahead.

On all late model machines the duplex rail has a small block fastened at each end to control the forward movement of the rail, and these blocks replace the pins which were formerly used for this purpose. The blocks provide a sturdy banking surface and should last indefinitely.

On the older model machines the duplex rail is made with two pins on its lower surface, and these slide in grooves cut in the lower cap, the pins acting as a stop when the springs force it forward.

The duplex rail should be in exact line with face of the matrix adjusting bar. If the stop pins mentioned above should become worn, the rail may come too far forward; and if so, it can be brought back to the proper position by replacing the worn pins with new ones.

*Line Stop*—On all late-model machines the line stop is automatically carried to the right each time a line is transferred to the second elevator.

The tension should be heavy enough to hold the matrices in place, and weak enough so it will not retard a line of matrices when entering the first elevator jaws. Its tension may be increased by widening the open end gap.

The most important function of the line stop is to prevent the matrices from spreading when recasting, and if the matrices are in the raised position in the elevator jaws, to keep the end matrix from falling sideways to the left when the elevator slide is on its upward movement.

*First Elevator Slide Safety Stop Plate*—When using head-letter molds, see that the elevator jaw has a safety stop plate and that there is a stop block at the end of the mold. This safety device throws out the clutch if the “flap” is not thrown into position. Otherwise the line of matrices will be in the lower position in the elevator jaws and the advancing mold will strike the back jaw.

*Elevator Slide*—The elevator slide should be oiled occasionally on the sides where it travels between the gibs. The slide must work freely so its position will be correct to receive the incoming line of matrices. This setting should be slightly below the delivery channel.

The only other part of the elevator slide that needs oil will be the two levers that operate the duplex rail. A small amount of oil rubbed on with the finger tip will be sufficient. Also oil the pins at the ends of the connecting link.

### *The Vise*

When the machine is in normal position the vise may be lowered until it rests against the stop pin, and when in this position the mold slide may be pulled forward part way after disconnecting the ejector lever link and locking the mold cam lever handle down. This will allow ample room for inspecting the pot mouthpiece or the back knife.

If it becomes necessary to open the vise to the second position, turn the machine forward until the first elevator slide rests on the vise cap and stop the machine before the mold slide moves forward. Open the vise to its first position, withdraw the stop pin and lower the vise until the frame again rests on the stop pin which must be back to its normal position. With the machine in this position there will be no strain on the first elevator lever. The vise must never be lowered to either position if the justification levers are raised, or when the machine is near the casting position.

The mold slide can be removed while the vise is open to the second position by locking the mold cam lever handle down and disconnecting the ejector lever link, the ejector blade controller and the water hose.

### *Vise Automatic*

*Setting the Vise Automatic*—First check the center screw in the elevator head to be sure the matrix lugs have the proper .010" clearance (.005" clearance, if Linotype is equipped with a two-letter display mold) in the mold groove, then put the machine in normal position.

Pull out the plunger rod pin for safety, shut off power, and with starting lever out, trip the clutch automatic by hand and turn machine slowly ahead until the elevator slide head center screw just touches the vise cap, and stop turning before the mold slide has started forward. With the machine in this position, with starting lever still out, the exact relation of the stop rod pawl on the automatic stop rod and the point of the vise automatic mold disk stop dog can be clearly seen, and if a close adjustment is wanted on the automatic stop rod, it can be seen just how much room there is between the two points. If the setting is to be made on an old machine, be sure the pawl on the stop rod is tight in its bearing. If loose, tighten it, as this will make a difference in the clearance between the pawl points.

To remove the automatic stop rod, have the machine in normal position with the vise closed, and unhook the end of the spring from the stop rod, then



push the starting lever in and the rod will drop down. To tighten the pawl in the rod, use a hammer and drive back on the split part of the rod just below the pawl. When attaching the rod, see that the pin on the side at the lower end is under the bell crank lever.

Now place a thick matrix on vise cap under the center screw of elevator slide cap and see how far ahead the mold disk dog moves forward before it strikes the pawl on the rod. This distance should be very slight, otherwise if a tight line should be sent in, and the points are too far apart, the action of the clutch throwout would be too late, and the machine would over-run and allow the mold to press against the line of matrices with possible damage.

If everything checks correctly, but the clearance is too much, it may be overcome by bending the stop rod to bring the points closer.

The clutch leathers must be free from grit, and the face of the driving pulley must be clean. The thickness of the clutch leathers makes a difference in the distance between the mold disk stop dog and the automatic stop rod pawl. The thicker the leathers the greater the distance will be between the points, consequently the later the clutch will be thrown out.

### ***Justification***

For proper justification of a line, the spacebands must be clean, the mold must not have accumulation of metal in the grooves or on the face, the matrices and spacebands must slide freely in the first elevator jaws, the center screw in the first elevator slide must be set so the matrices will not bind in the mold groove, the mold slide must not come forward far enough to bind the matrices and vise jaws, the vise justification rods must be kept free from gum and must be well lubricated. The justification bar must be kept free of any substance that might cause the bottom of the spacebands to slip sidewise and cause damage, especially when a line is sent in containing only one spaceband.

*Adjusting the Vise Jaws*—When adjusting the vise jaws to bring the type face to the correct position on the slug, the short jaw is adjusted with the set screw, which is at the top of the knife block. To adjust the long jaw, loosen the clamp screw, and turn the knurled bushing to get the proper setting. When that is correct, be sure to fasten the clamp screw tight so that the bushing will not work loose. The face of the type must come flush with the ends of the slug, especially when “twin” slugs are being set for very wide measure; otherwise, if there is a slight indentation on the slug, a white line will show where the lines join.

*Adjusting the Justification Wedge*—The wedge passes between pieces of felt and these should be oiled frequently to allow the wedge to work smoothly. On the bottom of the wedge there is an adjusting screw, and if it should be

necessary to adjust this, have the machine in normal position and bring the wedge down but not far enough to move the wedge block to the right. This adjustment is not often necessary, but it should be right so that the line of matrices and spacebands is completely unlocked after the cast is made.

*Care of the Justification Rods and Bar*—The top of the justification bar should be kept free from graphite which it may collect from the spacebands. If the bar is too smooth, and there is only one spaceband in the line, the bottom of the band might slide and bend when justification takes place. If the bar is glazed or slippery, rub crosswise with an oilstone to slightly roughen up, *but never grind cross grooves in the bar.*

*Imperfect Justification*—When a machine does not justify perfectly, it may be due to one of several causes, and various tests must be made in order to locate the trouble. First try a matrix in the first elevator jaw and slide it all the way across to see that it does not bind in either the upper or lower positions, then a spaceband in different positions across the jaws to see that it does not bind on the elevator back jaw. Also examine the duplex rail in the first elevator jaw and see that it does not come so far ahead as to cause the matrices or spacebands to bind.

If a line has failed to justify, examine the matrices in that particular line and see if the trouble is caused by a damaged lug binding in the elevator jaw. Also see that the mold does not come too far forward and bind the matrices. The mold slide should be set so that when the pot comes forward the first time, the mold recedes very slightly from the line of matrices when the pot pressure leaves the mold.

Another cause of faulty justification may be an improper setting of the matrix clearance on the first elevator slide which brings the lugs of the matrices in alignment with the mold groove. If enough clearance has not been allowed, the matrices may bind on the upper edge of the groove when justification takes place. The set screw to give the proper clearance is on top of the first elevator-slide, the left-hand one as you face the front of the machine. It sometimes happens that this clearance will differ slightly when the "flap," or simple two-letter attachment, is used to hold the elevator jaws in the raised position. It is possible that some part of the flap has become bent, holding the elevator jaws higher than the proper distance between the regular and upper positions.

If a line has been set that did not justify properly, reset the same line and make a test in the following manner: Remove the plunger pin for safety, then send the line across with the starting lever pushed in. Shut off the power and when the motor has stopped, pull out the starting lever and turn the machine by hand very slowly with the driving pulley until the justification

levers have raised the justification bar, to come in contact with the spacebands for the first justification; then, if the matrices are not spread out against the vise jaws, test each point carefully to see where the trouble lies. As mentioned before, see that the matrices do not bind in the elevator jaws, and that there is the right amount of clearance between the matrix lug and the mold groove. If the line still does not spread easily, use a light bar to raise up on the justification lever, and see if added pressure will spread the line, and if so, it may be necessary to increase the tension of the justification lever spring.

*Lubrication*—The justification rods should be oiled frequently and should not be allowed to become gummy. The rear ends of the justification levers where they fulcrum on the shaft should be oiled regularly.

### *The Mold*

When working around the molds, caution must be used so as not to damage them. The molds should be taken off occasionally to be cleaned, using Dixon's Mold Polish, listed in the Linotype Catalogue as X-1588. This polish will thoroughly clean the molds without damaging them.

When the molds are removed, be careful not to loosen the two lower screws which hold the mold keeper in place. If these screws are loosened by accident, be sure the keeper is tight against the top before the screws are tightened.

Do not use damaged mold liners. If a wrong ejector blade has been used and has bent the liner so it will not come flush with the back of the mold, this opening will allow metal to accumulate on the pot mouthpiece and cause "back squirts." The ends of the liners must be smooth, as a slight accumulation of metal or any roughness will interfere with the ejection of the slugs.

Before replacing the mold on the disk, clean the bearing surfaces of the mold and the disk and fasten with the four screws. To make certain the mold seats properly, turn the screws until they are almost but not quite tight, then fasten the center mold cap screws to bring the mold down on its bearing, and tighten the four mold screws firmly.

If the left-hand liner only is to be changed, it is not necessary to loosen the right-hand mold cap screw, but if the size of the body is to be changed, loosen all three, and when fastening the mold cap down, tighten the two end screws first. If the center screw is tightened first it has a tendency to force the mold cap back, and may cause it to bind on the back knife. This is particularly true when changing liners on a 42-em mold. When ordering liners, it is recommended that they be purchased from the Linotype Company as they are accurately made and have the proper taper of .003". If the taper of the right-hand liner differs from the left, it is difficult to get proper trim on the slug.

Never allow the pot mouthpiece to rest against the mold for any length of time as the excessive heat might draw the temper out of the mold or cause it to become warped.

### Mold Disk and Slide

As the first elevator descends to the casting position, the mold disk makes one-quarter of a turn and it is important that the disk turns freely so that when the mold slide advances, the locking studs in the mold disk will be in line with the stud blocks in the vise frame.

Lack of oil in the mold disk bearing or metal wedged between the back trimming knife and the disk will prevent its free movement. If metal has accumulated between the back knife and the disk it may be because the knife is dull or incorrectly set.

The brake on the mold turning shaft should have just enough tension to prevent the momentum of the disk from carrying the disk too far.

If the mold disk is noisy when it advances, adjust the shoes on the mold turning cam so that when they come in contact with the square blocks on the mold turning pinion, the mold disk locking studs will be in position to enter the stud blocks freely and without noise.

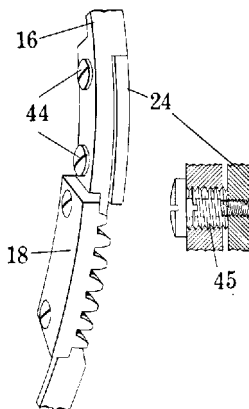

*This is one of the segments of the gear rack which revolve the shaft turning the mold disk. Also shown is the steel shoe which runs alongside the square block and holds the mold disk in position to slide freely on the mold disk locking stud blocks at casting and ejection.*

**Adjustments of the Mold Turning Mechanism**—The mechanism of the mold turning shaft is shown on page 104. The smoothness of the operation of the mold disk depends on the proper setting of the steel shoes 24 in relation to the square block 20. The hardened steel shoe 24 is adjustable by means of a threaded bushing, as shown in the illustration directly above.

When making this adjustment, remove the guard 43, which is fastened to the machine with one screw. Then start the machine and allow the first elevator slide to descend until it rests on the vise cap, and shut off the machine *before* the mold disk has started forward to engage the mold disk locking

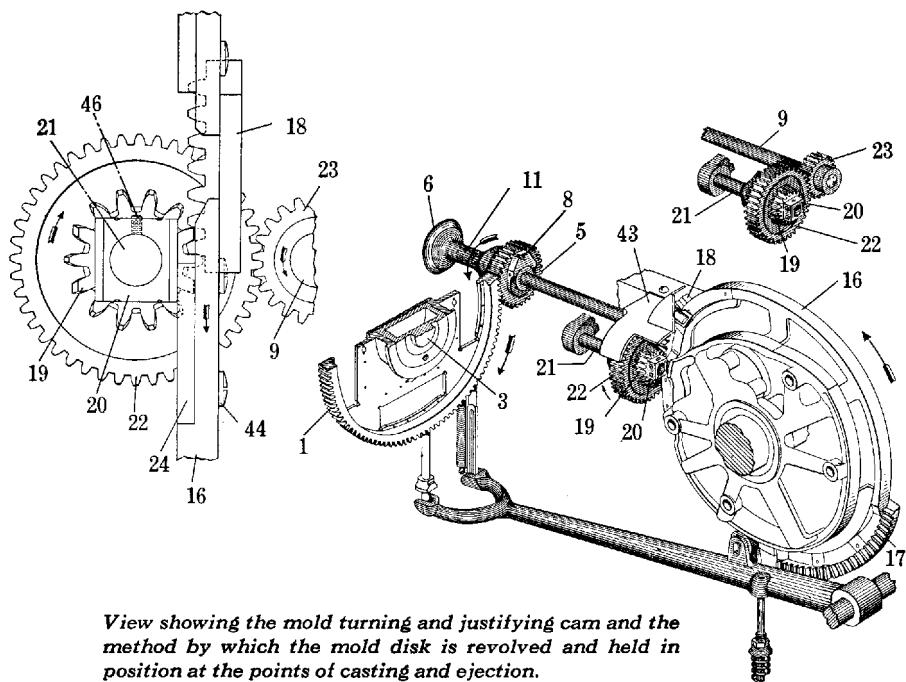

*View showing the mold turning and justifying cam and the method by which the mold disk is revolved and held in position at the points of casting and ejection.*

studs. The steel shoe 24 will then be in contact with the square block 20 and in this position the amount of play between the shoe and the block can be seen when the shaft 9 is rocked backward and forward by hand, using the handle 6 to obtain this motion.

If there is excessive play between these parts, allow the machine to advance to where a screwdriver may be used for removing the screws 44, shown in the illustration on page 103. The screws should be removed one at a time to prevent the shoe 24 from dropping off the cam. After the screw has been removed, turn inward on the screw bushings 45. One complete turn of the bushings will give a movement of .050", so when making the adjustment, only a fraction of a turn should be made before testing. Tighten the screws 44, and, with a micrometer or calipers see that the distance in relation to the outer edge of the cam is the same at both ends of the shoe, then bring the machine to normal position and turn it by hand to see that the shoe does not bind excessively against the square block.

Turn the machine to the ejecting position and examine the shoe and square block at that point, and adjust if necessary in the same manner as described. Several trials may have to be made to get the exact adjustment.

This adjustment must be made properly. When the mold disk is revolving

it must turn far enough ahead to bring the mold disk locking studs in exact line with the stud blocks to advance freely, without noise or bind.

See that the felt, fastened to the side of the guard 43, is kept well oiled.

If necessary to remove the spur pinion 22 from the machine, turn the cam shaft backward until the mold disk comes ahead against the pins, remove the guard 43 and loosen the set screw 46. The machine will now be in position so

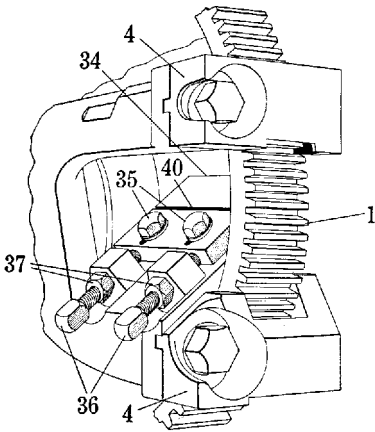

*View of the back trimming knife and the adjusting and clamping screws for bringing the edge of the knife in the correct position against the mold, so that it will trim the bottom of the slug and at the same time will not score the mold.*

that the back end of the shaft may be pried forward slightly to start it and the opposite end will then protrude enough to allow the shaft to be wedged out with a large screwdriver or similar tool. To replace the gear, have the machine with the mold disk ahead on the pins, and this will bring the steel shoe 24 in contact with the square block 20. In this position there will be no possibility of getting the shaft out of time. The square with the set screw 46 must remain at the top as before, and when the gears are correctly meshed, the shaft will go into place easily.

**Adjusting the Back Knife**—The knife which trims the back of the slug as the mold disk revolves past it, should be sharpened frequently to keep the cutting edge in good condition.

If trouble is experienced with slugs that are more than type high (.918"), lower the vise to the first position, disconnect the mold slide and pull the slide forward to clear the small gear. Then remove the back knife 34 shown in the illustration just above, and see if the upper and lower mold disk guides 4, are resting against the front surface of the mold disk. If there is any space between them, loosen the screws and tap them back until there is no lost motion; then turn the mold disk to see that it turns freely, does not bind in the guides, and is properly oiled on its bearing.

When replacing a back knife, loosen the lock nuts 37, and turn out slightly on the adjusting screws 36 until there is sufficient room for the knife between the set screws and the mold disk, then turn the clamping screws 35 nearly tight and have the knife very close but not quite against the mold disk. Rub red lead on the back surface of the mold and turn slowly on the adjusting screws 36 until the knife touches the base and cap of the mold evenly as it is moved past the knife. When setting, if one side of the knife has been brought too close, loosen the adjusting screw 36 on that side and place the point of an iron-handled screwdriver in the slot 40 of the knife and drive down toward the adjusting screw without loosening the clamping screws. When properly adjusted, tighten the clamping screws. Hold the heads of the adjusting screws with a pair of pliers or a small wrench so that they will not move and disrupt the adjustment when the lock nuts are tightened.

The proper setting of the back knife is very important. It must be close enough to trim the slug type high, and the disk must turn freely when the operator changes molds. If the disk turns hard, the locking studs will not align properly to enter the stud blocks when the mold slide advances.

*Sharpening the Back Knife*—If the cutting edge of the back knife is nicked or very dull, it should be sent to the Linotype Company to be properly ground. Always have a sharpened knife on hand ready for use at all times.

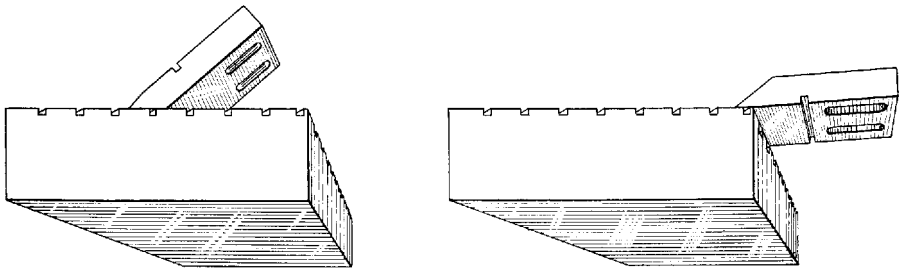

*Showing correct procedure in sharpening the back knife.*

If the knife is not neglected too long, it is possible to maintain a good cutting edge by removing the knife from the machine and dressing the edge in the following manner: Use the lapping block, part number F-317, which can be obtained from the Linotype Company. Sprinkle the surface with No. 120 emery powder, X-491, also available from the Linotype Company; then moisten with kerosene.

Holding the knife in the position shown to the left in the illustration on this page, rub over the surface of the lapping block. Then holding knife as shown to the right, rub lightly until a sharp, even edge has been obtained.

It is important that the original bevel of the cutting edge is not changed, and care must be taken to hold the knife against the lapping block in such a way that this cannot happen. The condition of the back of the slugs will indicate the necessity for the above treatment of the back knife.

*Adjusting the Movement of the Mold Slide*—To adjust the mold slide so that there is proper clearance between the face of mold and matrices when justification takes place, the mold cam roll eccentric pin 92 (in the illustration on page 108), must be adjusted when the mold cam roll 91 is on the section of the mold slide cam shown at 83 which is the highest point of the cam. When the eccentric pin is properly adjusted the space between the face of the mold and the vise jaws or matrices should not be less than .003" or over .005". Adjusting the eccentric pin handle toward the rear of the machine moves the mold slide forward; adjusting the handle toward the front of the machine moves the mold slide backward. This setting is extremely important and if improperly made will result in trouble in justification.

Before making the adjustment of the eccentric pin it will be necessary to release the pressure of the pot lever spring. This is done by removing lock nuts 84 and 85, wing pin 86 and eyebolt 87. Never disturb lock nuts 89 and 90.

This adjustment of the eccentric pin is made as follows: Remove the first elevator back jaw and also remove the line stop. Close the left-hand vise jaw and run the machine around until the first elevator rests upon the vise cap. Place a strip of ordinary newspaper (measuring .003" thick) between the vise jaw and the face of the mold. Then move the machine ahead until the mold cam roll is on the section of the mold cam at 83. With the machine in this position, there should be a slight resistance when the paper is pulled from between the vise jaw and the mold.

When the proper adjustment has been obtained, the eccentric pin lock nut must then be turned very tight so that the eccentric pin will not slip, and while it is being tightened it may be necessary to hold the handle with a small wrench or a piece of pipe to keep the eccentric pin from changing its position.

After completing the setting of the mold slide, allow the machine to complete its revolution. Then replace the first elevator back jaw, being careful to put the screws back in their correct positions, as the one screw is somewhat longer and will extend through the jaw and damage the safety plate if their position is reversed. Also replace the line stop.

When the jaw and line stop have been replaced, allow the machine to run ahead until the first elevator rests upon the vise cap. With the machine in this position, the pot lever spring can again be connected. Then run the machine ahead to the casting position and make sure the space between the pot lever and the lock nut is approximately  $\frac{3}{16}$ " as shown on page 108.



When the mold slide is in normal position, it is supported on the left-hand side by a support screw. This support screw seldom needs attention, but after considerable use it may become worn too much to support the mold slide properly. To adjust this screw, have the mold slide in normal position and

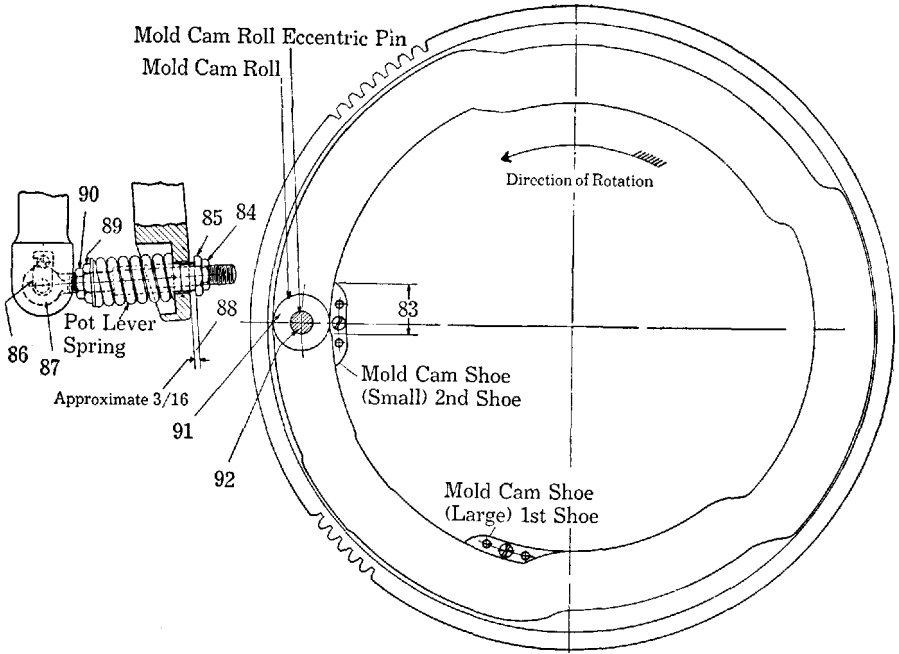

*View of the mold cam and driving gear when standing at right-hand side of machines, showing the mold cam roll and eccentric pin.*

remove one mold from the disk and turn the opening to the ejecting position which will expose to view the mold slide; then raise up on the mold disk guide and insert a strip of paper between the lower right-hand side of the mold slide and the column of the machine. After loosening the support screw lock nut, turn the support screw up until the paper can be withdrawn, and then tighten the lock nut.

**Adjusting Mold Disk Locking Stud Block**—When the locking studs and stud blocks become too much worn it will be almost impossible to trim the slugs parallel, and it may be necessary to replace the locking studs and the stud blocks. The stud blocks are doweled to the vise frame, and when new blocks are put on, the dowels will generally bring them to the right position as they are made interchangeable. After the new locking studs and stud blocks have been fastened in place they should be tested. To do this, disconnect the

mold slide and pull the disk forward on the locking studs to see that they do not bind, and also see that the ejector blade is in line with the base of the mold when the blade comes forward. If the blade does strike, or the locking studs bind in the stud block, it may be necessary to remove the dowel pins from the blocks and fasten them loosely to the vise frame; then see that the ejector blade is correct in relation to the mold. Tighten the stud blocks evenly so that the locking studs will be free in the blocks.

The locking studs are fastened to the mold disk with a screw in the back which passes through a keeper, and should be examined occasionally to see that the screws have not worked loose.

*Removing the Mold Slide*—Run the machine ahead until the first elevator rests upon the vise cap, stop the machine by pushing back the starting and stopping lever and then shut off the power. Remove the pot pump plunger pin and the ejector lever link; lower the mold cam lever handle; remove the ejector blade controller link rod, and the controller. Open the vise to first position; raise the first elevator slide by hand, and lower the vise to a horizontal position. Detach the hose from the mold disk stud, first turning off the water, and the mold slide is then free to be removed bodily from the machine.

### ***Mold Wipers***

The back mold wiper is for the purpose of keeping the back of the molds free from metal accumulation, and should be adjusted so it will rest against the mold disk when the machine is in normal position. The felt on the wiper should occasionally be rubbed with dry graphite. If oil is used, it is apt to come through the mold and foul the matrices, eventually causing hairlines.

The felt on the front mold wiper should bear against the face of the molds when the mold disk turns. The felt on this mold wiper also should be occasionally rubbed with graphite.

### ***Metal Pot***

The product of the machine depends largely on the care and adjustment of the metal pot. The pot legs must be adjusted to bring the mouthpiece in alignment with the mold, otherwise the machine is apt to "back squirt." Other causes of back squirts are damaged mold liners, a broken or weak pot lever spring, improper adjustment of the pot lever, metal on the back of the mold, the metal temperature too high or too low, or a foul plunger which "jumps" just before it descends and forces metal between the mouthpiece and the mold to prevent a good lockup. The metal temperature should be checked with a special thermometer which may be obtained from the Linotype Company and is listed in the Linotype Catalogue as X-1480.

To obtain a solid slug with a clear face the metal must be of standard quality, the holes in the mouthpiece must be fully open, the vents in the mouthpiece must be sufficient to allow the air to escape from the mold, the pot plunger spring must not be too weak, the holes in the sides of the pot well must be kept open, and the metal in the pot must be kept at the proper level.

It is difficult to get a solid slug if the plunger is worn enough to allow metal to escape around the sides of the well when it descends, or if the vent in the bottom of the plunger is open too much. If the plunger is badly worn, replace with a new one of standard size, but if the pot well is worn, it may be necessary to install an oversize plunger. Oversize plungers are obtainable from the Linotype Company and will be furnished .005, .010, or .015" oversize as specified with the order.

It seldom happens, but it is possible for a plunger to stick in the well at the bottom of its stroke. If this does happen, push in the starting lever and withdraw the plunger pin; then allow the machine to come to normal position so that the pot mouthpiece will not rest against the mold. Dip metal from the pot until the well is exposed, then put some tallow or oil on the top of the stuck plunger and allow it to soak in. Grip the plunger rod with a monkey wrench and try to rock it from side to side; at the same time, with a light hammer tap the top of the plunger rod. Work the plunger upward slowly with a rotary movement and when it is removed both the well and the plunger should be cleaned thoroughly.

If the plunger is exceptionally hard to remove, additional leverage may be obtained in the following manner: Use a  $\frac{3}{8}$ " bolt about two inches long with two nuts. Fasten the bolt in the plunger rod opening, one nut on each side, then use a length of pipe with the end over the bolt head and place some blocking on the outer edge of the pot underneath the pipe. Then use the pipe as a lever to pry upward on the plunger rod. Grip the plunger rod with a monkey wrench and turn from side to side while the rod is being pried upward.

It is a custom in many printing plants to clean the plungers daily, and this rule should be observed while the machine is new, but after continued use the plunger and well may become slightly worn and it may not be necessary to clean so often. Watch the plunger as it descends, and if it has a continued downward movement to the bottom of the well, it will not be necessary to clean every day. If a plunger fits loosely in the well, daily cleaning would be a detriment rather than a help.

*The Pot Mouthpiece*—The vents in the mouthpiece are for the purpose of allowing the air to escape when the plunger is forcing metal into the mold, and they should be quite broad, with a small opening at the lower end. Scrape the vents occasionally to remove any accumulation of dross. The opening at

the bottom of the vent should show a slight drip of metal at each cast and the amount of vent can be seen at the back of the mold if the machine is shut off just before the slug reaches the back knife.

A scraper for the vents can be made by grinding the end of a file to a V-shape. Always scrape the vents toward the bottom of the mouthpiece.

After the machine has been used for some time, the holes in the mouthpiece should be reamed slightly at the front end where the mouthpiece comes in contact with the mold. This will remove any burrs or dross deposits that may have formed, so that when the pot breaks away from the mold, the metal will adhere to the base of the slug instead of staying in the mouthpiece holes, and also when casting a slug of thin body size, the pot will break away from the mold much easier if the holes are reamed.

If no reamer is available, a small three-cornered file, with the end ground to give it an edge, will serve the purpose. The holes must not be enlarged: the reaming must be just enough to remove the burr. If the holes in the mouthpiece become clogged, drill out with a No. 52 drill. The holes in the mouthpiece have a slight taper; the original measurement is about .062" at the back and .070" at the front.

If it becomes necessary to remove the mouthpiece, use a pot mouthpiece screw loosener, listed in the Linotype Catalogue as F-2860. Place the tongue of the loosener in the screw slot and with a hammer give it two or three raps against the screw head to ease it from its seat. Then with a heavy screwdriver fitting closely in the screw slot, press firmly against the screw and give a quick snap to the screwdriver, which should loosen the screws.

Before replacing the mouthpiece, clean the surface of the crucible and the back of the mouthpiece—a fine oilstone having a straight surface or a piece of fine emery cloth placed on a block of wood may be used on the crucible. For the mouthpiece use emery cloth placed on a flat surface and rub until bearing shows evenly all around the mouth of the crucible.

If the throat of the pot has become fouled with hardened dross, it can be removed with a pot throat cleaner, listed in the Linotype Catalogue as F-4236.

When the mouthpiece is ready to be fastened in place, spread a small amount of heavy oil over the surface (do not use red lead on the back of the mouthpiece or on the screws), and tighten the screws evenly.

*Testing the Lock-up*—When the machine leaves the factory, the pot legs are adjusted to bring the mouthpiece in perfect alignment with the molds, but after the machine is in daily use, the continuous heat may cause certain parts to warp, and cause a poor lock-up, making it necessary to adjust the pot legs.

To make this test, open the vise to the first position, disconnect the mold slide and pull the mold disk forward. Then clean the surface of the mouth-

piece by rubbing very lightly with a fine oilstone that has a straight surface, and also see that the back of the mold is clean. Then mix some powdered red lead with oil to make a paste and with a rag, cover the back of the mold with a light coating of the mixture. Push the mold slide back to normal position, with the mold that has been red-leaded at the top of the disk directly in front of the mouthpiece. Close the vise and remove the pot pump plunger pin.

When making the lock-up, test in this manner: The mold disk must remain stationary until the machine has made a complete revolution to the normal position. To accomplish this, pull forward on the mold disk pinion until it is out of mesh with the pin in the flange of the mold turning shaft, then pull the starting lever. With the handle, hold the pinion out and keep it steady so that when the mold disk advances the locking studs and blocks will line up.

The pinion must be held fully out until the machine has come to the normal position, otherwise, if the mold disk was allowed to turn, the back knife would scrape the red lead from the back of the mold.

After the machine has completed its revolution, lower the vise, pull the mold slide forward so that the mouthpiece may be examined. The red lead now adhering to the mouthpiece will show how it aligns with the mold. If one end of the mouthpiece does not show any red lead, adjust that side forward or the opposite end backward, using the screws in the pot legs.

To bring the left-hand end of the mouthpiece forward, release the lock nuts, loosen the rear screws and tighten the front screws. Only a fraction of a turn should be made on these screws before making another test. When making these tests it should also be noted if the mouthpiece has the same bearing at the top and bottom. If the mouthpiece does not show a good bearing at the bottom, loosen the back screws on both pot legs as evenly as possible (the number of turns on the screws depending on how much the mouthpiece is out of line with the molds), and then tighten the front screws. Reverse this process if the bearing appears light at the top. Bring screws just against the pot leg bearings (not too tight) and fasten lock nuts. After the pot legs have been adjusted as closely as possible, the mouthpiece may show some high spots and it may be necessary to true it up with an oilstone. When making these tests the ejector blade should be set to the shortest width to prevent the blade from striking a mold liner.

The power lock-up as given above can safely be used when it is known that the alignment is only slightly off, but if a new pot and crucible are to be installed it is well to use the hand lock-up first to bring the mouthpiece in line with the back of the mold. This is done in the following manner: Turn the machine ahead until the first elevator slide rests on the vise cap. Then open the vise, disconnect the mold slide by removing the ejector lever link and pressing

down on the handle of the mold cam lever, then pull forward on the mold slide. See that the back of the mold and the mouthpiece are both clean, then with a rag cover the back of the mold with a thin coating of red lead paste; push the mold slide back and see that the disk is properly meshed with the small driving pinion. Close the vise and push the left-hand vise jaw to the right. Then pull the mold slide forward onto the locating studs with a thin bar placed between the pot lever and the bracket. Force the pot all the way ahead two or three times to bring the red lead on the mold in contact with the mouthpiece. Then push the mold slide away from the locating studs, open the vise,

pull forward on the mold slide and examine the mouthpiece. If the red lead does not show evenly all the way across, adjust the pot legs in the same manner as previously described, until the mouthpiece is in correct alignment with the mold. It may be necessary to repeat the above operation to obtain a satisfactory lock-up.

The holes in the mouthpiece should come just above the base of the mold and the holes at each end must not be covered. This adjustment is made with the screws on top and bottom of pot legs.

*The Pot Pump Plunger*—The metal pot pump plunger should move up and down freely within the pot well but should fit closely enough to prevent any leakage of metal between these parts. The plunger must be kept clean so that when casting a line it will continue steadily on its downward stroke until it is raised by the cam. If it does not complete its full stroke a ring of dross may have accumulated in the well and it must be cleaned out.

On the bottom of the pot pump plunger (see illustration on this page) there is a lock nut 45 and a hexagon-head adjusting screw 46 with a hole drilled across the body in line with the vent hole 47 which is drilled horizontally across the projection at the bottom of the plunger. There is a hole drilled through the bottom of the plunger to meet this opening.

To adjust the size of the opening 47, loosen the lock nut 45 and turn the screw 46 until the vent is the desired size.

When setting the smaller size slugs, the vent acts as a relief valve to let excess metal escape upward through the plunger. Thus the plunger goes deeper into the well and prevents dross from collecting on the plunger and the sides of the well. In most cases the vent should be set to have the opening wide enough to insert a  $\frac{1}{16}$ " wire. If too much vent is given, the plunger will not have enough force to fill the mold when casting the larger size slugs.

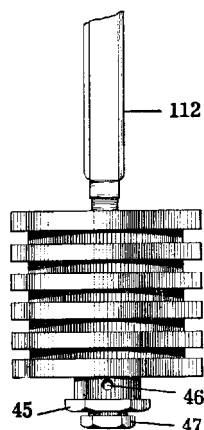

Showing details of pot pump plunger vent adjustment. 45 is the vent adjusting screw lock nut; 46, adjusting screw; 47, vent hole; 112, plunger rod sleeve.

The plunger rod sleeve 112 acts as an insulator to prevent the accumulation of metal on the plunger rod. The sleeve is tightly fitted at the ends while the center section is expanded to form an air space.

A foul plunger may bind at the top of the well and not allow the pot lever roll to drop against the cam after a slug has been cast, which would leave the pot ahead of its normal position, and the holes in the side of the well would be covered by the plunger, resulting in hollow slugs.

The holes in the sides of the well must be kept fully open to allow the metal to flow under the plunger when the machine is in normal position. A pot mouth wiper, F-304, is usually furnished with the machine and a hook on this wiper is used to open the holes.

The level of the metal in the pot should be maintained as evenly as possible, about  $\frac{1}{2}$ " below the top rim of the crucible. Various types of metal feeders are available to keep the metal at the proper level continuously.

*Back Squirts*—A splashing of metal over the back of the mold disk is called a "back squirt" and may happen for various reasons.

The first thing to test when a back squirt occurs, is the lockup of the mouthpiece against the mold in the manner described previously.

Causes of back squirts are: metal in pot too hot or too "cold;" mouthpiece overheated, or not hot enough to keep the metal from chilling on its surface. The compression spring, shown in the illustration on page 108, may be broken or too weak, or the adjustment may be wrong between the pot lever and the shoulder nut 85—the clearance should be  $\frac{3}{16}$ " to give the spring the proper compression when the pot is locked against the mold.

It is also possible that one of the anti-friction rolls in the pot cam roll may be broken. If it is necessary to remove the pot lever, take out the wing pin 86, which holds the eyebolt 87 at its front end. At the top, the pot lever is held by a rod which extends through two lugs at the back of the pot jacket. To disconnect it, loosen the set screw and remove the rod. Then the pot lever can be taken out without disturbing the adjustment of the compression spring.

At the first sign of a back squirt, push the starting lever in to shut off the machine, and if there is not too much metal behind the disk, lower the vise and pull out on the handle of the mold turning pinion and try to turn the mold disk backward to move the metal away from the back knife. Then disconnect the mold slide and pull the disk forward and with a steel hook and a screwdriver, scrape the metal loose, being careful not to damage the molds. If the metal has wedged the mold disk tight, it may be necessary to pry it backward far enough to free the metal so it can be scraped out. After the metal has been removed, clean the mouthpiece with a rag, and examine the inside rim of the mold disk to make sure that no metal particles remain. Push

the mold slide into place, having the small pinion and the mold disk in mesh so that the spots will be opposite to each other when the machine is turned to normal position.

*Pot Pump Lever Retaining Rod*—The retaining rod, when properly adjusted, eliminates wear on the pot pump cam. Adjustment of the retaining rod, introduced on late model machines, is obtained by revolving the cams manually until the pot pump lever roll rests on the high point of the pot pump cam shoe (short), then adjust the retaining rod support screw until it just clears the bottom of the retaining rod. The retaining rod support screw is located in the bottom of the support bracket which is applied to the base of the machine directly beneath the retaining rod.

*Pot Pump Spring*—The pot pump spring pressure can be altered by either shifting the upper end of the spring to the various nicks in the pot pump spring lever or by shifting the pot pump lever spring adjusting hook, located on the inside of the column. On the late model machines, the spring pressure can be altered from the operator's chair by turning the pot pump spring adjusting hook eyebolt nut located in the front of the base.

*Automatic Pump Stop*—The pump stop, when adjusted correctly, will prevent the pot plunger from operating if a short or improperly spaced line is sent in. When the machine is in normal position the short lever of the pump stop should be underneath a hardened block on the pump lever. The adjustment for the pump stop is made with a set screw in the end of the long connecting lever at the end of the right-hand vise jaw. When the line is fully justified, the short lever must be adjusted so it will just clear the hardened block on the pump lever.

The lever 36, shown in the illustration on page 116, which controls the pot pump stop, reaches to the end of the right-hand jaw 38 and has an adjusting screw 37 which rests against the jaw and should be adjusted so that the stop lever 40 will just clear the stop block 42 on the plunger lever when the line is fully justified. Too much clearance will allow a line that is not *quite* full to cast, and the slug will probably show hairlines.

The spring 41 on the stop lever should have sufficient strength to hold the lever under the stop block 42 in case a very short line is sent in, as this creates a slight pressure on the right-hand jaw when the justification levers operate and the spring on the stop lever must be strong enough to overcome it. Sometimes a slight splash of metal gets under the stop lever and causes it to bind; also, as various parts of the machine wear, the stop block 42 might not be lifted high enough to allow the stop lever 40 to come underneath. If such a condition should arise, the holes in the bracket could be elongated to lower it, as there are no dowels in the bracket.



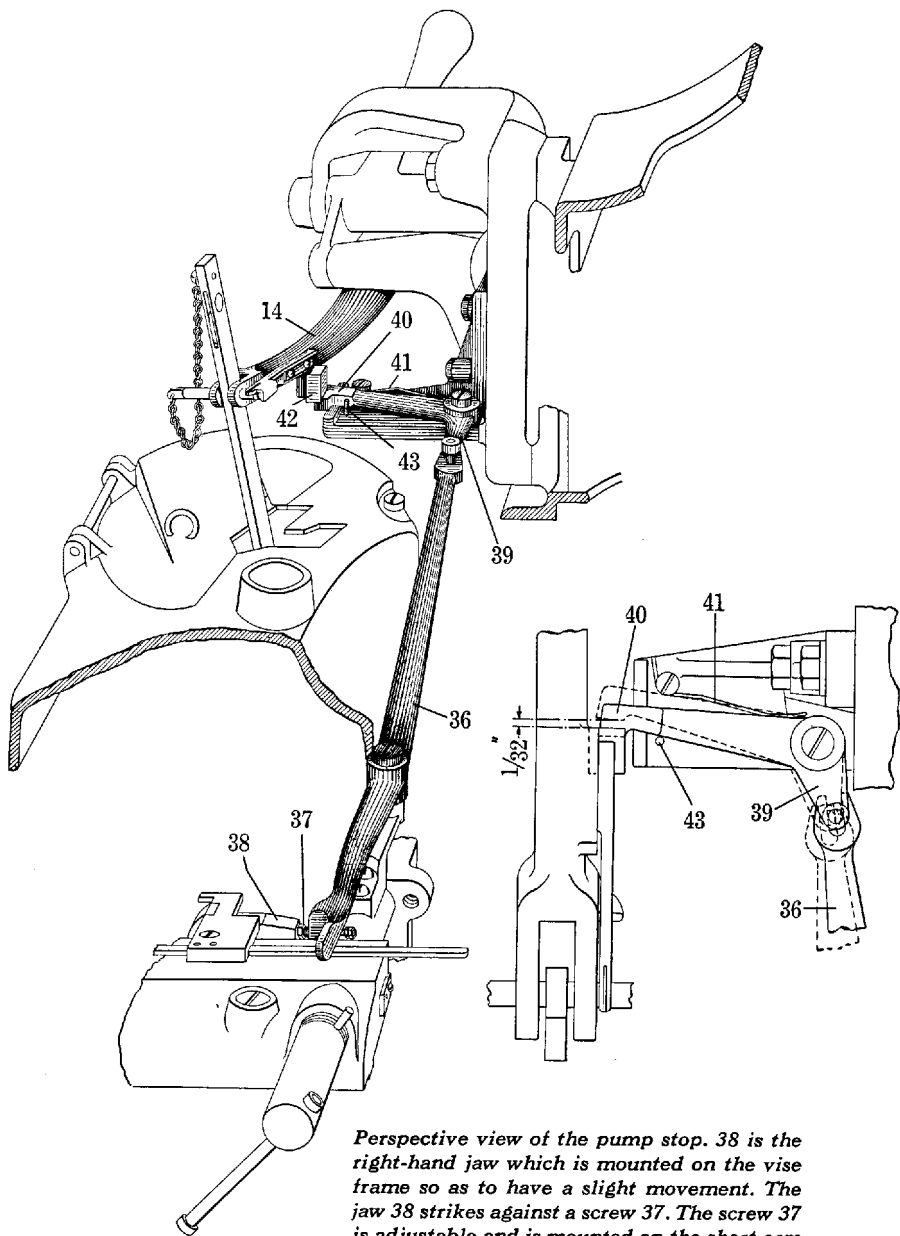

*Perspective view of the pump stop. 38 is the right-hand jaw which is mounted on the vise frame so as to have a slight movement. The jaw 38 strikes against a screw 37. The screw 37 is adjustable and is mounted on the short arm of a lever 36. The long arm of this lever 36 is connected to the short arm of another lever 39; the long arm of the lever 39 has a finished surface 40 on its outer end which operates under a hardened block 42 mounted on the pump lever. The finished surface of the lever 39 is normally under the block 42, being held there by a spring 41 against the stop pin 43.*

*Pot Mouthpiece Wiper*—The pot mouthpiece wiper is bolted to the back of the face plate of the machine and is operated by an extra cam which is built on the side of the first elevator cam. The wiper, which operates with a vertical motion, is faced with a heat-resisting material which wipes the mouthpiece on both its downward and upward stroke. The wiper is brought into operation just after the line is transferred. If desired, the wiper can be made non-operative by pushing in on a slidable pin which is located on the short arm of the operating lever. The face of the wiper must be adjusted so that when it operates it will bear evenly along the entire length of the mouthpiece and will wipe the whole surface of the mouthpiece uniformly.

*Semi Quick-Drop*—The “semi quick-drop” pump cam shoe is standard equipment on most new machines. The shape of this shoe gives more “snap” to the plunger action and helps to produce a better face. On some of the older machines this shoe is rounded at the rear end and hence the plunger action is more sluggish. If the machine is equipped with the rounded shoe, the type face will be greatly improved if it is replaced by the semi quick-drop shoe, which is listed in the Linotype Catalogue as C-1138.

*Quick-Drop Attachment*—The machine is also equipped with what is known as the “quick-drop” which is used *only* when casting display faces. This attachment causes the plunger to make a sudden drop, quickly forcing the metal into the face of the matrices. The pot pump lever latch swings on a screw attached to the plunger lever. To put the quick-drop in operation, turn the latch down to the left, and when the machine makes a revolution the latch will be engaged by the pot pump lever latch cam which is fastened directly under the pot pump shoe. When the contact between the latch and the cam ends abruptly, the plunger is allowed to drop suddenly, forcing the metal from the pot to the face of the matrices instantaneously.

*Linotype Gas and Electric Pots*—Full descriptions of the Linotype Gas and Electric Pots are given in Chapter 13 of the “Linotype Machine Principles” book. Complete wiring diagrams for the Electric Pot, together with a comprehensive analysis of the cause and remedy of various troubles are included.

The following adjustments given in this book should be studied carefully since, if properly made, they will assure correct operation of the Micro-Therm Control.

*Adjustment and Care of the Micro-Therm Electric Crucible and Mouthpiece Controls*—The illustration on page 118 shows the various parts comprising the Micro-Therm electric control for 220 volts A.C. The wiring differs somewhat for other types of current but the expansion unit, switches, indicating lamp, etc. are essentially the same. To adjust, proceed as follows:

Turn switch 259 to *on* position. The switch controls the current for both

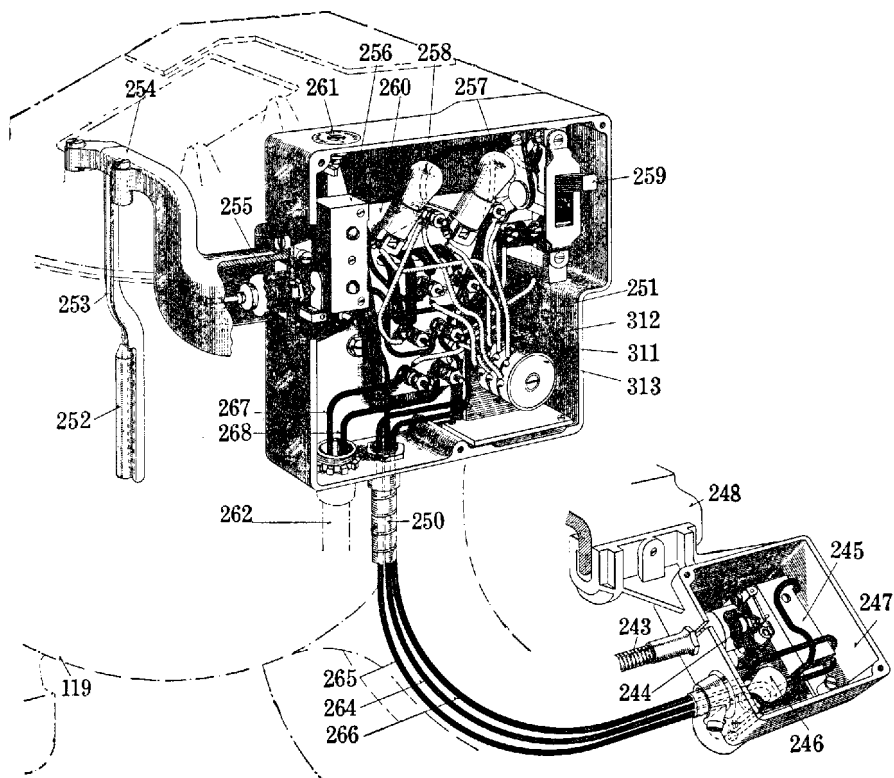

*View showing both the mouthpiece and crucible Micro-Therm control units wired for 220 volt alternating current.*

**Micro-Therm units.** Lamps 257, 258 and 246 will light if metal is cold and lamp 257 will remain lighted as long as current is on. Lamp 258 will remain lighted only as long as current flows to the crucible heaters, and lamp 246 will remain lighted only as long as current flows to the mouthpiece heaters.

After the metal has melted, remove the pot plunger and insert a glass rod thermometer in the pot well. When the thermometer registers 535° F., lamp 258 should go out indicating that the crucible mu-switch contacts have opened. To increase temperature turn pointer on adjusting screw 261 toward "hotter" on dial, or to decrease temperature turn pointer to "colder" on the dial. If it is found necessary to change pointer 261 to obtain the temperature reading of 535°, the factory setting of the expansion tube plunger adjusting nut should be readjusted as follows:

1. Turn adjusting screw dial 261 until pointer registers with the 535° mark.
2. Turn power switch on and allow metal to heat up. When temperature reaches 535°, lamp 258 should go out indicating that the mu-switch 256 has shut off the current to the crucible heaters.

3. If lamp 258 does not go out at  $535^{\circ}$  or goes out before the temperature reaches  $535^{\circ}$ , the setting of plunger adjusting screw should be changed. Loosen lock nut and turn adjusting screw counter-clockwise to decrease temperature and clockwise to increase temperature. Tighten lock nut securely when proper adjustment is reached.

On later Micro-Therm Controls, a different type of adjusting screw dial is used. A raised dial is fastened to the adjusting shaft by two set screws. It is possible, therefore, to adjust the temperature to  $535^{\circ}$  by means of this dial and then loosen the two set screws and turn the dial so that the  $535^{\circ}$  mark agrees with the indicating line on top of crucible control box.

To adjust mouthpiece control, remove cover from mouthpiece control box. The pointer and adjusting screw are fastened to the mouthpiece control box cover and are removed with it. Turn plunger adjusting screw counter-clockwise to decrease temperature or clockwise to increase temperature. Tighten the lock nut, set the mouthpiece pointer to 0 on the dial and then replace the cover and adjusting screw.

On later Micro-Therm mouthpiece controls the setting of the control may be made without removing cover. After removing the lamp "jewel" and loosening the pointer set screw, the adjusting shaft can be turned clockwise to increase temperature and counter-clockwise to decrease temperature. After this setting is made, pointer should be set at 0 on the dial, the pointer set screw tightened and the "jewel" replaced.

To replace a damaged expansion tube and bulb assembly move switch 259 to "off" position, remove guard 254 and four round-head screws from the cover of the expansion bellows 255. The expansion bulb can then be lifted from pot. The plunger adjusting screw assembly should be transferred to the new bulb. Reverse procedure when inserting the new bulb. The mouthpiece control expansion tube and bulb assembly is replaced in a similar manner.

The expansion tube and bulb assembly must not be inserted in the pot until it has been exposed to room temperature ( $70^{\circ}$  F.) for at least one hour. When the expansion bulb is inserted in the pot crucible, it should be  $\frac{1}{2}$  inch away from the heating units. If the bulb is closer than  $\frac{1}{2}$  inch, it may be permanently strained and will operate incorrectly.

Do not permit the crucible or mouthpiece to overheat ( $600^{\circ}$  F. for crucible,  $525^{\circ}$  F. for mouthpiece) since this may damage the expansion tube and bulb of the Micro-Therm Controls.

*Adjustment and Care of the Mechanical Thermostat*—The thermostat has been accurately adjusted at the factory but must always be readjusted when placed in service. These adjustments should be made as follows:

1. Turn the pot switch to the on position and note that contact lever roller

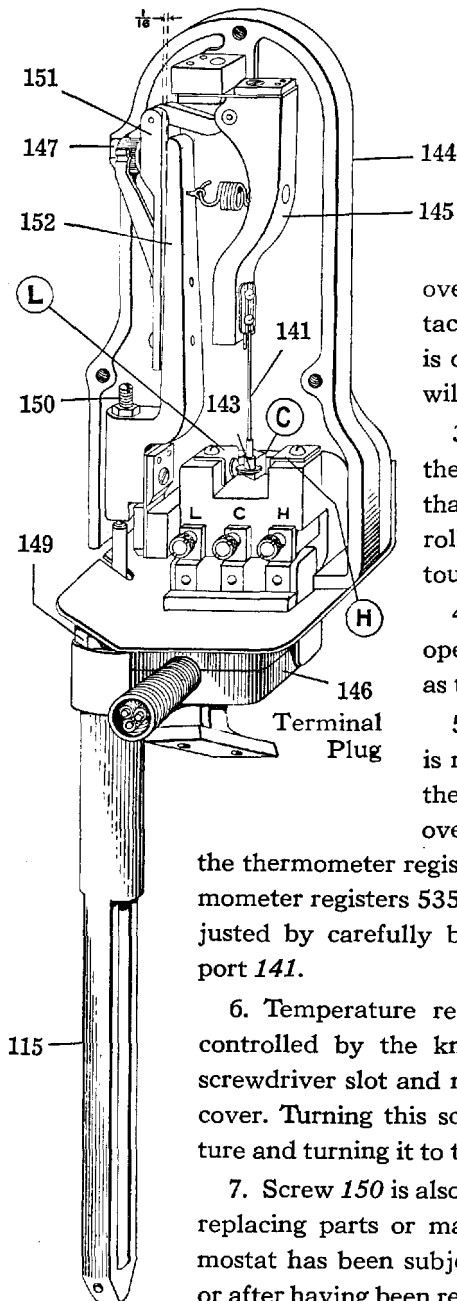

*Mechanical  
Thermostat*

143 is touching contacts C and L. In this position the current is on the crucible heaters and the metal will begin to heat.

2. After the metal has melted, insert a glass rod thermometer and when it registers 550° F., note that contact lever roller 143 has rolled over contact C and is now touching contacts C and H. In this position the current is off the crucible heaters and the metal will begin to cool.

3. When the metal has cooled so that the thermometer registers 535° F., note that the contact lever roller 143 has again rolled over contact C and is now again touching contacts C and L.

4. The foregoing is the normal cycle of operations and will be continued as long as the pot switch is left in the on position.

5. The contact lever roller support 141 is made of spring wire and is set so that the contact lever roller 143 will easily roll over contact C and touch contact H when

the thermometer registers 550° F. and contact L when thermometer registers 535° F. The contact roller 143 can be adjusted by carefully bending the contact lever roller support 141.

6. Temperature regulation above or below normal is controlled by the knurl-headed screw 147 which has a screwdriver slot and may be reached through a hole in the cover. Turning this screw to the left reduces the temperature and turning it to the right increases the temperature.

7. Screw 150 is also an adjustment, but is used only when replacing parts or making rough adjustments if the thermostat has been subjected to extremely high temperature, or after having been removed from a frozen pot.

8. It is important in making this rough adjustment with screw 150 that a clearance of at least  $\frac{1}{16}$ " be allowed between

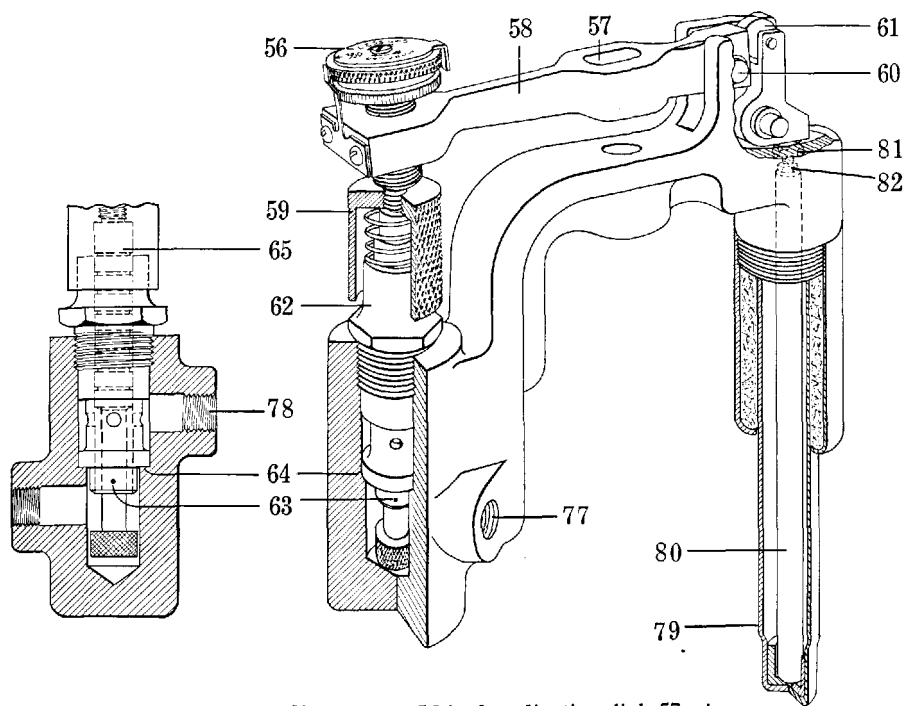

*View of the Gas Pot Thermostat. 56 is the adjusting dial; 57, clearance hole for screwdriver; 58, lever; 59, spring cap; 60, fulcrum pin; 61, roller; 62, plunger guide; 63, by-pass; 64, seat for guide; 65, plunger; 77, gas inlet; 78, outlet; 79, steel casing; 80, invar rod.*

parts 151 and 152 to provide for the close adjustment to be made by screw 147.

9. To remove the thermostat and pot cover from a frozen pot, remove nut 149 and the two screws holding thermostat to the cover. Disconnect terminal plug 146 by first removing the three nuts and lift off thermostat. The pot cover may then be removed in the regular way.

*Adjustment and Care of the Gas Pot Thermostat*—This thermostat, like similar gas controlling devices, should be taken apart and cleaned occasionally. This can be done quickly and easily if the following instructions are observed:

Referring to the illustration on page 121, remove fulcrum pin 60 by loosening set screws, and then take out lever 58. Unscrew and lift out plunger guide 62. Hold the plunger guide in the hand, unscrew the spring cap 59 and remove the plunger 65. These parts are assembled by hand in the factory and the use of tools or vise may disturb the alignment. Clean out by-pass 63, wipe off and rub plunger 65 with a little graphite. When reassembling do not try to screw plunger guide 62 down to the hexagon head, as it seats on bottom, as shown. Lubricate fulcrum pin 60 with graphite. Do not use oil.

The thermostat is calibrated and the adjustment shown at 81 and 82 set at the factory, where the gas pressure may vary from that of other localities; therefore, test the thermostat by using a thermometer in the metal pot. When the thermometer registers 550° F, loosen the screw at the top of the thermostat and turn the dial plate 56 to agree with the thermometer.

*Adjustment and Care of Micro-Therm Gas Control*—To calibrate the Micro-Therm control, place a glass thermometer in pot, loosen dial set screw 93 and shaft set screw 95, shown in the illustration below. Then turn operating shaft 94 to the left or counter-clockwise to raise the temperature and to the right or clockwise to lower the temperature.

When thermometer reaches 550°, adjust shaft 94 by turning to the right or clockwise, until main burner flame is cut down to pilot flame. Line up the 550° graduation mark on dial 89 with one on the casting and then lock dial and shaft in position with lock screws 93 and 95.

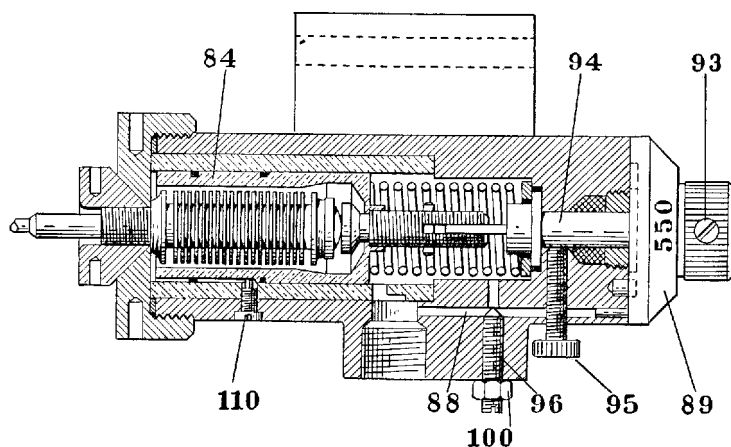

*Detailed sectional view of Micro-Therm Gas Temperature Control.*

The pilot light can be adjusted by first loosening lock nut 100 and then turning the pilot light regulating screw 96 to the right or clockwise to reduce the flame or to the left, or counter-clockwise, to increase the flame. This will regulate the amount of gas flowing through the pilot light by-pass 88. When making this adjustment the main inlet port should be closed by turning operating shaft 94 clockwise as far as it will go. The by-pass flame should be adjusted just high enough to prevent it popping out.

To replace a damaged expansion bellows, first turn the gas flame down. Remove the expansion bellows tube guard, loosen bellows retaining nut before loosening enclosing nut; then remove bellows tube assembly and replace

with new one. Tighten enclosing nut and then tighten bellows retaining nut. To clean, go through the same process with the addition of removing piston by loosening set screw 110. Clean thoroughly and wipe piston with graphite before reassembling. The expansion tube and bulb assembly must not be inserted in the pot until it has been exposed to room temperature (70° F.) for at least one hour.

*Metal Temperature*—The temperature of the metal on a gas pot should never go higher than 550°, and it may give better results a trifle below that. The electric pot usually gives better results when operated at a temperature between 535 and 550°.

### **Ejection of Slugs**

If a slug does not eject properly from the mold see if the ejector is set to correspond to the length of the slug being cast. Also see if the trimming knives are set correctly for the body of the slug. Do not try to force the slug from the mold until these two items have been checked.

To inspect the mold when a slug refuses to eject, push in on starting lever and turn the cam shaft backward by pressing down on the first elevator cam as far as it will go, which will release the pressure against the ejector lever pawl. Then pull back on the ejector lever handle and continue to turn the cam shaft backward until the mold disk is free from the locking studs which will allow the mold disk to turn.

If the trimming knives are set to a smaller size than the body of the slug, turn the machine backward by the same procedure as before mentioned, so that the slug will not press against the knives and they will be free to open.

If a slug hesitates when it is being ejected, this may be caused by mold liners with rough ends, the mold may have an accumulation of metal on its sides, the trimming knives set so as to dig into the sides of the slug, the trimming knives dull or nicked, the driving clutch leathers lifeless, worn or gummy, or the inside rim of the driving pulley may be slippery. A hollow slug, porous enough to allow the ejector blades to penetrate it, will either hesitate at the ejection point or not eject at all.

*To Remove Ejector Slide*—If it becomes necessary to remove the ejector slide from the machine, the vise must be opened to the second position. Turn the machine until the first elevator slide head rests on the vise cap and shut off power before the mold slide advances; then open the vise to the first position and withdraw the pin against which the bottom lug on the vise rests, lowering the vise carefully. Before the mold slide can be drawn all the way out, the ejector blade controller 3 (shown on page 124) must be released by removing the controller link rod 18, which has a slot for a screwdriver at its end and must be loosened from the link lift 20 to allow the blade



controller to drop out. This must be done with the mold slide in normal position. If the machine has a water-cooled mold disk, the hoses must be disconnected. The mold slide can now be withdrawn from the machine after it has been disconnected in the usual manner.

**Replacing Damaged Ejector Blades**—If a damaged ejector blade is to be replaced, remove the ejector slide keeper 17 which is fastened with a screw at each end, and also the ejector slide 4.

The ejector blade guide 7 is held in place with three screws at the top and three at the bottom. The front screws are directly under the rim of the mold disk, but there is sufficient room to take them out without removing the mold disk from the mold slide.

The ejector blade 1 is fastened on the ejector blade link 2, and it is necessary to have them fit snugly when they are connected. The blades must be of equal length, and the front ends must be square and have the full thickness

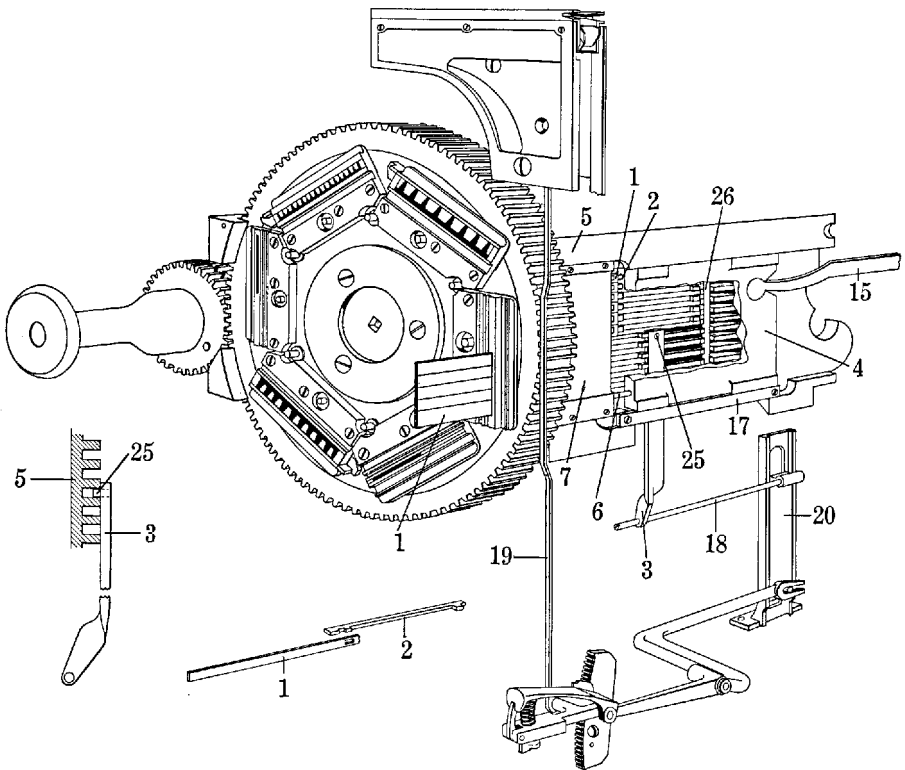

*View in detail of the mechanism of the universal ejector blade with the 24½-em six-mold disk. The mechanism is exactly the same when used with the four-mold or the 30-em six-mold disks.*

(no rounded edges). If the end of the ejector blade is thin it might sink into the back of the slug when ejection is taking place, and cause the slug to stick in the mold.

The ejector blade link stop 26 is made of steel and its outer projections are tapered to guide the blade controller pin 25 into the slots when the ejector blades are moved forward, and if the taper on the projections becomes too badly worn, the link stop should be replaced.

When reassembling the ejector blades, every part, including the slots in the mold slide, should be thoroughly cleaned, so that when the ejector blade guide 7 is fastened in place, the ejector blades will slide freely when the screws are tightened. Also connect the ejector slide 4 and the keeper 17. After the mold slide is replaced in the machine, connect the blade controller. To get the mold slide in position to do this, note first that the lower edge of the mold slide near the rear end has been cut out about  $\frac{1}{2}$ " in length and  $\frac{3}{16}$ " deep, and to get the controller in the correct position to be raised, have it directly opposite the cut in the mold slide, with the pin 25 toward the left side of the machine, and have the ejector slide nearly all the way back which will bring the ejector blade links in a position where they will clear the controller when it is raised. Fasten controller in place with the rod 18.

*Adjusting Stroke of Ejector Lever*—The illustration on page 126 shows the operation of the ejector lever. 12 is the ejector lever adjustable pawl, which is held in position by the adjusting screw 27. When the slug is to be ejected the ejector cam 16 comes in contact with the pawl 12. The travel of the ejector lever is controlled by the adjusting screw 27. If the ejector blade does not come far enough ahead, turn out on the adjusting screw 27 which will allow the ejector lever pawl to come lower and remain in engagement longer when the slug is ejected. If the ejector blade comes too far ahead, lower the adjusting screw to raise the pawl.

On the forward travel the ejector blade should be adjusted to come slightly beyond the front end of the lower liner in the knife block. If the blade comes too far forward, the slug may strike the slug adjuster, and hesitate when dropping into the galley. On the lower part of the ejector lever there is a shoe 13 which returns the lever to normal position. In case the shoe should be lost or become loose, the blades would not be fully withdrawn from the mold and they might be damaged when the disk started to revolve.

*Removing the Ejector Lever Adjustable Pawl*—If it becomes necessary to remove the ejector lever adjustable pawl, there are two ways of doing it.

The first way is to turn the machine backward until the ejector lever 11 can be pushed ahead far enough to bring the head of the pawl screw 29 opposite the opening in the side of the main driving gear (where the roll 9 travels) and

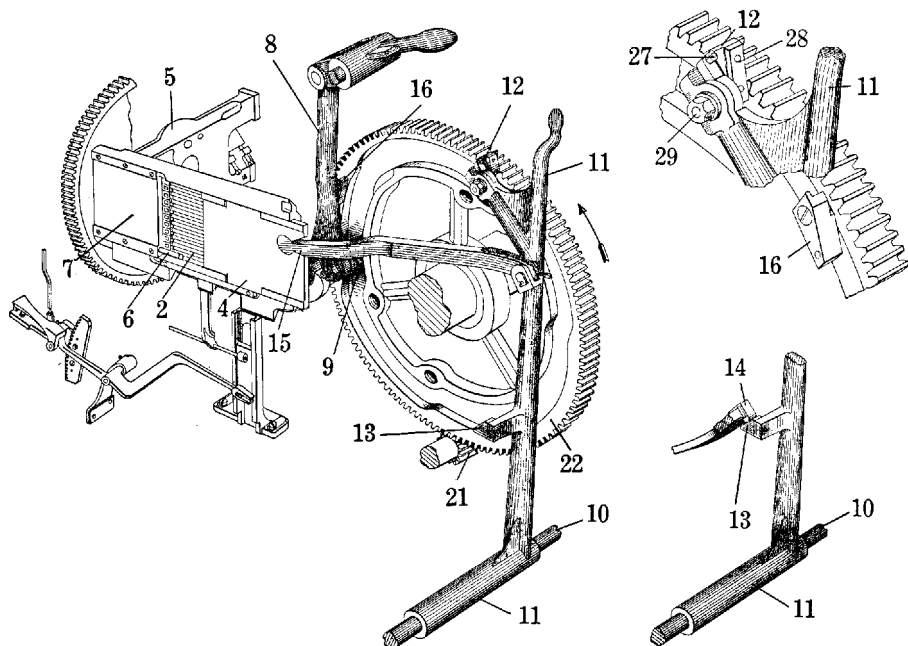

*View showing the ejector lever and the cam which operates it, together with the large gear 22 meshing with the pinion 21 on the jack shaft. This gearing causes the rotation of the cam shaft.*

in this position the screw can be loosened all the way; then disconnect the spring which is fastened to the bottom of the pawl with a screw.

A second and easy method of removing the pawl is to place flatwise a hammer handle that will just fit between the main driving gear and the front end of the ejector lever near the pawl, then twist the handle sidwise, which will move the ejector lever away from the main gear far enough to give sufficient clearance to remove the screw 29 from the pawl.

If the pawl plate 28 shows wear at its lower end, replace it so it will give the proper travel to the ejector lever. The pawl spring should be connected before the pawl is replaced.

*Failure of Slugs to Eject*—Sometimes a slug will fail to eject, and it may be that the slug is hollow, or the trimming knives may be set wrong; for instance, if the knives are set to trim an 8-point slug and a 10-point slug is cast it would be impossible for the ejector to push it through until after the machine is backed up and the knives readjusted. To do this, push the starting lever in and turn the machine backward as far as possible by pressing against the first elevator cam, and when it comes to a stop, pull back on the ejector lever

11 and continue to turn backward until the slug is far enough away to allow the knife to spring into place when the proper setting is made.

Examine the knife wiper bar rod to see that it does not bind, and that the return spring is of sufficient strength to raise the rod to its full height. If the rod is not fully raised, it will leave the wiper in front of the slug being ejected, and cause it to stick.

An ejector blade not set the full length of the slug to be cast will interfere with proper ejection. Another cause of slugs sticking in the mold is rough mold liners. To remedy this, rub the ends of the liners with a fine oilstone, being careful not to change their taper.

*Removing a Stuck Slug*—If a slug sticks in the mold it may be bound at one end only, and to examine it, turn the machine back in the manner just described. When the mold disk clears the stud blocks, turn the disk to the left and loosen the right-hand mold cap screw; then turn the mold disk back to ejecting position and if the slug is not hollow it can be pushed out with the ejector blade. Tighten the mold cap screw before casting another line.

If the slug is hollow and does not eject when the mold cap screw is loosened, turn the machine backward and lift the ejector pawl 12 to clear the cam 16; then allow the machine to turn to normal position, and loosen the three mold cap screws to free the slug.

### ***Knife Block***

As the slugs pass through the knife block the sides are trimmed to make them parallel and the correct size. The left-hand knife must be adjusted to trim any overhanging portion of the type face without trimming the body of the slug. The knives must be kept sharp and free of nicks. In order to trim slugs parallel there can be no lost motion in the slide bearings.

The maintenance of the knife block is principally a matter of adjustment, rather than the replacement of the various parts. (See illustration on page 128.)

The left-hand knife rests against the adjusting screws 5 and is held in place with two square-headed screws passing through the vise frame. It is possible for this knife to be forced away from the adjusting screws if it should be subjected to some undue strain, as there is no support on its left-hand side. If that should occur, it is only necessary to loosen the two square-headed screws in the knife and the spring 4 will bring the knife back to its original position.

*Adjusting the Knives*—If the left-hand knife is to be adjusted to trim the slug closer to the edge, loosen the lock nuts 17, and turn the adjusting screws 5 out slightly before loosening the square-headed screws in the knife.

The right-hand knife is fastened to the movable slide 9 with two hexagon-head screws 8. Before adjusting this knife, examine the slide 9 and determine

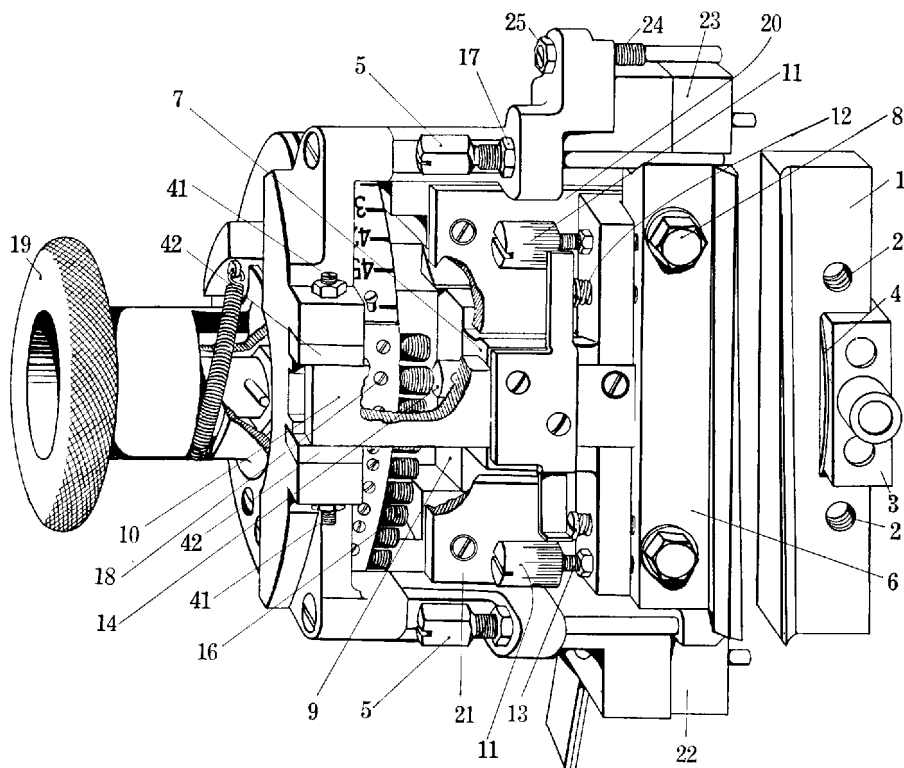

*View showing rear of knife block.*

if there is any lost motion. If so, it will be difficult to keep the knives parallel when different length slugs are set. To make the adjustment, two screws located on top of the knife block casting reach to a gib placed over the top of the slide, and as the screws are turned down, the gib presses on the top of the slide to eliminate excessive play.

A simple way to make this adjustment is to first turn the knife block so that the scale registers 5 point, then loosen the lock nut on one of the adjusting screws, and turn the screw down tight against the gib, which will lock the knife slide at 5 point. Open the knife block all the way until the dial registers 45 point, which will leave a space between the setting screw button and the setting screw. Then with a screwdriver, loosen the adjusting screw very slowly until the slide snaps over against the setting screw. Hold the screw steady and tighten lock nut. Adjust the other screw in the same manner.

After this adjustment has been made, the support gib screws 41 should be adjusted to bring the support gibs 42 just to bear against the slide bracket support 10 to take up the play, but not so tight as to interfere with the adjustment described above.

This additional support adjustment at the right-hand end of the slide 9 is on all late model knife blocks. The adjusting screws are moved just enough to support the end of the slide but must not be tight against it. This adjustment must be made after the first one is completed.

If the slide should become gummy and not slide freely in the guide, a small amount of kerosene applied on the bearing surface will cut the gum and also act as a lubricant.

When adjusting the right-hand knife for parallel, use slugs of the maximum width-capacity of the machine, then loosen the lock nuts on the micrometer adjusting screws 11, and when the adjusting screws are moved, the marks will show how much the knife will change when the knife clamping screws 8 are loosened. When the knife has been set parallel, tighten the lock nuts on the adjusting screws to hold them in place. A micrometer must be used to measure the slugs to determine the exact setting.

Each of the setting screws, as shown at 16, is independently adjustable so that slugs of any point size can be trimmed "close" or "full." This is sometimes desirable for spacing effects between lines.

If the slug measures the same at both ends, check the ribs at the center of the slug and see that they correspond with the measurement at the ends. If the center ribs measure thinner than the ends, the right-hand knife may be warped, and if so, it may be necessary to use an oilstone on the edge of the knife to make the slug parallel. It is very important that the ribs on the slug measure the same all the way across, otherwise when a change is made from wide to narrow measure, the short slug might not be parallel.

When setting the knives use lower case matrices in the "test" line. Capital letter matrices have a slight overhang, and when the slug is trimmed, there is more metal to remove, resulting in more pressure on the knives and a possible slight variation in the setting. This will be particularly noticeable on machines that have been in use for some time.

If slugs are "off their feet," (the bottom thinner than the top of the slug) it may be caused by the left-hand knife not trimming close enough and leaving an overhang at the top of the slug. This condition may also be caused by dull knives, worn or loose mold locking studs, or worn stud blocks.

To insure a slug trimming parallel there must be no lost motion in the mold locking studs or stud blocks. To test this, leave the vise closed and turn the machine backward until the mold disk is fully advanced and the locking studs are in place, then pull ahead on the handle of the mold disk pinion and rock it from side to side to see if there is any lost motion in the mold disk. If there is any looseness, the locking studs or stud blocks are worn.

The knife block is fastened to the vise frame with two hexagon head screws.

Before removing the knife block from the machine, it is important to see that the lock nuts are tight on the left-hand knife adjusting screws.

If the screws are not locked in place they might move, and when the knife block is fastened in place the set screws might force the left-hand knife out of place. Also see that the surfaces of the liners 22 and 23 are perfectly clean, so that when the knife block is fastened in place the knives remain parallel.

*Showing details of the spring plate 27; 28 is the spring plate spring, and 29 and 30 show the lower and upper lugs on the spring plate. 31 shows the two studs with undercut heads.*

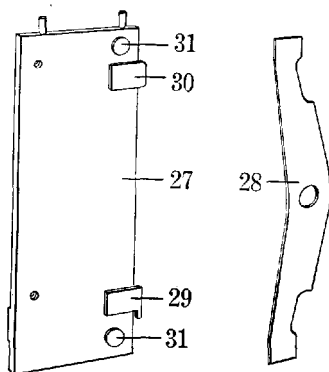

If the knife block is removed from the machine for repairs, test the knives for parallel after it has again been fastened in place on the machine.

Referring to the illustration above, 27 shows the right-hand side spring plate on which are riveted two lugs, 29 and 30. The lower lug 29 has a small projection extending from its lower side; on the inside at the lower end of the right-hand knife there is a slot with a pin across, and the projection on the lower lug fits over the pin in the knife to keep the spring plate in position. 28 shows the spring that forces the spring plate to the left; 31 shows the two studs with undercut heads.

On the later model machines the spring plate is fastened to the slug plate with two screws. The movement of the slug plate is thereby limited in constant relation to the right-hand knife. The purpose of this is to eliminate the possibility of damage to overhanging characters on slugs, and maintain the spring pressure on regular slugs. The movement of this side spring plate is limited by the screws to .005".

When the knife block is being assembled, place the projection of the lower lug 29 over the pin in the side of the right-hand knife. It will be noticed that spring plate spring 28 has the side cut away at each end. The ends of the spring fit under the cutout heads of the studs 31 and below that point the spring is cut away enough to clear the spring plate lugs when the spring plate is pressed down.

The right-hand vise jaw adjusting screw 24, shown in the illustration on page 128, controls the position of the type on the face of the slug so that it will have neither an indention nor overhang.

When an adjustment is made with this screw, see that it does not affect the adjustment of the pot pump safety stop.

*Sharpening the Trimming Knives*—If the side trimming knives are very dull, or the edges nicked, they should be returned to the Linotype Company to be ground. Send both knives, as they are ground in pairs to make sure they will always be of equal height.

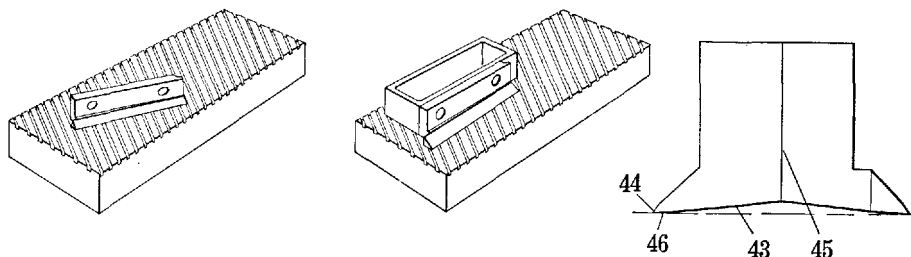

*Showing correct procedure in sharpening the trimming knives. The view to the right illustrates how the knives are tapered for proper trimming and smooth ejection of the slug.*

If only the edges of the knives are dull, they may be dressed with a lapping block and an oilstone. A lapping block suitable for this purpose can be obtained from the Linotype Company, listed in the Linotype Catalogue as F-317, together with a knife support block F-701, and No. 120 powdered emery, X-491, also to be used in lapping the knives.

For best results, proceed in the following manner: Sprinkle the surface of the lapping block with the powdered emery and moisten with kerosene. Hold the face 43 of the knife flat on the lapping block and rub, as shown to the left in the illustration above. The face 45 should then be held firmly against the knife support block and the cutting edge 46 rubbed over the lapping block, as shown in the middle view, being careful that this edge is not ground back farther than  $\frac{1}{64}$ ". Then dress the edge 44 with a fine oilstone.

The taper allows the slug to be ejected with the least possible resistance, and the original angles of the knives must always be preserved to prevent them from digging into the slug when trimming.



---

# DISTRIBUTION

---

## *Transfer*

After the line is cast the first elevator slide rises to its highest position where the matrix line is transferred from the elevator jaws to the second elevator bar. The transfer must be smooth, without noise or friction. If a line of matrices does not transfer properly it may be that the recasting block at the bottom of the vise frame is not thrown far enough out of the way, or there may be metal or dirt on the adjusting screw at the bottom of the elevator slide. The screw that holds the slide stop to the elevator slide may be loose, bent or broken; the matrices may bind in the first elevator jaws, or the matrix retaining pawls may be too strong or of unequal tension. The finger on the transfer slide may be bent and not press squarely against the matrices, the underside of the second elevator bar plate may be burred or gummy, or there may be metal or dirt on top of the intermediate channel where the second elevator bar plate rests. A bent spaceband or a matrix with damaged teeth would also interfere with the transfer. The roll on the second elevator cam lever must clear the cam when the machine is in the transfer position.

With improper adjustments of the transfer mechanism the combinations or teeth on the matrices will be quickly damaged, and will affect the distribution of the matrices as they are carried along the distributor bar.

*Adjusting the Transfer Alignment*—Before making any adjustment see that the front screw at the very bottom of the elevator slide is tight against the slide stop. The screw may be loose, bent or broken; if it is damaged, replace it before attempting to make the adjustment. Also try a matrix in the first elevator jaw and see that the back jaw is straight and holds the matrix correctly without being too loose.

Start the machine and allow it to revolve until the first elevator slide is part way on its upward travel, then open the vise and insert a thin pi matrix between the elevator jaws near the right-hand end, close the vise, lock the spaceband lever so the transfer will not operate; and then have the machine revolve until the elevator slide comes to rest against the top slide guide, which will bring the machine to the transfer position. Then move the matrix in the jaw toward, but not quite against, the second elevator bar, and insert a strip of white paper in an upright position just to the left of the spaceband pawl.

Place a light so it will shine on the left side of the paper, and by looking through the elevator jaws from the left-hand end, the reflection of light on surface of the white paper will clearly show the alignment of matrix teeth with the second elevator bar, and the adjustment must be made so that matrix teeth show a slight clearance at all points.

If the matrix teeth are too high to align with the second elevator bar, loosen the lock nut on the back adjusting screw at the bottom of the slide and turn in on the screw until the elevator slide has been lowered enough to show light equally at the top and bottom of the teeth. Reverse the movement of the adjusting screw if the matrix teeth are too low. After the height of the elevator slide has been correctly set, hold the head of the adjusting screw with a pair of pliers to keep it from moving when the lock nut is tightened.

After the elevator slide has been adjusted to the proper height, see that the matrix teeth show light equally at the front and back.

After the machine has had considerable use the second elevator bar plate may show a slight wear on its front surface; to compensate for this wear there is an adjusting plate on the intermediate channel front plate, resting against two adjustable bushings, through which screws pass to hold the plate in place; after the screws are removed, the bushings may be turned in the direction to bring the second elevator bar in alignment with the matrix teeth. In most cases it will be found necessary to turn the adjusting screws out to move the adjusting plate farther back. All these adjustments must be carefully made and if correct, the light will show evenly between each matrix tooth.

While the machine is still in the transfer position, test the intermediate bar, which pushes down spaceband long wedges and matrices which do not drop of their own accord, to see that it has the correct setting after the transfer adjustment has been made. Move the matrix the entire length of the elevator jaws and see that there is a slight clearance between the matrix teeth and the bottom of the bar and also see that the pawl at the bottom right end of the bar is free and in line with the second elevator bar.

The intermediate bar is held in place with two screws and its top banks against two adjusting screws. If the bar is to be raised, turn out slightly on the adjusting screws, loosen the screws that hold the bar in place and press the bar upward against the adjusting screws while tightening the other screws.

To have the transfer operate smoothly, the matrix retaining pawls in the first elevator jaws must have an equal amount of tension; if one is stronger than the other, the matrices are apt to be forced sideways when they pass the pawls and interfere with the transfer operation.

The pawl on the back jaw of the first elevator is fastened with two small screws, which must be entirely removed to release the pawl. The pawl on the

front jaw has a long slot at one end, and to remove it use a long thin screwdriver and pass it through the hole in the elevator slide, which will bring the screwdriver in line with the screws which bind the pawl. Turn out slightly on the screws and pawl can easily be withdrawn without removing screws. To get even tension on the pawls it may be necessary to bend them with pliers.

Another important point is to have the transfer slide finger perfectly straight. The edges must be straight to press squarely against the matrices when the transfer is being made.

On all late model machines the line stop is automatically carried to the right by the line stop transfer rod. The line stop should move freely so as not to interfere with the transfer action or retard the movement of the line of matrices and spacebands as it enters the elevator jaws. The transfer slide should be exactly  $5\frac{5}{8}$ " from the left-hand side of the intermediate channel at which position it will come beyond the left-hand end of the releasing lever.

*Adjusting the Transfer Lever*—The illustration on page 135 shows how the spaceband lever 42 is connected to the transfer lever 36 with a turnbuckle 43 having eyebolts with right- and left-hand threads to adjust the position of the spaceband lever, but the movement of the turnbuckle has no effect on final adjustment of transfer lever.

When an adjustment is to be made with the turnbuckle it can be done from the front of the machine by using a punch or a short steel rod that will pass through the hole as shown in the enlarged view of the turnbuckle 43, and can be adjusted by reaching in back of the left-hand end of the keyboard.

It will generally be found that if the left-hand side of the transfer slide finger is slightly beyond the intermediate bar the setting will be nearly correct.

When the transfer lever is correctly set the distance between the transfer slide finger and the left-hand end of the intermediate channel front plate should measure  $5\frac{5}{8}$ ".

If adjustment of the transfer lever is necessary, have the machine in normal position. Loosen the two screws in the split cam lever 40. To loosen the front screw it will be necessary to have a very thin open-end wrench, or if that is not available, remove the line delivery air chamber to expose the end of the front screw and use a socket wrench. Lock the spaceband pawl. Then adjust the turnbuckle 43 in the direction to move the pawl to the left until it strikes the latch, then continue to move the turnbuckle in the same direction as before and it will be noticed that the transfer slide will be moved to the left far enough to give the  $5\frac{5}{8}$ " distance. Move the split cam lever 40 until the roll 41 is against the cam and tighten the two screws for a permanent setting.

After the transfer lever adjustment has been completed adjust the turnbuckle back until the spaceband lever pawl will carry the spacebands into

the box, but do not adjust it so that the spaceband pawl will be too far away from the latch, for the reason that when recasting a 30-em line there might be enough movement of the transfer slide to allow the transfer finger 21 to strike the end matrix. The latch usually should just about clear the pawl.

*Adjusting the Transfer Safety Pawl*—When the transfer of a line of matrices is about to take place, the cam shaft revolves until the roller 41 which is connected to the transfer lever comes in contact with the automatic safety pawl buffer 48, the end of which comes against an adjusting screw 49, in the

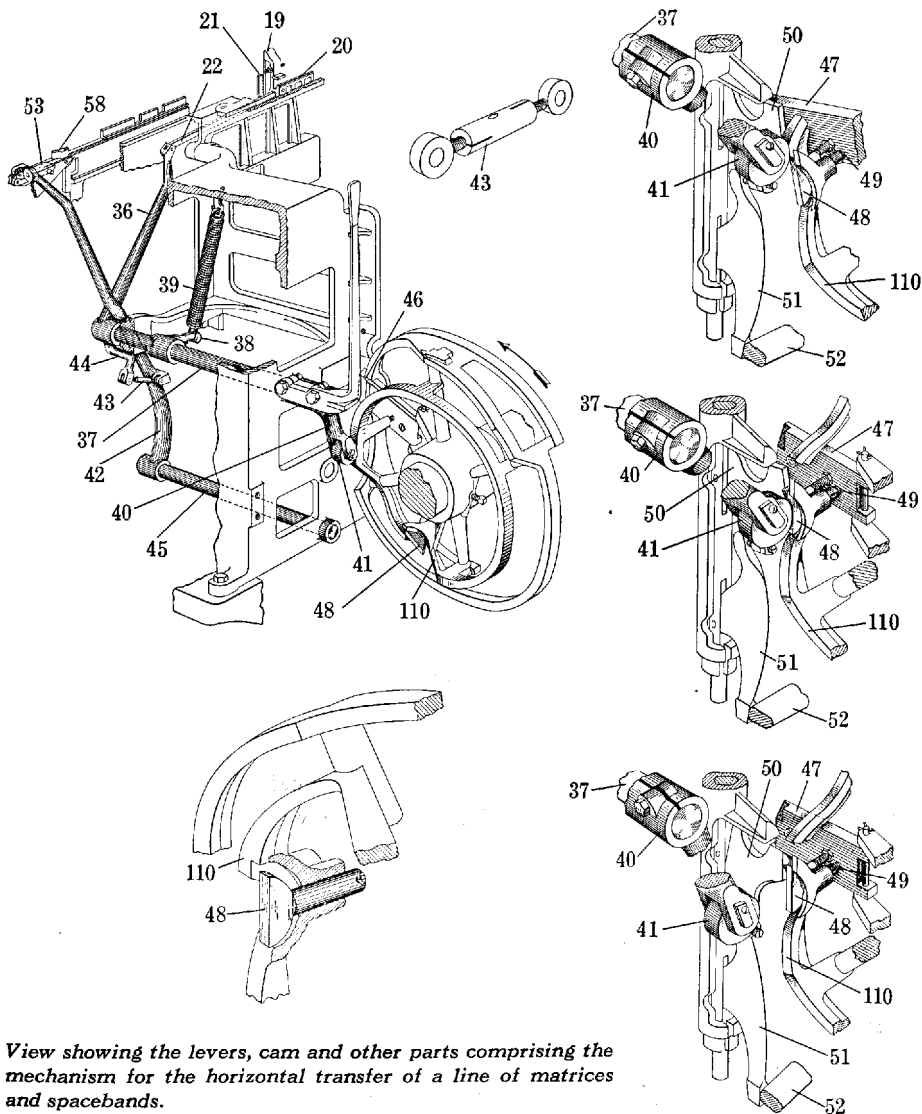

View showing the levers, cam and other parts comprising the mechanism for the horizontal transfer of a line of matrices and spacebands.

safety pawl 47. A test should be made to see that the safety pawl is not carried too far beyond the vertical lever pawl 50.

The automatic safety pawl also carries two stop screws which should be adjusted, to provide stops to limit the motion of the automatic safety pawl in both directions. Their adjustments should be tested; and when they are correct, the stop screw 49 should be adjusted.

When the machine is in the transfer position with a 30-em line of matrices in the first elevator jaws, release the spaceband pawl latch and allow the

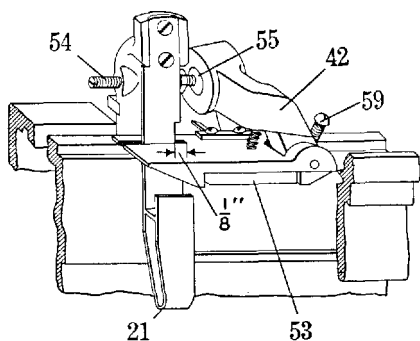

*View showing the spaceband pawl and the slide finger closest together. The spaceband pawl is in position to pull the spacebands to the spaceband box.*

lever to go across very slowly and see that the transfer finger 21 carries the last matrix well onto the second elevator bar before the safety pawl is tripped to start the machine.

If the automatic should trip too soon, and a line of matrices should be slow in transferring, the automatic might trip off before the last matrix was carried into place on the second elevator bar. This would strain the bar as it started to rise, as some of the matrices would still be in the first elevator jaws.

To correct this, move the adjusting screw 49, in the safety pawl 47, farther away from the end of the buffer 48, which will allow the matrices to go farther on the second elevator bar before the automatic trips off.

*Adjusting the Spaceband Lever Pawl*—The spaceband lever pawl 53 fulcrums on a pin as shown in the illustration just above. The pin passes through a split bushing which is compressed and held in place with the screw 59, and is adjustable from front to rear. The narrow straight surface on the bottom of the pawl should be in line with center bar of the spaceband box.

If the spaceband lever pawl 53 fails to carry the spacebands from the intermediate channel, especially if a large number of bands have been used in the line, the spring between pawl 53 and lever 42, may be broken or too weak.

*Adjustment and Care of the Second Elevator Bar*—If the matrices should be carried too far in the transfer and drop off the right-hand end of the second



elevator bar, examine the delivery pawl 107 (see illustration on page 137), the upper end of which extends into the right end of the second elevator bar plate 28, and see if the return spring 112 is broken or too weak to hold the pawl in its downward position.

The pawl 107 is fastened to the second elevator bar 29 with a stud 108, which fits in a hole at the right-hand end of the elevator bar and is held in place by a pin 109, which passes through the bar 29 and the end of the stud. If necessary to replace the pawl, drive out the pin 109, after which the stud can be withdrawn. When the new pawl is in place, see that it works freely after the pin 109 is driven tight.

The second elevator bar is fastened to the bar plate with two screws. If for any reason it is necessary to take the bar off, remove the screws and force the bar from the bar plate and remove the hinge pin 111, which connects the bar to the second elevator link 26, by sliding it to the right; in reassembling, the link must be passed through the bar plate before the hinge pin is put back, and when the bar is fastened to the bar plate the upper end of the pawl must be between the spring and the end of the pawl plunger 113.

When the second elevator has risen to its full height and is in position to transfer matrices to the distributor box, see that alignment is perfect between the second elevator bar and distributor box bar. Any roughness or unevenness on either bar at this point tends to destroy matrix combinations.

There are two guides for the second elevator to position it sidewise. The front side of the elevator bar plate near the center has a portion cut away for a distance of about  $\frac{1}{8}$ " and as it descends the notched portion fits over the second elevator guide, which brings it to the correct position. There is also a slot cut in the end of the second elevator lever 25, and this slot fits over a guide which is fastened to the back of the distributor shifter guide when the second elevator reaches the upper transfer position.

The two guides should receive a small amount of oil occasionally, applied with the finger tip, but the top of the second elevator bar plate and the seat where it rests when the machine is in normal position should be kept perfectly dry and clean. A small amount of graphite may be used occasionally.

The smoothness of the second elevator lever operation depends largely on the proper tension of the second elevator starting spring 78. When correct, it helps the second elevator to start downward and it also cushions the second elevator lever on its upward travel. The spring can easily be changed when the machine is in the transfer position.

*Care of the Distributor Shifter and Slide*—It is very important that the bearing of the distributor shifter slide and the groove in which it travels be kept clean and free from gum and oil. If any lubricant is needed use graphite.

At the right-hand end of the distributor slide guide there is a block which has an adjusting screw to form a stop for the distributor shifter slide. It should be adjusted to come just far enough to allow the matrix buffer to carry a thin matrix to the distributor box lift.

The older machines have a  $\frac{1}{4}$ " round stop screw in place of the adjustable block, and if the screw becomes bent or broken it should be replaced to prevent the distributor shifter slide from striking the distributor box font distinguisher block when lines are being recast when there are no matrices on the second elevator bar.

The tension of the spring on the matrix buffer must be strong enough to carry the matrices against the distributor box matrix lift after the distributor shifter slide has reached the stop screw on the block.

The face of the shifter must be square and straight to carry the matrices evenly against the distributor box matrix lift.

### ***Distributor***

When the second elevator rises to deliver the line of matrices into the distributor box, see that the second elevator bar aligns with the distributor box bar. This alignment can be tested by placing a thick pi matrix on the second elevator bar and allowing the distributor shifter to go across very slowly (by hand) to see if there is any bind on the matrix as it passes the join between the two bars. After the machine has had considerable use the second elevator bar may go too far back. If this condition exists the shifter slide guide, against which the second elevator rests, may be brought forward slightly by placing paper shims behind the casting.

The distributor box adjustments must be maintained correctly to prevent damage to matrices.

The matrix lift must be adjusted to raise the ears of the matrices high enough to clear the top of the distributor box rails before the matrix lugs are engaged by the distributor screws.

Examine the matrix lift, the bar point and the distributor box rails. The lip on the matrix lift must have a square shoulder so the matrices will not slip off when they are raised, and the lift must not engage more than one thin matrix at a time. The bar point must be straight with the bottom of the bar, and the corner must not be rounded nor the point bent sidewise. The distance between the end of the bar point and the edge of the distributor box rails must be a trifle more than enough to allow a .028" thin matrix to clear. If this distance is maintained, only one matrix at a time will be lifted. If a new bar point allows too much distance it may be necessary to replace the distributor box rails if they are worn.



The distributor shifter and the slide in which it travels must be kept clean. If any lubricant is needed use graphite instead of oil.

The matrix lift (on single distributor machines) should remain stationary when there are no matrices passing through the distributor box. This adjustment is made with a small projecting piece called the matrix lift stop which fits in a notch in the side of the matrix lift. The matrix lift stop must be adjusted closely so that when a line of matrices is passing through, the matrix lift will be pushed clear of the projection and allowed to operate.

Use oil sparingly in the distributor screw bearings. An excessive amount of oil here is apt to get on the distributor screws and foul the matrices.

The lower distributor screw must be free in its bearing so that the spring holds the spiral automatic pins in contact. The spring that holds the pins in contact must not be so strong as to cause the ears of the matrices to be bent if there should be a clog in the channel entrance.

*To Remove Distributor Box*—If matrices get caught or bent in the distributor box, remove it from the machine. To do this, turn the main cam shaft backward until the second elevator bar clears the distributor box; pull the distributor shifter back and lock it. Then turn to the right on the distributor box bolt handle as far as it will go. Press the bottom of the distributor box toward the back of the machine until it is released from the locating pins.

Examine the bar point 15 (see illustration on page 142) and see that the bottom is square, as shown at 29. If the corner is rounded, as shown by the dotted lines, there is a possibility that when a matrix is being lifted in the distributor box, the rounded corner on the bar point might allow the following matrix to be lifted against the distributor screw when the first one is lifted and cause it to bind. Also see that the bar point is long enough to prevent two thin matrices from being lifted at the same time. If the two matrices were alike they would drop into the magazine at the same time and the following matrices would clog the distributor.

If the distributor box rails 20 and 22 are worn too much, two thin matrices might be lifted at once even if the bar point is of the right length.

To disconnect the distributor box bar from the box, drive out the hinge pin 44 and the stop pin 45.

Before the distributor box is fastened to the machine for a test, refer to the illustration on page 142, in which a narrow extension on both the front and back plates of the distributor box is shown at 37. It is very important that these extensions be straight, as they form a guide for the matrices so that the slot will be in line with the bar point when they are being lifted.

The lower extensions 38 on the side plates should also be kept straight as they form a guide for the bottom of the matrix to keep the font notch in line

with the font distinguisher. When fastening the distributor box to the machine, be sure the locating pins 39 are in place. Then bring the box back to its correct position before tightening the distributor box bolt. If care is not used when the distributor box is removed or replaced on the machine, the extensions above mentioned are apt to get bent. Never attempt to remove the distributor box when there are matrices on the box rails and the distributor bar at the same time.

**Distributor Box Bar Point**—The point is fastened to the distributor box bar with two rivets which must be driven out if replacement is necessary. When the new bar point is fastened in place see that the bottom is flush and straight with the bottom of the bar; also see that the point is not bent sidewise. When matrices are being raised by the matrix lift, the bar point must be exactly in line with the slot in the matrix, so there will be no interference when the matrix is lifted on the distributor box rails. Bar points are of two different lengths; long and short, depending on the type of machine and the size of matrices used. On some older machines a medium bar point was used.

After the new bar point has been put on, test the distributor box before fastening it to the machine. Use two thin spaces that are marked .028, putting them on the distributor box bar and pushing them against the box rails with a screwdriver. When the first matrix is lifted, see that there is a slight clearance between the bar point and the face of the thin space; if the distance is too great, two thin matrices might occasionally be lifted at the same time. This would be especially noticeable when using thin "quotes."

**Distributor Box Rails**—If the distance is too great between the bar point and the matrix, it may be necessary to change the distributor box rails 20 and 22. These rails are of different shapes for the various models, and when ordering them it is necessary to give the *serial number and model of the machine* on which they are to be used.

The rails are fastened to the side plates of the distributor box with three screws in each one, and they are also doweled. After the rails are in place they should be tested with a small square, as shown at 58 in the illustration on page 142, to see that the ends are the same height.

After new rails are in place, again use a thin matrix to test the proper clearance between the matrix and the bar point. If too close, use an oilstone to shorten the bar point, and when that is correct, examine the lower rails 21 and 23 for wear, and if worn replace them, as the matrix must fit squarely at each corner to be lifted properly.

**The Matrix Lift**—Examine the matrix lift 11 and see that the small shelf at the top is correct. If it is rounded, or not square, a matrix might slip off while being lifted, and bind against the distributor screws. Examine the ma-

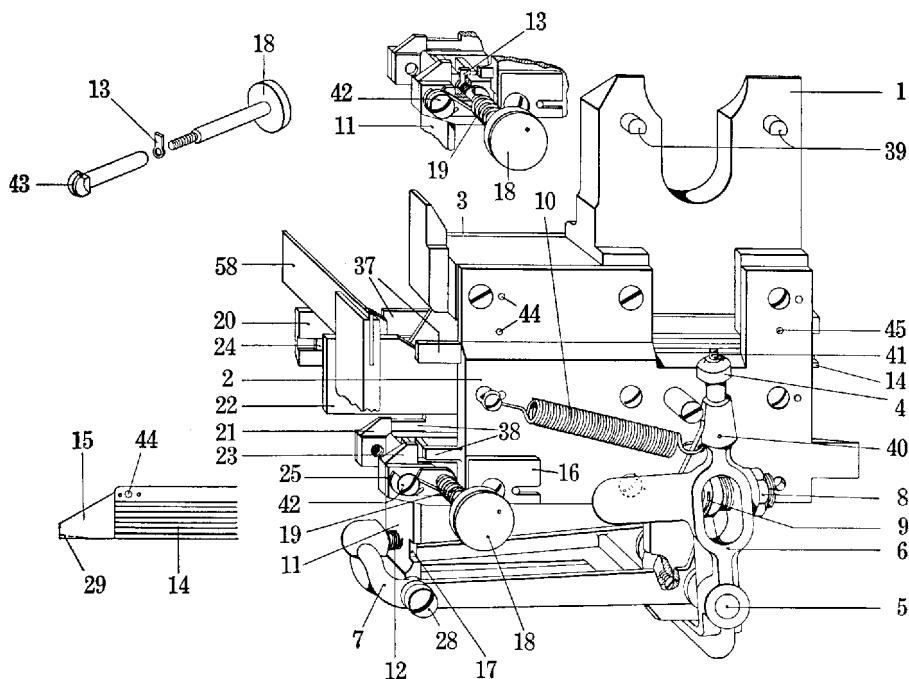

*Back view of distributor box used on the single distributor Linotype.*

trix lift screw 28 for wear. If the stud 41, on which the matrix lift cam 4 revolves should become worn, it can be withdrawn for replacement after the pin 40 is driven out.

**Testing Distributor Box**—Have the machine in normal position, remove the distributor belt, and place a matrix on the second elevator bar and allow the distributor shifter to push it against the rails of the distributor box. Turn the distributor very slowly by hand, and when the matrix has been lifted, see that it travels freely over the rails onto the distributor bar. The rails are doweled, but if the matrix should bind on either one, their position can be changed by tapping them lightly with a hammer, either up or down.

To test the alignment of the rails in relation to the distributor bar, run the matrix just beyond the end of the rails so it is held by the distributor bar, then turn the distributor screws backward. This will show how the rails line up on the sides, and also if they are correct as to height. The matrix should have very little side play between the rails.

**Adjusting Distributor Lift**—The approximate adjustment may be arrived at as follows: Before sending in a line of matrices, first loosen the lock nut on the adjusting screw 8 (refer to illustration just above) and turn out on the ad-

justing screw, which will raise the lift above the proper height so that it cannot get under a matrix to lift it; then send in a line of matrices and allow them to go into the distributor box with the distributor running. With a screwdriver turn in on the adjusting screw 8 until the shelf on the matrix lift 11 comes under the matrix to lift it, then give a slight additional turn before tightening the lock nut. Again remove the distributor driving belt, place a matrix in the distributor box and turn by hand. When the matrix has been raised to its full height, see that the top does not bind against the distributor bar. Usually, the correct setting of the adjusting screw is to have  $\frac{1}{32}$ " , or slightly less—never more—up and down play between the bottom of a matrix held down on the box rails and the shelf of the matrix lift, with the lift in its lowest position.

*To Replace the Font Distinguisher*—If it becomes broken or bent, unscrew the short stud rod 43 from the end of the stud 18; also remove the screw 42 which holds the spring 19. Pull out on the stud 18 until the distinguisher comes in contact with the distributor box lower rail and give it one quarter of a turn to the right which will bring the distinguisher 13 opposite the opening in the lower rail, where the stud can be withdrawn.

When the new font distinguisher is connected to the stud 18, pass it through the slot in the block 25; screw the distinguisher in place with the short stud rod 43 and see that it slides freely in the slot, then connect the spring 19.

If a matrix should catch in the lift and cause the distributor to stop, turn backward very slightly on the knurled knob on the distributor clutch until the matrix is freed. Be very careful not to turn the knob too far backward on the screws as that might possibly cause two matrices to be lifted onto the distributor bar at the same time, and the narrow groove on the screws would not allow them to be carried across. If two matrices should be caught in the way just mentioned, they can be separated if caution is used. Remove the distributor driving belt, then push the matrices in the distributor box away from the rails; turn the distributor screws backward very slowly until the matrix strikes against the lift 11; then press down on the distributor lift lever 7 (the cushion spring 9 will allow this to be done) until it clears the bottom of the matrix. Move the top of the lift to the left and continue to turn the distributor screws backward until the matrix can be pushed down into the box rails, and out of the way of the matrix lift. Then connect the driving belt and allow the matrices to distribute.

*To Open Back Distributor Screw*—Press up on the catch spring immediately over the left side of the distributor box as you face it from the back of the machine, and swing the back screw up until it is caught by the spring pin, which will hold it in an upright position. Do not open the back screw while there are matrices on the distributor bar. The back distributor screw gear has

a locating pin between two of its teeth. When the screw is closed, the locating pin must mesh with the cut-out portion of the front gear.

*Vertical Adjustment of Distributor Beam*—When the matrices are being carried across on the distributor bar, the bottom of the matrices should clear the top of the channel entrance partitions by about .043". If this distance is incorrect, the distributor beam can be set for the proper clearance by means of adjusting screws.

*Horizontal Adjustment of the Distributor Beam*—It is very important that this adjustment of the distributor beam be correct, so that the matrices will not strike the channel entrance partitions when they drop from the distributor bar. This horizontal adjustment is made with an adjusting screw on right-hand end of the distributor beam as it is viewed from front of machine. Before making any adjustment see that none of the channel entrance partitions are bent to the left and that the adjusting screw banks against the distributor beam bracket.

To get the proper adjustment of the distributor beam use a lower case "t" matrix and turn the distributor screws slowly by hand. When the matrix drops from the bar note its position in relation to the channel entrance partition. When the distributor screws are turned slowly the bottom of the matrix should almost touch the partition on the right (viewed from back of machine), as the momentum will carry it slightly farther when the distributor is running at normal speed. Try a matrix in the same way on the "cap" side. If the setting shows to be incorrect, distributor beam should be adjusted.

If the matrix drops too late loosen the adjusting screw a fraction of a turn, then loosen the screws that hold the beam to the distributor bracket in the distributor beam, and with a piece of metal drive it over until the adjusting screw rests against the frame; then tighten the screws and test as before. If the matrix drops too soon, reverse the operation.

When making this adjustment, be careful not to overdo the movement of the distributor beam, as a few thousandths of an inch will make a great difference in the operation of the distributor.

The matrix guard must be free in its bearings, as it is moved backward every time a magazine is raised or lowered, and must be returned to position by its spring when the magazine is seated. If it fails to return, the matrices cannot go on to the distributor bar.

*Spiral Automatics*—The illustration on page 145 shows the spiral automatics 31 and 32. Each of these is fastened to the distributor screws with taper pins 53. The lower spiral 32 has a spring hook 54, and a similar hook 55, is on the loose spur gear 33. If it should become necessary to replace these hooks, the spirals must be removed from the distributor screws.

Before the spiral automatics are removed, mark the spirals, as shown in the illustration, and the ends of the upper and lower distributor screws. Use a straight-edge and make a heavy mark, as shown at 57. This marking must be made slightly off-center, so that when the parts are assembled, and these marks are made to align with each other, the original timing of the distributor will not have been changed.

If the spring hooks on both the spiral automatic and loose distributor spur gear are to be replaced, it will be necessary to remove both the upper and

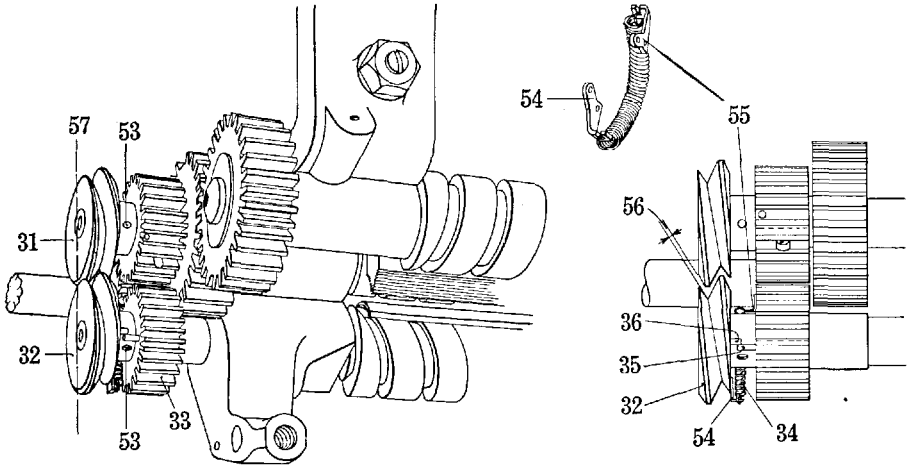

The "spiral automatic" at the ends of the two front distributor screws.

lower spirals by driving out the hub pins 53, which will allow the loose spur gear 33 to be taken off. The spring hooks 54 and 55 are fastened to the spiral and gear with two rivets. On some models the hooks are the same, but on other models they are curved in opposite directions.

When reassembling the spirals, bring the marks at the ends of the distributor screws in line with the marks on the spirals and be sure that the pins 35 and 36 are in position to be held together by the spring 34.

Do not have too much tension on the spring 34. It should be just strong enough to keep the pins 35 and 36 from separating, so that if a thin matrix binds against the lower distributor screw, the matrix ears will not be bent.

If the lower distributor screw does not run freely, do not tighten the spring to force it to turn, but ease the bearing surfaces.

If the lower distributor screw is gummy and will not run forward, a simple way to ease it is as follows: Put the distributor driving belt on the pulleys without crossing, which will run the distributor screws backward. Pour a few

drops of kerosene in the bearings to cut the gum, allow the screws to run for a few minutes and then wipe off the excess kerosene and follow up with oil. This will generally correct the trouble.

**CAUTION**—Oil should be used very sparingly in the distributor screw bearings. If an excessive amount of oil is used, it will get on the distributor screws, and from there it will be transferred to the lugs of the matrices. A few minutes spent in keeping the distributor screws clean will save hours of time that would otherwise have to be spent in cleaning matrices and magazines.

### *Distributor Clutch*

The lower right-hand view in the illustration on page 147, shows the clutch stops 7 and 8 in mesh when the distributor is running normally. When matrices bind against the lower distributor screw, the spirals lock and the clutch stops are separated as shown in the lower left-hand view. In this position, the distributor clutch friction washer 2 will clear the driving pulley and allow it to turn freely.

*Starting the Distributor*—To start the distributor after it has been cleared of matrices, close the channel entrance, grasp the knurled starting lever flange 13, and turn backward slightly. This will unlock the spirals and allow the bottom distributor screw to spring back to normal position with the pins resting against each other. Then pull outward on the knurled starting lever flange 13 and the extension spring 16 will bring the clutch stop blocks 7 and 8 into mesh and allow the clutch collar to bear against the side of the driving pulley to drive the distributor.

*Removing the Distributor Clutch*—If the distributor clutch is to be taken off for cleaning or repairs, begin by removing the knurled starting lever flange 13, which is fastened to the clutch flange with two screws 14; then remove the clutch lever hinge pin, which will release the clutch lever, and remove the hexagon-head screw 28 holding the shaft bracket 15. This bracket has two dowel pins at the top and when it is pressed out to release the dowels, be careful not to bend the main driving shaft. Take out the screw in the spring washer 6, to remove the spring 3; then take out the screw 33 in the shaft, and slide the complete flange assembly off the shaft.

After the clutch has been removed as a unit from the machine it can be more easily taken apart for any necessary repairs or cleaning.

Before re-assembling, the leather friction washer 2, on the clutch washer flange 9 should be scraped clean, and the face of the driving pulley against which the leather rests should be washed with gasoline. Also see that the screws in the clutch stop blocks 7 and 8 are tight.

*Spring Tension*—The tension of the extension springs 16 may be adjusted by loosening the clamp screw in the adjustable collar 17 and moving the collar in either direction to get the proper tension, which should be just enough to spring the stop blocks in mesh when the knurled starting lever

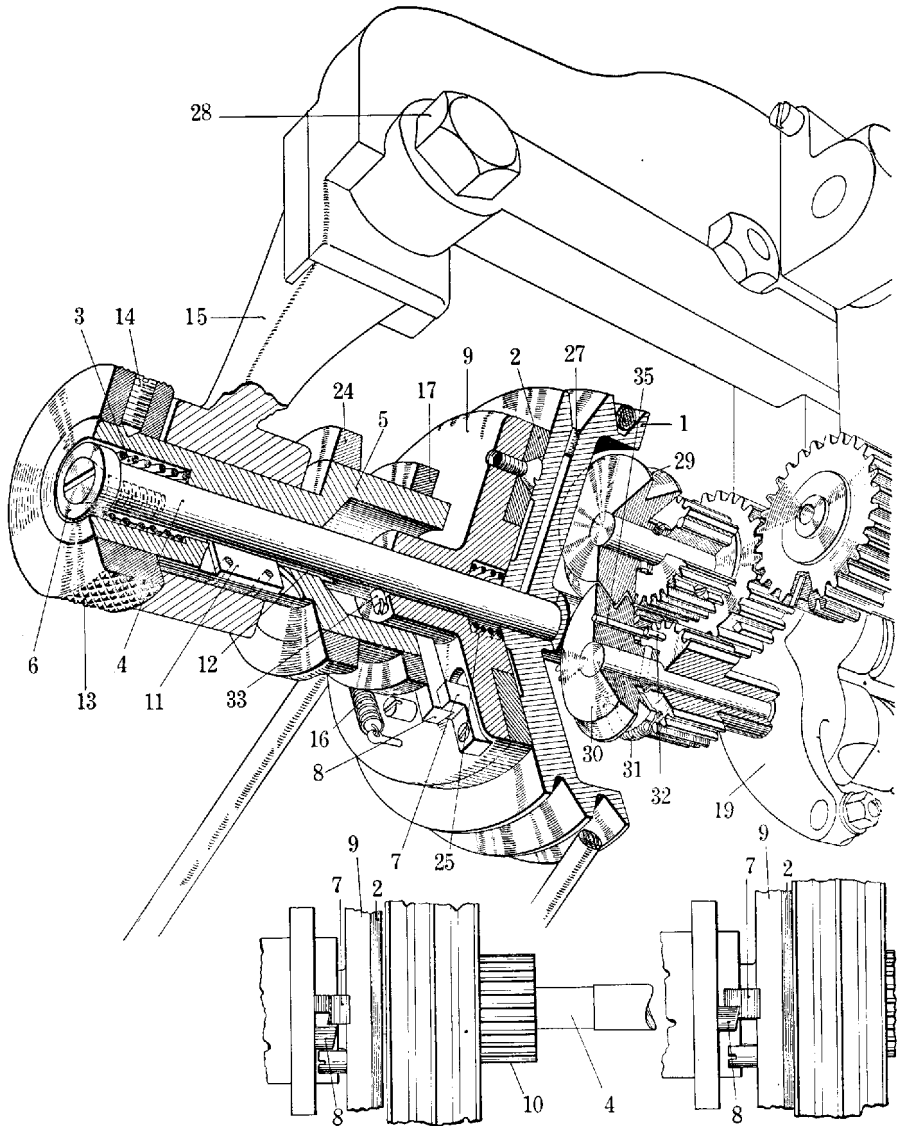

*Perspective sectional view showing details of the distributor clutch. The lower left-hand view shows the stop blocks out of mesh, their position when the distributor is stopped. The lower right-hand view shows the stop blocks in mesh to drive the distributor.*



flange is pulled outward to start the distributor. If the tension is too strong, it might cause the ears of the matrices to be bent should they become caught in the channel entrance and press against the lower distributor screw.

The tension of the spring 3 should be just strong enough to pull the distributor evenly so that when the channel entrance is opened the pointed screw will force the cam-shaped flange 24 to the left to separate the flange assembly from the driving pulley without causing the clutch stop blocks to go out of mesh, so that the distributor will start when the entrance is closed.

*Lubrication*—When reassembling the clutch mechanism, use a little oil on all bearing surfaces, and on the contact faces of the stop blocks 7 and 8. The illustration shows a screw 27 which covers an oil hole leading to the driving pulley bearing. This bearing should be oiled occasionally.

### **Channel Entrance**

The channel entrance guides the matrices from the time they leave the distributor bar until they enter the magazine.

If large size matrices are to be used it will be necessary to adjust the distributor bar beam very closely to prevent the matrices, when released, from striking the channel entrance partitions. To test, run in a lower case matrix of the font to be used and turn the distributor screws by hand very slowly. When the matrix drops from the distributor bar, the bottom of the matrix should barely strike the partition on the right (viewed from the back of the machine). When the machine is operated under power it will be found that the added momentum of the distributor screws will carry the matrices far enough to drop into their channels without interference.

If a very strong spring is used on the spiral automatic of the lower distributor screw, there is a possibility that if the matrices clog in the channel entrance the partitions may be forced out of position. When clearing the channel entrance of clogged matrices, the entrance should be opened with a quick motion to prevent matrices from falling flatwise into the magazine. Sometimes when closing the channel entrance, the lower lug of a matrix may catch between the magazine and the channel entrance and leave a burr in the magazine channel or on the lower partition plate of the entrance. If this happens, remove the burr with a fine file so that the matrices will travel freely.

If the lugs of the matrices become worn too much they may not be guided correctly and the matrix may fall sideways, binding against the guides at the lower end of the channel entrance partitions. The partitions must be in line with magazine channels to correctly guide the matrices. At each end of the channel entrance frame is an adjusting screw which enables the entrance to move forward or backward as required.

When the matrices and magazine are cleaned, the channel entrance between the partitions should also be polished.

### *Two-in-One Distributor*

*Adjusting the Safety Mechanism*—The illustration on page 150 shows in detail the safety device which operates in conjunction with the matrix guard, so that if there are any matrices on the distributor bar, the channel entrances or distributor bars cannot be rotated until all matrices have been distributed, and it is very important that all adjustments are made properly to prevent damage to matrices or distributor bars.

Shown at 107 is the matrix guard lever, the upper end of which rests against the matrix guard, and at the lower end the hardened steel shoe 108 comes in contact with the upper surface of the adjustable steel cam 114.

When making the adjustment, run a matrix on the distributor bar and be sure that the guard lever 107 is set in position, as shown in the diagram. See that the center projection rests against the banking screw 109, and with the upper end bearing against the matrix guard 110. There must be a clearance of approximately .020" between the inside of the matrix guard 110 and the matrix on the distributor bar, as shown at 111. There must also be a clearance of .005" between the end of the lever 107 and the operating stud 112 located on the upper end of the connecting bar 149. These settings can be obtained by bending the lever 107, as it is made of gun metal for this purpose.

Remove the matrix from the distributor and with the lever 107 in normal operating position adjust the screw 113 until the cam 114 just clears the hardened steel shoe 108 on the lower end of lever 107. Now, with no matrix on the distributor bar, adjust the tension on the spring 115 with the screw 138 just so that the front end of the cam 114 will not be depressed when the safety device is operated, but so that it will be depressed if there is a matrix on the distributor bar. Again with no matrix on the distributor bar, adjust the plunger 116 by loosening the lock nut 118 and turning the knurled knob 117 until the upper end of the plunger just clears the point 127 on the steel shoe 108 as it rides over the cam 114 and then lock in this position.

Run a matrix onto the distributor bar by hand and then operate the safety. If all the adjustments are correctly made, the cam 114 will be depressed by the lever 107, permitting the hook 127 on the shoe 108 to hook into the neck on the upper end of the plunger 116, thus preventing the possibility of revolving the channel entrance unit and the distributor bars.

*To Open the Channel Entrance*—The illustration on page 151 shows an end view of the channel entrance and the matrix tray. The matrix tray is held

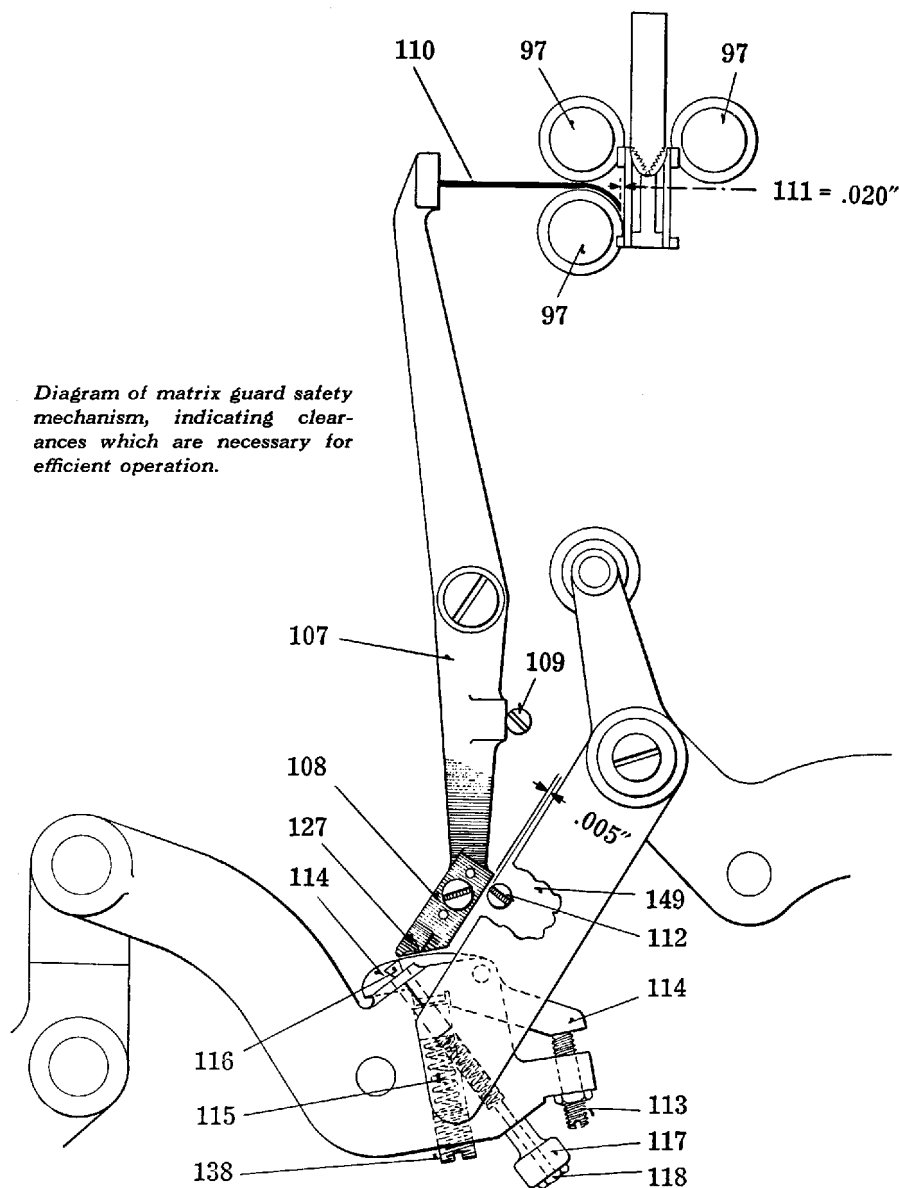

*Diagram of matrix guard safety mechanism, indicating clearances which are necessary for efficient operation.*

up in position by a spring, and whenever the channel entrance is to be opened, press down on the matrix tray 139 before starting to open the entrance so that the guide pin 119 will enter under the shelf of the cam 120 to prevent the channel entrance unit from revolving. At the same time, by means of the knurled knob 117, shown just above, pull plunger 116 fully down to clear the

hardened shoe 108. Then continue to press down on the matrix tray, being careful that the guide pin 119 is sliding under the shelf of the cam 120 until the stop pin 122 banks on the shelf of the channel entrance bracket.

The above procedure permits partial opening of the channel entrance without revolving the distributor bars, thus permitting the removal of clogged matrices without injury to the mechanism or matrices.

**Revolving the Channel Entrances**—On each distributor bar there is fastened a small bracket, containing two adjusting screws, and a flat steel spring with a curved end which snaps over a stud fastened to the distributor beam. When either of the two distributor bars is rotated into position the curved end of the flat spring snaps over the stud to hold the distributor bar in place.

The front screw in the bracket fastened to the distributor bar is for the purpose of adjusting the distributor bar to align with the distributor box, and the top screw should be set so it will just rest against the stud and serve as an additional support for the distributor bar.

The distributor bar with the 72-tooth combination has an additional lock to prevent any upward movement of the distributor bar. This lock is formed by the distributor bar retaining lever.

When the 90-tooth combination distributor bar is in the locked position, the

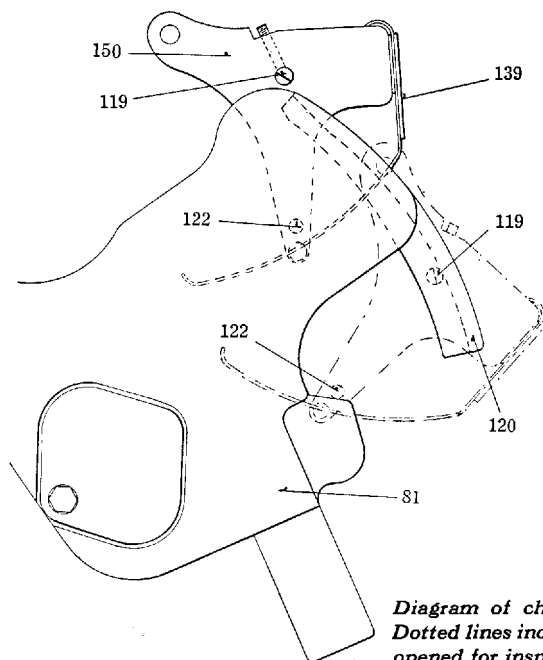

*Diagram of channel frame in operating position. Dotted lines indicate position of channel frame when opened for inspection.*

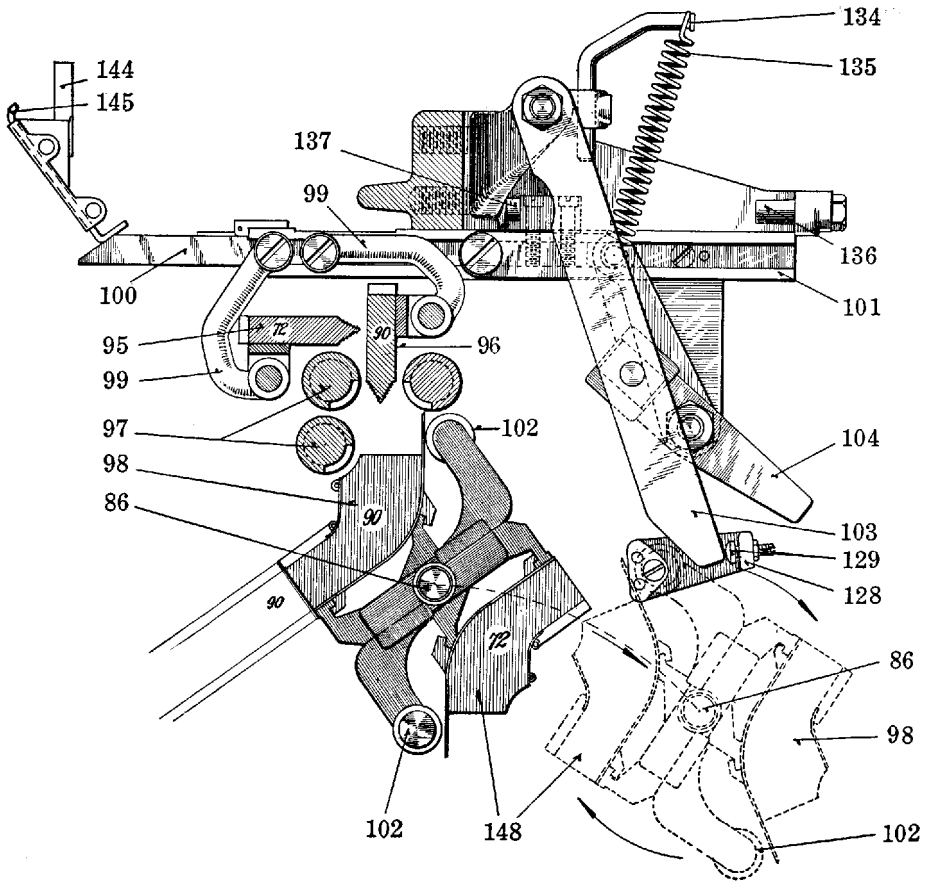

*Diagram of channel entrance unit and distributor bars in position for 90-character operation. The dotted outline of the channel entrance unit indicates its travel to change from 90- to 72-character operation.*

banking screw 137, see illustration just above, should be adjusted to bear easily against the banking block which is fastened to the slide 100. When the distributor bars are reversed, adjust the banking screw 136 similarly. In shifting the distributor bars, these screws act as shock absorbers to reduce the strain on the stud against which the distributor bars are locked.

This same diagram shows two rolls 102 which are attached to the end of the channel entrance unit. While the entrance is completing its revolution, one of these rolls presses against one or the other of the upright levers 103 or 104, and shifts the distributor bar to correspond with the channel entrance. These rolls are mounted on eccentric pins and should be adjusted to carry the slide 100 easily against the banking studs without undue strain.

### Mixer Distributor

The distributor clutch on Mixer Linotypes, while slightly different in detail, has the same action as the one used with single distributor model machines, previously described.

The illustration just below shows a back view of the upper distributor box on Mixer Linotypes. The matrix lift 7 is adjusted by means of the adjusting screw 15 in the same manner as on the single distributor models. The matrix lift lever return spring is shown at 14, and 9 is the matrix lift spring. The cushion-spring 16 allows the vertical portion of the matrix lift lever to sepa-

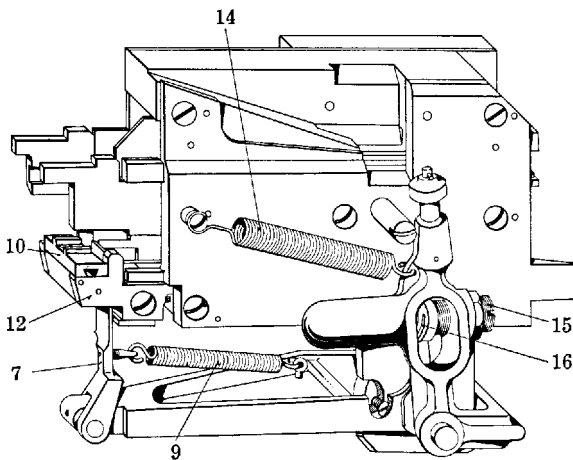

*Back view of the distributor box, upper, on Mixer Linotypes. This distributor box is similar to the box used on the single distributor machines except that it is equipped with the bridge support 12 which bears the matrix bridge 10.*

rate from the adjusting screw 15 if a matrix should be turned backward, or if there should be some obstruction preventing the matrix lift from rising.

The instructions for the adjustments and general care of the upper distributor box are essentially the same as for the single distributor box.

The illustration on page 154 shows a front view of the lower distributor box, showing the means of adjusting. To operate correctly the box must be kept clean, particularly the inside surface of the separating block 18 and the edges of the rails 32 and 33, as the matrices pass down over these rails by gravity only, and gum or oil will retard their movement.

The matrix pusher is operated by an end cam 26 and it must slide freely in its bearings. If it is sluggish, clean the rod and oil lightly, but do not tighten the

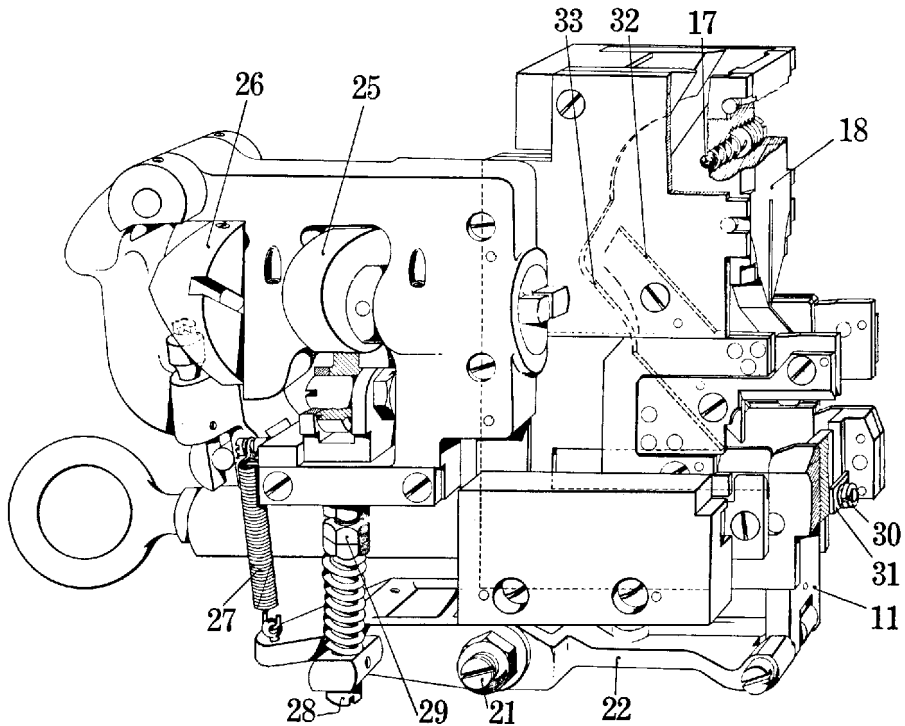

*Front view of the distributor box, lower, on Mixer Linotypes.*

return spring. If the tension of this spring is too strong it will cause excessive wear on the distributor screw gears. If there is lost motion in the matrix lift lever 22 it can be taken up with the adjusting screws 21. These screws have pointed ends and should be turned evenly so as not to cause a side bind on the matrix lift 11.

**Adjusting the Matrix Lift**—The matrix lift is operated by the cam 25 and should lift the matrices so the upper lugs pass freely over the distributor box rails, and this adjustment is made with the screw 28 after the lock nuts 29 are loosened. If the matrices are not lifted high enough, loosen the adjusting screw, or tighten the adjusting screw if the matrix lift is to be lowered. When the adjustment is correctly made, tighten lock nut. The matrix lift on the lower distributor box is flat at the top, and it must be adjusted so that it will not lift more than one thin matrix at a time. A special wrench (part No. G-3157) is needed when making this adjustment.

The lock nuts on the matrix lift adjusting screw are shown at 30, and under the nuts there is a thin square washer 31. When the adjustment is being made, place two thin matrices together in the box and adjust the lift until it will not

raise the second matrix. It is advisable to rub a drop of oil occasionally on the surface where the square washer travels.

*Timing the Lower Distributor Box*—The lower distributor box should be timed to receive the matrix from the upper distributor when the matrix pusher is in a certain position, and the timing is done in the following manner: Remove the distributor driving belt, then disconnect the idler gear, by removing the stud, which will leave the distributors independent of each other. Turn the lower distributor by hand in its regular direction until the matrix pusher comes all the way ahead; continue to turn until the matrix pusher prongs are about  $\frac{1}{8}$ " away from the distributor box rails and leave it in that position. Run a matrix through the upper distributor box and then turn the distributor screws very slowly and watch the matrix. At the instant it drops from the distributor box rails into the lower box, stop turning and connect the two distributors with the idler gear, being careful not to move the other gears.

The separating block 18 is held in place in the distributor box with a detent ball 17, and spring. If matrices should clog in the box and extend up into the chute, loosen the distributor box fastening screw and pull out on the box. This will remove the separating block from the box and the matrices can easily be removed. To start the distributor after it has been cleared of matrices, turn backward slightly on the knurled knob of the distributor clutch, pull the knob outward to allow the clutch blocks to spring into position.

It rarely happens, but it is possible for the springs 9 and 14 in upper distributor box, and the spring 27 in lower distributor box, to become weakened or damaged. If this should happen, the springs should be replaced.



---

## DRIVING

---

*Removing the Driving Shaft*—The illustration on page 158 shows a sectional view of the driving shaft, and also the pinion driving gear 13. If this gear becomes worn it should be replaced, otherwise it will impart an uneven motion to the main cam shaft. To replace this gear it will be necessary to remove the driving shaft. First take out the screw 9 which holds the toggle link collar 7 to the clutch rod 8. Then loosen the binding screw in the friction clutch arm 2 and slide the arm off the driving shaft. Next, slide the motor gear driving pulley off the driving shaft. On the late model machines the motor gear driving pulley construction consists of two sections, making it necessary to first remove the motor gear driving pulley from the motor gear driving pulley hub by withdrawing the four screws from the center flange of the motor gear driving pulley. Then unscrew the threaded bushing 12, which will release the spring 10.

It will also be necessary to disconnect the flange 15. This is held in place by a screw 14 which passes through a slot in the driving shaft, and also through a hole in the end of the clutch rod 8. Before the screw 14 can be taken out, a cotter pin in its end must be removed. Drive out the tapered pin 61 and force the driving shaft away from the pinion gear 13. If the shaft is hard to loosen, soak with kerosene before driving apart with a pig of type metal. Remove the tapered pin 62 from the collar 63 and the pinion gear will slide out.

When the driving shaft is reassembled, connect the pinion gear to the driving shaft before fastening the end collar 63. Have the machine in normal position and fasten the friction clutch arm temporarily to the driving shaft. When the pinion gear is meshed with the main driving gear, see that the friction clutch arm is parallel with floor. If clutch arm should be in a vertical position when machine comes to rest, it will cause friction and excessive wear on one clutch leather.

When shaft is in correct position fasten the collar 63 and put screw 14 through the flange 15, making sure that the screw passes through the hole in the end of the clutch rod 8. Replace compression spring and turn adjustable bushing into place.

*Do not use belt grease, rosin or dressing of any kind on the clutch leathers to make them pull. If the clutch slips, it may be that the rollers on the justification levers do not turn freely on their pins, or perhaps the main bearings of*

the cam shaft are gummy or not properly lubricated. If the main shaft does not turn freely, run a wire through the grease cup and pour kerosene into the opening made. This will remove any gummy substance which may have collected; then follow up with machine oil. Grease cup should then be filled and its cap screwed into place.

If the compression spring should become too weak to pull the machine, it is best to replace it with a new one. In case of emergency, the old one may be stretched—be careful to get the same amount of spread between each coil.

*The Friction Clutch Arm*—There are four  $\frac{1}{4}$ " pins 60, where the toggle links 6 are connected to the friction shoes 3 and the link collar 7. If these pins are worn, they should be replaced; otherwise the clutch leathers will have to be thicker than the regular size to give the proper  $\frac{1}{3}\frac{1}{2}$ " clearance between the flange 15 and the edge of the bearing 19. The rods 23 on the friction shoes 3 should be oiled slightly. This will allow the clutch to expand evenly.

*Clutch Collar Clearance*—Before this measurement is taken, *shut off the power*, turn the cam shaft backward and pull out on the starting lever. Then measure the distance between the flange 15 and the bearing 19. It should be  $\frac{1}{3}\frac{1}{2}$ " as shown in the illustration on next page.

*Friction Clutch Leathers*—If the various parts of the clutch friction arm 2 are not worn, the approximate thickness of the leather buffers should be about .125"; but if the  $\frac{1}{3}\frac{1}{2}$ " clearance before mentioned cannot be obtained using leathers of that thickness, it may be necessary to put thin strips of cardboard between the leathers and the ends of the shoes 3 to which they are fastened.

The circular wire brush for cleaning matrices can also be used to advantage in cleaning the clutch leathers. It leaves a good gripping surface and removes very little from the body of the leathers. The leathers can also be cleaned by scraping with a knife or by rubbing with coarse sandpaper.

The use of home-made leathers is not recommended. The leathers furnished by the Linotype Company are of the correct material and proper thickness. After new clutch leathers have been put on, it is advisable to check the vise automatic to see that the adjustment has not been changed.

*Driving Pulley*—The inside rim 20 of the driving pulley 22 must be kept clean, and the clutch leathers must be dry and free from gum. Also see that the heads of the screws 5 in the leathers 4 are below the surface of the leather, so they cannot come in contact with the inside surface of the driving pulley.

The pulley must turn freely on the driving shaft. There is a grease cup on the hub of the pulley and this should be turned down occasionally to lubricate the driving shaft. Do not use an excessive amount of grease as it might get on the friction clutch leathers and cause them to slip.

**The Vertical Lever**—The vertical lever may be removed as a unit for inspection or repairs. (See illustration on page 159.)

To remove the vertical lever from the machine, push in on the starting lever and turn the main cam shaft backward a short distance, then remove the upper bracket screw 64, and the entire unit may be lifted out. If necessary to replace either the upper stopping lever 26 or the lower stopping lever 27, loosen the set screw 32 in the upper bracket 31. Then the rod 28 with the stopping levers may be passed through a slot in the bottom of the vertical starting lever 51. The stopping pawls 26 and 27 are fastened to the shaft 28 with the fulcrum pins 29 and 30. If these pins become worn they should be replaced to take up the side play of the stopping pawls so that a closer setting may be made on the automatic starting and stopping pawls.

As shown, 56 is an adjusting screw, and on its end there is a spring 57 which holds the vertical lever lug against the stop screw 58.

When a line is being recast the eccentric screw 52 is brought in contact with the lower arm 55 of the vertical lever 51, and forces the automatic starting

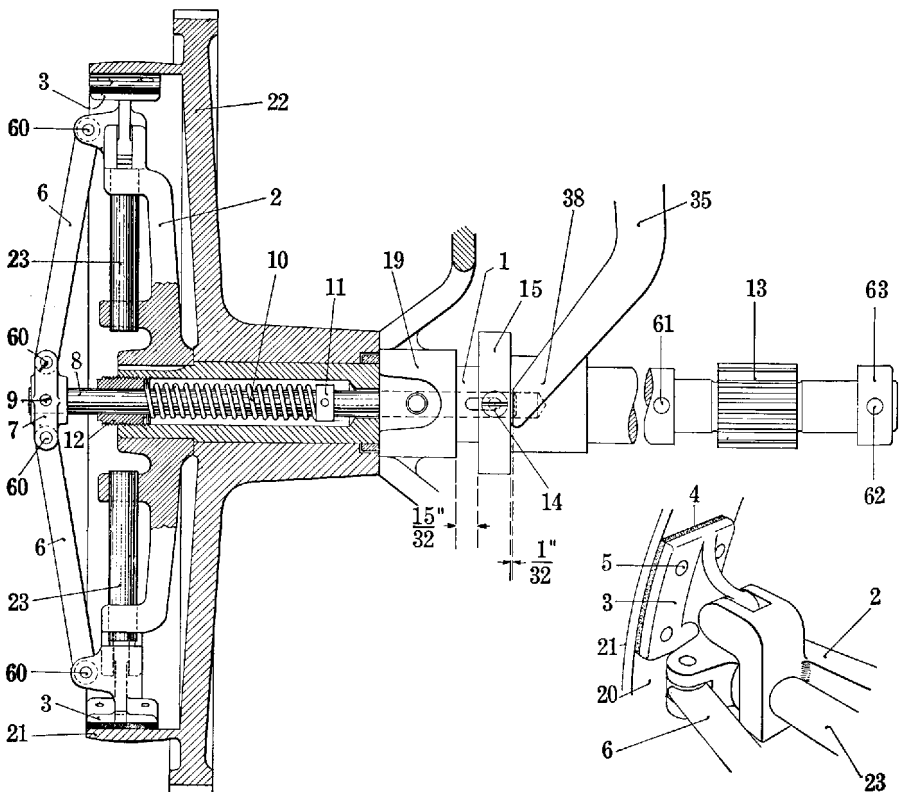

*View, partly in section, through the clutch end of the driving shaft.*

and stopping pawl 25 from the stopping lever 26 to allow the clutch to come into operation. The spring 57 must be strong enough to bring the vertical lever into place when the pressure is released from the starting lever handle.

The end of the adjusting screw 33, where it comes in contact with the lower stopping lever 27, should be well lubricated, as there is a sliding movement at this point each time the machine comes to normal position. The adjustment for the  $\frac{1}{32}$ " clearance between lower end of lever 27 and forked lever 35, is made with adjusting screw 33.

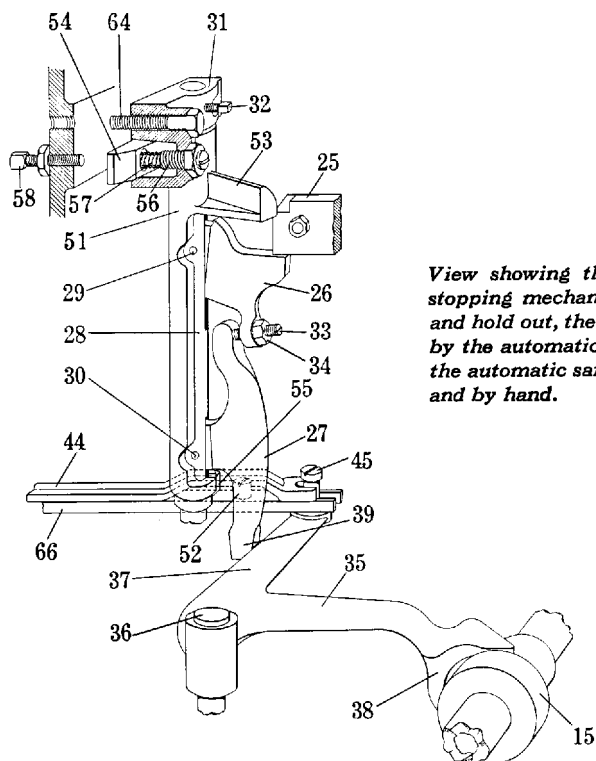

View showing those parts of the starting and stopping mechanism which serve to throw out, and hold out, the driving clutch when acted upon by the automatic starting and stopping pawl, by the automatic safety pawl, by the vise automatic and by hand.

**Testing Clearance of Forked Levers**—To make this test, *shut off power*, turn the cam shaft backward, pull out the starting lever handle, and see if the lower stopping lever 27 is free to be moved slightly where it rests against the arm 37 of lever 35. If it binds against this lever, loosen the adjusting screw 33 until there is a slight shake to the stopping lever 27. If there is too much clearance, tighten the set screw 33; otherwise the machine will have a tendency to slightly overrun when it comes to normal position.

**Failure of Clutch to Disengage**—It sometimes happens that the machine will “run away,” that is, the main cam shaft will not stop when the machine

comes to normal stopping position, due to failure of the clutch to disengage, especially after the starting lever handle has been pulled out to recast a line.

The following conditions may be responsible if this should happen: The spring 57 which returns the vertical lever to its position may be broken or too weak. Metal chips may have collected between the starting lever handle link and the connecting rod, causing it to bind; or the lever may not be free in its bearings. The inside rim of the driving pulley may be sticky, and there may be gum on the clutch leathers. Driving pulley may not be free on the driving shaft due to insufficient lubrication. It is also possible that the upper edge of the stopping lever 26 has become rounded where it comes in contact with automatic starting pawl.

The contact surfaces of the cams should be kept clean. If gum is allowed to accumulate it will interfere with the free turning of the justification lever cam rolls and may cause flat spots to be worn on them.

The cams should be cleaned occasionally and an easy and safe way to do this is to use a flat stick of wood with a rag wrapped around its end. Soak the rag with kerosene and hold it against the cam surfaces as they revolve. After the cams have been cleaned, wipe off with a dry rag. Use of the stick will prevent danger of getting the fingers caught. The use of machine oil on the cams as a lubricant is not recommended.

A felt wiper which is fastened to the side of the mold turning gear cover, is for the purpose of lubricating the hardened shoes on the mold turning bevel pinion, and should carry a small amount of oil.

---

## LINOTYPE ADJUSTMENTS

---

The fifty most important adjustments on the Linotype have been assembled here for quick reference. These adjustments are arranged in the same sequence as the machine operations.

For a more complete, authoritative discussion and explanation of all the Linotype mechanisms, the "Linotype Machine Principles" text book is recommended. Every plant should have this official manual. This 487-page text is profusely illustrated with simple drawings of every adjustment and part of the Linotype. "Linotype Machine Principles" will be mailed postpaid to any place in the United States for \$4.05.

## Assembling

1. *Keyboard Upper Guide*—When placing keyrods in guides be sure to notice whether machine is equipped with double “e” attachment; if not, leave first section of upper guide blank.
2. *Matrix Delivery Belt*—To be kept tight. Adjust by pulling idler pulley back. This belt carries the matrices from the assembler entrance to the assembling elevator.
3. *Assembler*—The chute spring to throw the bottom of the matrices toward the star wheel, allowing the cap “W” to go between it and the rails. Adjust by finger adjustor stud. (No adjustment on Blue Streak machines.) The star wheel shaft to have a spring with the proper tension, to slip on tight lines. The catch spring to prevent matrices from falling backward. Adjust by bending spring so it will be flush with casting when pushed by matrices. Newer machines have star wheel friction adjustable from front of assembler.
4. *Assembler Slide Brake*—To release just before the line delivery starts. Adjust by screw in operating lever. This brake holds the slide when the line is being assembled and releases to bring slide back into position. The outer end of the operating lever is forced up by the assembling elevator when it is raised and releases the brake. When the elevator descends, the lever is forced down, setting the brake for another line.
5. *Assembling Elevator*—Starting pin to release the delivery slide just as the latch catches. Adjust by screw under starting pin. This small pin starts the machine by releasing the delivery slide, which is carried to the first elevator by line delivery spring, bringing roll on split lever in contact with the automatic stopping pawl, forcing the pawl off the upper stopping lever and allowing the clutch to go into action.
6. *Assembling Elevator*—To be returned by its own weight. Adjust by counterbalance spring screw hook in keyboard frame. This is to make the elevator fall easily by balancing it so that it will just fall into position.
7. *Spaceband Box*—The pawls to go  $\frac{1}{2}$ " below the box rails on the down stroke. Adjust by screw in pawl lever. The pawl lifts the spacebands over the rails, allowing them to fall into the assembler.
8. *Spaceband Box Center Bar*—One spaceband should be released at a time. Adjust by screw in center bar. This allows but one spaceband to pass between it and the points of the spaceband box rails.
9. *Spaceband Lever*—The spaceband lever pawl should pass point of spaceband box rails. Adjust by turnbuckle that connects with the transfer lever. This lever returns the spacebands to their box.

10. *Delivery Slide*—The slide should go far enough back to just catch in the second notch of the delivery pawl. Adjust by split lever on shaft. This is to bring the delivery slide back so that when a line is raised by the assembling elevator, the line will not strike the delivery slide short finger.

11. *Delivery Slide*—To stop  $\frac{1}{8}$ " inside of first elevator. Adjust by stop screw on face plate. This adjustment is to carry the matrices inside the first elevator retaining pawls, which keep them from falling out.

12. *Delivery Slide*—To start the machine when the slide stops against the stop screw on face plate. Adjust plate on automatic pawl. The starting of the machine is done by the delivery roller forcing the automatic stop pawl off the upper stopping lever.

### Casting

13. *First Elevator*—To just clear the transfer and delivery channels. Adjust by gibs on vise frame. The elevator carries the line to the mold, and after the cast, carries it up to the transfer channel.

14. *First Elevator Connecting Link*—Allow  $\frac{3}{4}$ " at the top and  $\frac{1}{8}$ " at the bottom from holes to shoulders. Adjust by link screws. The link has a spring inside of it that compresses when the alignment is made. Then adjust first elevator jaws a hair line lower than grooves in line delivery channel by screw in auxiliary lever.

15. *First Elevator*—Allow .010" between adjusting screw and vise cap when first elevator is lifted for alignment. When using display matrices in 45-point alignment or auxiliary position of duplex display matrices, this setting should be about .005". Adjust by center screw at top of elevator when matrix toes are in the mold. This alignment of matrices is important.

16. *First Elevator*—Adjust jaws a hair line higher than transfer channel so that the matrices will pass freely to the second elevator. Adjust by screw on bottom of first elevator slide, right side. Also adjust from front to back.

17. *Mold Turning Cam*—The steel shoes to take up lost motion in pinion. Adjust by screw bushings in cam. This is to position the mold disk in casting and ejecting position so locking studs will enter bushings.

18. *Mold Turning Bevel Pinion*—Set screw to be on top when cams are in normal position. The pinion turns the mold disk and gets its power from the segments in the cam. The short segment gives one-quarter turn, bringing the mold to casting position; the long segment gives three-quarters turn, carrying the slug past the back knife, which trims the slug to type-high; then it goes to ejecting position.

19. *Mold Disk Locking Stud Blocks*—Disconnect the mold slide and pull the disk forward on the locking studs to see that they do not bind, and also see that the ejector blade is in line with the base of the mold when the blade comes forward. If the blade does strike, or the locking studs bind in the stud block, it may be necessary to remove the dowel pins from the blocks and fasten them loosely to the vise frame; then see that the ejector blade is in correct relation to the mold. Tighten the stud blocks evenly so that the locking studs will be free in the blocks.

20. *Gibs on Vise Frame*—Adjust first elevator so elevator will stand square with mold. Test by placing a thin matrix in each end of first elevator jaw, pull mold forward over toes of matrices, raise elevator by hand. If matrices are tight, alignment is correct; if not, adjust gibs. The jaw will be partially self-aligning if there is some play between the slide and the lower gibs.

21. *Mold Slide*—To bring mold slide .003 to .005" from vise jaw or line. Adjust eccentric pin in mold slide lever (pin with lever attached). This is to bring the mold over the toes of the matrices so that the alignment can take place. The mold must not strike the line of matrices or it will prevent proper justification.

22. *Mold Driving Pinion Shaft Friction Clamp*—To take up lost motion in the mold disk. Adjust screw in clamp. This is to keep the disk from running past the locking stud blocks.

23. *Vise Automatic Disk Dog or Plunger*—To just clear the automatic stop rod. Adjust by screw at right on top of elevator slide. Machine to be stopped by thin space placed under center screw of first elevator. This is to stop the machine in case the first elevator does not come down to proper position. The disk dog pushes against the automatic stop rod, forcing it out; the bottom end, coming in contact with stop lever, acts on the connecting rod, which, in turn, pushes the forked lever against the collar that is connected to one end of the clutch rod, the other end of the rod being connected to the clutch. This causes the clutch to be thrown out of action and stops the machine.

24. *Vise Jaw*—To bring face of type flush with each end of the slug. Adjust screw bushing in bracket for left-hand long jaw and screw on knife block for right-hand jaw. This positions the type on slug with no indention or overhang.

25. *Metal Pot*—Mouthpiece holes to align with smooth side of slug. Adjust with top and bottom screws in pot legs. Square pot with front and back screws when using gauge.



26. *Pot Lever Eye Bolt*—There should be  $\frac{3}{16}$ " between the nut and pot lever when spring is compressed. All late model machines have pipe riveted to the screw, and nut should be against pipe. This gives the lockup to the pot and takes up all excess friction.

27. *Pump Stop*—To have  $\frac{1}{8}$ " between stop lever and stop. Adjust by screw in pump stop operating lever. This mechanism prevents a line from casting if it is not properly justified.

28. *Thermostat Gas Governor*—To lower temperature, turn the dial to the left; to raise temperature, turn dial to the right. The tubular casing part of the thermostat which is immersed in the metal is machine steel and has a pocket in the bottom of the tube in which is set an Invar steel rod. Invar is a high nickel content steel which has about one-tenth the coefficient expansion of machine steel. The contraction or expansion of the thermostat casing lowers or raises the Invar rod which in turn operates the levers that control the plunger type of gas valve.

29. *Back-Knife*—To set square and press lightly against the mold. Adjusted by two square-headed screws back of the knife. The slug passes in front of the knife, which trims it to type high.

30. *Trimming Knives*—To trim the slugs to size and parallel. Adjust left-hand knife to trim overhang from smooth side of slug. The knife is held to the vise frame with two square-headed screws, and there are two side adjusting screws in the knife block against which the knife rests. The right-hand knife is held by two hexagon-headed bolts and two micrometer-set screws.

31. *Ejector Blade*—When the blade advances it should come slightly beyond the front end of the lower liners in the knife block. Adjust by screw in ejector lever pawl. This is where the slug is pushed out of the mold between the trimming knives and into the galley.

### Distribution

32. *First Elevator Slide Guide*—Releasing lever to clear transfer slide  $\frac{1}{8}$ ". Adjusted by screw in second elevator. This lever is to keep the matrices from transferring if the second elevator does not come down in position.

33. *First Elevator Intermediate Bar*—When pawl is raised it should be flush with second elevator bar. Adjust by two screws in top cap. This pawl is to push down the spacebands when transferring.

34. *Elevator Transfer Lever*—Allow  $5\frac{5}{8}$ " from the intermediate or transfer channel to slide finger ( $7\frac{5}{8}$ " on 42-em machines). Adjust by moving split lever on shaft. This is the lever that transfers the line from the first elevator to the second elevator.

35. *Transfer Slide*—Allow  $\frac{1}{8}$ " between slide finger and the end of slot in spaceband lever pawl. Adjust screw in transfer slide. The slide and finger push the spacebands under the pawl to return them to their box.

36. *Transfer Slide*—Cut in slide finger to be flush with right-hand end of first elevator back jaw. Adjust by screw in automatic safety pawl. This is when the line is transferred to the second elevator bar. The cam roller works the automatic safety pawl buffer, which forces the pawl clear of the upper stopping lever.

37. *Second Elevator*—When the elevator is at transfer point, roller should be free of cam. Adjust by connecting bolt in second elevator lever. This is to assure the elevator going to its proper position for the line to transfer. When elevator is at upper position the connecting bolt should be loose. When elevator is at transfer point the second elevator starting spring should be flush with collar. On older models adjusting nut should touch spring. This spring is to start the elevator down and prevent sticking at the distributor box.

38. *Distributor Box*—The matrices should pass freely from the box rails to the distributor bar. Adjust by the screws in the top of the distributor bar. The matrices travel along this bar until they come to their proper places, when they drop through the channel entrance into the magazine.

39. *Distributor Box Lift*—To lift matrices  $\frac{1}{32}$ " above rails in the distributor box. Adjust by screw in cam lever. This lifts the matrices into the distributor screws, one at a time.

40. *Distributor Beam*—Adjust distributor beam vertically so that the bottom of a matrix will clear the top of the channel entrance partitions by about .043".

41. *Distributor Screw Matrix Guard*—The matrix guard to be adjusted to clear the distributor screws. There must be clearance between matrix guard and matrices as they pass along the distributor bar.

42. *Matrix Guard Safety*—On "Two-in-One" single distributor machines, adjust the lower end of distributor screw matrix guard lever so that if there are matrices on the distributor bar, the channel entrances or distributor bars cannot be changed until all matrices are distributed.

## Driving

43. *Main Clutch*—Allow  $\frac{1}{32}$ " between the collar and the machine bearing. This is where the power is applied and it is connected to the cam shaft by gears that are 11 to 1, and give one revolution of the cams to 11 of the clutch.

44. *Automatic Pawls*—(Stopping and Safety)—Set  $\frac{1}{16}$ " from the edge of the cam. Use adjusting screw in automatic pawls—the screws that go through the pawls and strike on the lugs of the cam. The stopping pawl is to stop the machine after it has made one revolution. The safety pawl is to stop the machine if for any reason the line has not transferred.

45. *Automatic Stopping Pawl*—Set  $\frac{1}{4}$ " on upper stopping lever. Use set screw in top of vertical lever. This pawl is for stopping the machine in normal position. The action is to push down on the upper stopping lever, forcing the lower stopping lever against the forked lever, which in turn pushes against the collar fastened to the clutch rod, the other end being connected to the clutch. In doing this, the clutch is thrown out and the machine is stopped.

46. *Lower Stopping Lever*—Allow  $\frac{1}{32}$ " between the lower stopping lever and forked lever. Use adjusting screw in upper stopping lever. This lever is the connection between the upper stopping lever and the forked lever to get a horizontal motion from a vertical action.

47. *Vertical Lever*—Should force automatic pawls  $\frac{1}{16}$ " clear of the upper lever. Use adjusting screw in outside of vertical lever bearing to tighten spring. This lever is only in action when starting lever is pulled by hand. The eccentric screw in the starting rod, pulling against the lower lug of the vertical lever, forces it around, causing the upper lug to push off the automatic pawls, which releases the clutch letting the machine go into action.

48. *Vertical Lever*—Allow  $\frac{1}{16}$ " between the upper lug and automatic stopping pawl. Use adjusting screw inside of column. This lever is returned by a spring and stops against the adjusting screw and should move freely.

49. *Starting Lever*—Allow  $\frac{1}{32}$ " between eccentric screw and vertical lever lower lug. This lever controls the machine. When part way out and standing free, machine is in operative position; pulled out it will start machine.

50. *Tie Rod*—The tie rod consists of a long bolt which passes through a projection on the top of the main cam shaft bracket cap and extends into the column of the machine. The head of this bolt should bear snugly against the cam shaft bracket cap when the machine is in normal position. The tie rod takes up the strain when the pot locks up.

## INDEX

---

# INDEX

---

- Adjustments, Fifty Important, 160
- Assembler, Adjustments, 161
- Assembler, Assembler Entrance, 84
- Assembler Slide, 87
- Assembling Elevator, 88
- Automatic Pump Stop, 115
- Automatics, Spiral, 144
- Back Knife, Adjusting, 105
- Back Knife, Sharpening, 106
- Back Squirts, 114
- Bar, Distributor Box, 141
- Bar, Second Elevator, 136
- Big Scheme of Simple Operation, 5
- Box, Distributor, 140
- Box, Spaceband, 81
- Casting, 94
- Casting, Adjustments, 162
- Channel Entrance, 148
- Channel Entrance, Opening, 149
- Channel Entrance, Revolving, 151
- Charts, Oiling, 52
- Cleaning Matrices, 45
- Cleaning Spacebands, 81
- Clutch Arm, Friction, 157
- Clutch, Distributor, 146
- Clutch, Driving, 159
- Clutch, Driving, Clearance, 157
- Clutch Leathers, Friction, 157
- Conservation of Matrices, 49
- Delivery Slide, Line, 90
- Distribution, 132
- Distribution, Adjustments, 164
- Distributor Beam, Adjustment, 144
- Distributor Box, 140
- Distributor Box Bar Point, 141
- Distributor Box, Lower, Timing, 155
- Distributor Box Rails, 141
- Distributor Box, Testing, 142
- Distributor Clutch, 146
- Distributor, Mixer, 153
- Distributor Screw, Back, 143
- Distributor Shifter and Slide, 138
- Distributor, Single, 139
- Distributor, Two-in-One, 149
- Doublets, 73
- Driving, 156
- Driving Adjustments, 166
- Driving Clutch, 159
- Driving Pulley, 157
- Driving Shaft, Removing, 156
- Ejection of Slugs, 123
- Ejector Blades, Replacing, 124
- Ejector Lever, Adj. Stop Pawl, 125
- Ejector Lever, Adjusting Stroke of, 125
- Ejector Slide, Removing, 123
- Electric Pot, 117
- Elevator Jaws, 97
- Elevator Jaw Line Stop, 98
- Elevator Slide, 98
- Elevator Slide and Jaw, 94
- Elevator Slide Safety Stop Plate, 98
- Escapement, 77
- First Elevator Jaws, 97
- First Elevator Jaw Line Stop, 98
- First Elevator Slide, 98
- First Elevator Slide and Jaw, 94
- First Elevator Slide Safety Plate, 98
- Font Distinguisher, 143
- Forked Levers, 159
- Friction Clutch Arm, 157
- Friction Clutch Leathers, 157
- Gas Pot, 117
- Gas Pot Thermostat, 121
- Hairlines, Prevention, 44
- Jaws, Vise, 100
- Justification, 100
- Justification, Imperfect, 101
- Justification Rods and Bar, 101
- Justification Wedge, 100
- Keyboard, 74
- Keyboard Key Levers, 77

- Keyboard, Reassembling, 77  
Keyboard Rubber Rolls, 75  
Knife, Back, Adjusting, 105  
Knife, Back, Sharpening, 106  
Knife Block, 127  
Knives, Side, Adjusting, 127  
Knives, Side, Sharpening, 131
- Line Delivery Slide, 90  
Line Stop, 98  
Lockup, Testing, 111  
Lubricants, Approved, 51  
Lubrication, 51, 102, 148
- Magazine, 80  
Maintenance Schedules, 66  
Matrices, Care and Maintenance, 41  
Matrices, Cleaning, 45  
Matrices, Do and Do Not, 49  
Matrices, Doublets, 73  
Matrices, Failure to Drop, 72  
Matrices, New, 46  
Matrix Lift, 141  
Matrix Lift, Adjusting, 142, 154  
Matrix Lugs, Repairing, 43  
Matrix Teeth, 42  
Matrix Transpositions, 73  
Mechanical Thermostat, 119  
Metal Pot, 109  
Metal Squirts, 95, 96, 114  
Metal Temperature, 123  
Micro-Therm Electric Controls, 117  
Micro-Therm Gas Control, 122  
Mixer Distributor, 153  
Mold Disk and Slide, 103  
Mold Disk Locking Stud Block, 108  
Mold Slide Adjustment, 48, 107  
Mold Slide, Removing, 109  
Mold Turning Mechanism, 103  
Mold Wipers, 109  
Molds, 102  
Mouthpiece, 110  
Mouthpiece Wiper, 117
- New Matrices, Treatment of, 46
- Oiling Charts, 52
- Plunger, Pot Pump, 113  
Pot, Electric, 117  
Pot, Gas, 117  
Pot, Metal, 109  
Pot Pump Lever Retaining Rod, 115  
Pot Pump Plunger, 113  
Pot Pump Spring, 115  
Pulley, Driving, 157  
Pump Stop, 115
- Quick-Drop Attachment, 117
- Rubber Rolls, 75
- Schedules, Maintenance, 66  
Second Elevator, 137  
Second Elevator Bar, 136  
Semi-Quick Drop, 117  
Single Distributor, 139  
Slide, Ejector, 123  
Slide, Line Delivery, 90  
Slide, Mold, 103  
Slide, Mold, Adjusting, 48, 107  
Slide, Mold, Removing, 109  
Slug, Stuck, Removing, 127  
Slugs, Ejection of, 123  
Slugs, Failure to Eject, 126  
Spaceband Box, 81  
Spaceband Lever Pawl, 136  
Spacebands, 81  
Spiral Automatics, 144  
Squirts, How to Remove, 95  
Squirts, Principal Causes, 96
- Temperature, Metal, 123  
Thermostat, Gas, 121  
Thermostat, Mechanical, 119  
Thermostat, Micro-Therm Elec., 117  
Thermostat, Micro-Therm Gas, 121  
Transfer, 132  
Transfer Alignment, 132  
Transfer Lever, 134  
Transfer Safety Pawl, 135  
Transpositions, 73  
Two-in-One Distributor, 149
- Vertical Starting Lever, 158  
Vise, 99  
Vise Automatic, 99  
Vise Jaws, 100
- Wipers, Mold, 109  
Wipers, Mouthpiece, 117

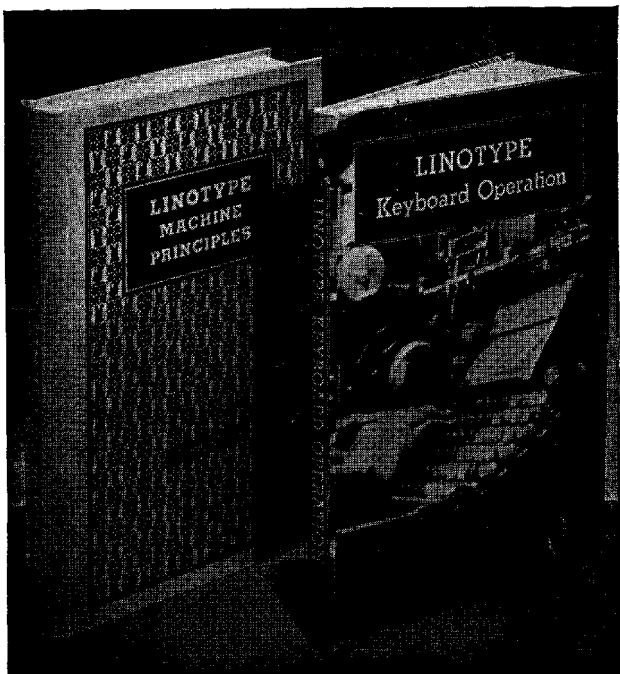

---

## Two Books Every Printer Needs

---

Every printer, operator, machinist, apprentice and student of printing should have *Linotype Machine Principles* and *Linotype Keyboard Operation*, official Linotype publications.

Revised and corrected, *Linotype Machine Principles* has been entirely rewritten and illustrated. Much of the technical information contained in the pages of *Linotype Maintenance Manual* has been taken from this authoritative book. It is a complete compendium of mechanical information concerning Linotypes.

All Linotype agencies have these books in stock. Order from your nearest agency. Either or both books (as desired) will come to you by return mail, post paid. Or, ask your Linotype Production Engineer about them.

# Linotype Machine Principles

EVERY MECHANISM of the Linotype (both Blue Streak and earlier models) is explained simply and thoroughly in this book. It is the result of two years' effort by Linotype engineers and technicians and has been carefully checked by independent machinists with

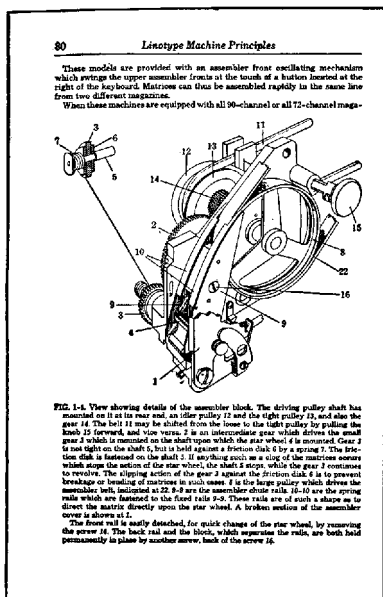

80 Linotype Machine Principles

These models are provided with an assembler from oscillating mechanism which springs the upper assembler frame at the touch of a button located at the right of the keyboard. Matrices can thus be assembled rapidly in the same line from two different magazines.

When these machines are equipped with all 90-channel or all 72-channel maga-

FIG. 1-4. View showing details of the assembler block. The driving pulley shaft has mounted on it its rear end, an idler pulley 12 and the tight pulley 13, and also the gear 14. The belt 11 may be shifted from the loose to the tight pulley by pulling the knob 15 forward, and vice versa. J is an intermediate gear which drives the small gear 2 which is mounted on the shaft 5, which the star wheel 4 is mounted. Gear 2 is not tight on the shaft 5, but is held against a friction disk 6 by a spring 7. The friction disk is fastened to the shaft 11. As the shaft 5 rotates, the gear 2 continues to revolve. The slipping motion of the gear 2 against friction disk 6 is to prevent the leakage or binding of matrices in such cases. It is the large pulley which drives the assembler belt, indicated at 22. 9-8 are the assembler drive rolls. 10-10 are the spring rolls which are fastened to the fixed rolls 7. These rolls are of such a shape as to direct the matrix directly upon the star wheel. A broken section of the assembler cover is shown at 1.

The front roll is easily detached, for quick change of the star wheel, by removing the screw 16. The back roll and the block, which operates the rolls, are both held permanently in place by another screw, back of the screw 16.

A page from *Linotype Machine Principles* showing the careful attention to detail that is characteristic of the whole book.

years of experience maintaining Linotypes in both newspaper and commercial plants.

*Linotype Machine Principles* has been arranged in the sequence of the basic operations of the machine. Included in this book are detailed descriptions of the new features of the Linotype together with instructions on their care and operation (Micro-Therm, Self-Quadder, Universal Precision Knife Block, and other Linotype features).

There are more than four hundred drawings in the thirty-six chapters of this new book, giving graphic explanation of most of the adjustments and methods of maintenance. Full cloth binding, 473 pages and a carefully detailed index with full information on Linotypes as recent as the Blue Streak Model 32.

*Linotype Machine Principles* can be purchased from any Linotype agency.

# Linotype Keyboard Operation

THE NEW EDITION of *Linotype Keyboard Operation* has been carefully revised, brought up to date and reset in Linotype Caledonia. This book has been written from the point of view of the operator and includes detailed discussions and explanations of most of the work he encounters.

It is profusely illustrated and provided with numerous examples of tabular work, run-arounds, food-store and many other unusual methods of composition. There are very few typesetting practices that the operator won't find fully explained in this carefully detailed book.

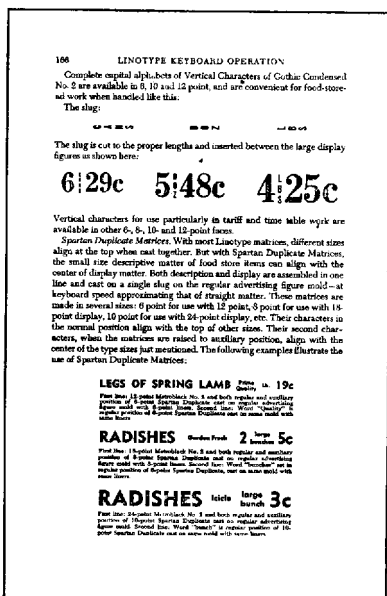

106 LINOTYPE KEYBOARD OPERATION  
Complete capital alphabets of Vertical Characters of Gothic Condensed No. 2 are available in 6, 10 and 12 point, and are convenient for food-store work when handled like this.

The slug:  
The slug is cut to the proper lengths and inserted between the large display figures as shown here:

6!29c 5!48c 4!25c

Vertical characters for use particularly in tariff and time table work are available in other 6, 8, 10- and 12-point faces.

Spartan Duplicate Matrices. With most Linotype matrices, different sizes align at the top when set together. But with Spartan Duplicate Matrices, the small size descriptive matter of food store menus can align with the center of display matter. Both descriptive and display are assembled in one line and set on a single slug on the regular advertising figure mold—at keyboard point approximating that of straight matter. These matrices are made in several sizes of point for use with 12-point, 9-point for use with 16-point display, 10-point for use with 24-point display, etc. Their characters in the normal position align with the top of other sizes. These characters, when the matrices are raised to auxiliary position, align with the center of the type sizes just mentioned. The following examples illustrate the use of Spartan Duplicate Matrices:

LEGS OF SPRING LAMB Price 12c

Per lb. 12 cents (Spartan) No. 1 and both regular and auxiliary position of 12-point (Spartan) Duplicate Matrices. 12-point (Spartan) Duplicate Matrices. 12-point (Spartan) Duplicate Matrices. 12-point (Spartan) Duplicate Matrices.

RADISHES Medium Fresh 2 large 5c

Per lb. 12 cents (Spartan) No. 1 and both regular and auxiliary position of 12-point (Spartan) Duplicate Matrices. 12-point (Spartan) Duplicate Matrices. 12-point (Spartan) Duplicate Matrices. 12-point (Spartan) Duplicate Matrices.

RADISHES extra large 3c

Per lb. 12 cents (Spartan) No. 1 and both regular and auxiliary position of 12-point (Spartan) Duplicate Matrices. 12-point (Spartan) Duplicate Matrices. 12-point (Spartan) Duplicate Matrices. 12-point (Spartan) Duplicate Matrices.

A page from *Linotype Keyboard Operation* which shows some of the hundreds of graphic demonstrations of composition styles.

*Linotype Keyboard Operation* is divided into four general classifications: Keyboard Practice; Commercial Composition and Book Work; Newspaper and Advertising Composition; and Equipment Information. With the detailed index, it contains 180 pages of information for every printer.

Because of its attractive cloth binding, this book should be in every printer's personal library, as well as being a good style reference.

*Linotype Keyboard Operation* can be purchased from any Linotype agency.