

LINOTYPE IMPROVEMENT SHEET

NO. 300

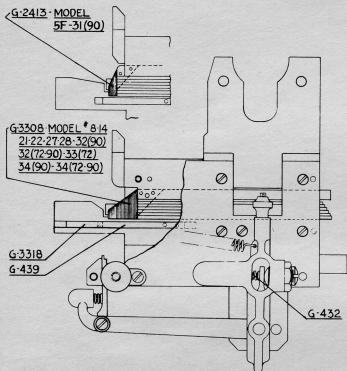

G-1579 MODEL # 5F
 G-3316 MODEL # 814-32(90)-32(72-90)-33(72)
 33(90)-33(72-90)-34(90)-34(72-90)
 G-3408 MODEL # 21-22-27-28
 G-3645 MODEL # 31(90)

OLD CONDITION

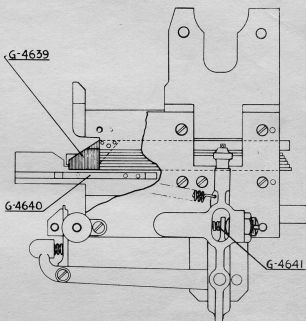

G-3316 MODEL # 814-31(90)-32(90)-32(72-90)
 33(72)-33(90)-33(72-90)
 34(90)-34(72-90)
 G-3408 MODEL # 21-22-27-28
 G-4642 MODEL # 5F

NEW CONDITION

UNIVERSAL DISTRIBUTOR BOX BAR POINT

A universal Bar Point (G-4639) has been adopted for use with all Single Distributor Machines. This Long Bar Point was designed to accommodate all width Matrices. In conjunction with this improvement a lighter Cam Lever Spring (G-4641) is used to prevent bending or breaking of Bar Point, also a single Rail Spring (G-4640) is used in place of the current Springs (G-3318 & G-439) to prevent twisting of matrices in the Distributor Box when Distributor Shifter is withdrawn.

APPLIED IN FACTORY TO MODELS

All new Model 5, 31, 32, 33, 34 Machines.

OUTSTANDING MODELS

Can be applied to all outstanding Model 31, 32, 33, 34 having the Long Bar Point, by substituting parts indicated, for Model 5, 31(4)(90) having the short Bar Point, it is necessary to substitute the Distributor Box (Assembled).

First applied to Model 31(4)(90) - Serial #62820

MERGENTHALER LINOTYPE COMPANY, Brooklyn, N.Y.

January 4, 1950

No. 300

Printed in U.S.A.