

Model 31

Cam Roll BB630
Anti Roll BB634
Pair BB632

BB754
1 5/16" wide
1/8" oversize

← Oversize Rolls
LINOTYPE IMPROVEMENT SHEET
NO. 307

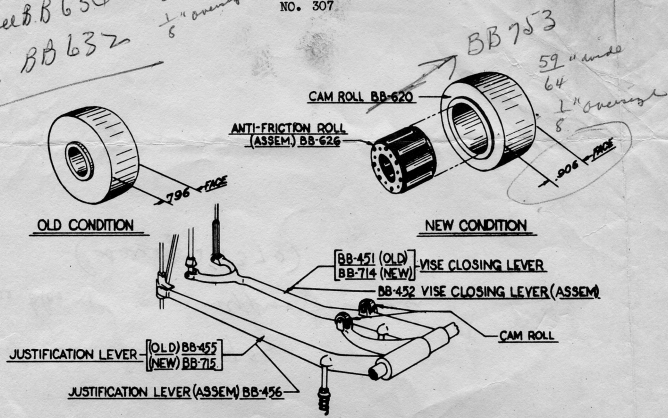

WISE CLOSING & JUSTIFICATION LEVERS (ASSEMBLED) (42EMS)

The width of the Cam Roll has been increased on both the Vise Closing & the Justification Levers to insure the roll riding on the full face of the cam and an Anti Friction Roller has been added.

APPLIED IN FACTORY TO MODELS

All current 42 Em Machines.

OUTSTANDING MODELS

Can be applied to all outstanding (42 Em) Machines by replacing the present Justification Lever (Assembled) & Vise Closing Lever (Assembled) with Justification Lever (Assembled) (BB-456 with Wide Roll) & Vise Closing Lever (Assembled) (BB-452 with Wide Roll) or by milling the Cam Roll slots in both existing Levers to .922 plus .002 minus .000 and replacing the present Cam Rolls with Cam Roll (BB-620) and Anti Friction Roll (Assembled) (BB-626).

First Applied to Model 31(4)(90) - Serial #63991 58370

MERGENTHALER LINOTYPE COMPANY, Brooklyn, N.Y.

February 14, 1951.

No. 307

Printed in U.S.A.