

LINOTYPE IMPROVEMENT SHEET

NO. 324

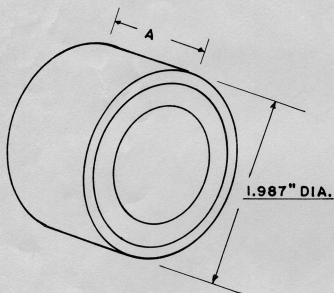

BB-620 A=.916"  
BB-630 A=1.072"

STANDARD ROLL

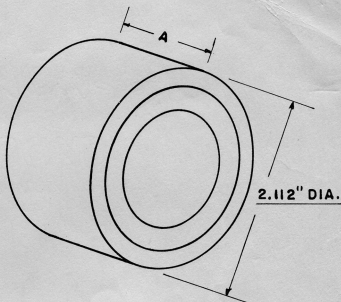

BB-753 A=.916"  
BB-754 A=1.072"

OVERSIZE ROLL

OVERSIZE JUSTIFICATION AND VISE CLOSING CAM ROLLS

OUTSTANDING MODELS

"Oversize" Justification and Vise Closing Cam Rolls (1/8 Inch oversize on diameter) have been made available for Outstanding Machines equipped with Anti-Friction Type Cam Rolls.

MERGENTHALER LINOTYPE COMPANY, Brooklyn, N.Y.

April 2, 1957

No. 324

Printed in U.S.A.