

LINOTYPE IMPROVEMENT INFORMATION SHEET

NO. 329

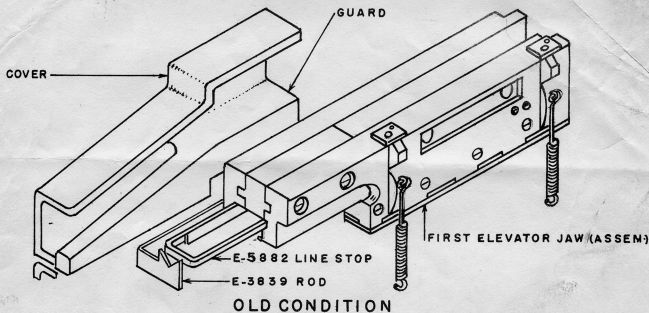

OLD CONDITION

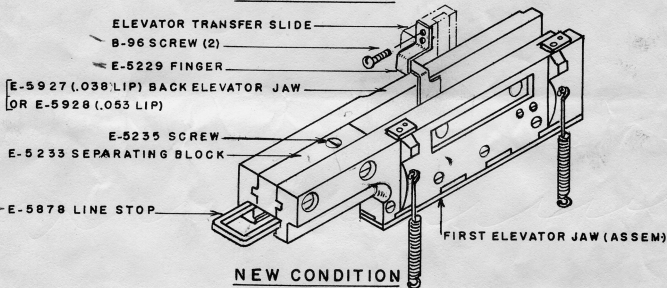

NEW CONDITION

FIRST ELEVATOR JAW LINE STOP E-5878

The type of automatic sliding line stop formerly used only on Comet Linotypes is now applied to all new Models 5, 29, 30, 31, 32, 33, 34, 35 and 36. This line stop has a projection which rides above the top of the first elevator back jaw. A small finger attached to the transfer slide, contacts this projection to return the line stop to normal position. This eliminates the former line stop return rod which projected from the end of the face plate and also its guard and cover.

OUTSTANDING MODELS

Can be applied to Outstanding Linotypes by using finger E-5229, two screws B-96, Line stop E-5878, first elevator back jaw E-5927 (.038 lip) or E-5928 (.053 lip), separating block E-5233 and screw E-5235. If the first elevator back jaw with detent for quadder machines is wanted, apply E-5939 (.038 lip) or E-5940 (.053 lip). See Improvement Sheet No. 327.

MERGENTHALER LINOTYPE COMPANY, Brooklyn, N.Y.