

LINOTYPE IMPROVEMENT INFORMATION SHEET

NO. 342

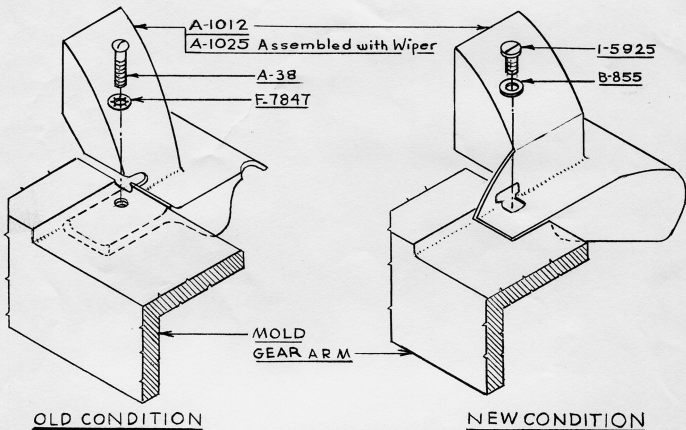

MOLD TURNING GEAR COVER, A-1012 (A-1025 ASSEMBLED)

This gear cover has been redesigned to eliminate the possibility of it shifting and to permit easier application. The redesigned cover is fastened to the top of the mold gear arm instead of the underside and is held in place by a I-5925 screw and a B-855 washer.

APPLIED IN FACTORY TO MODELS

All new machines.

OUTSTANDING MODELS

Can be applied to outstanding Linotypes by drilling and tapping a 5/16" x 18 hole in the mold gear arm and using one I-5925 screw with a B-855 washer

NO. 342