

LINOTYPE IMPROVEMENT INFORMATION SHEET

NO. 343

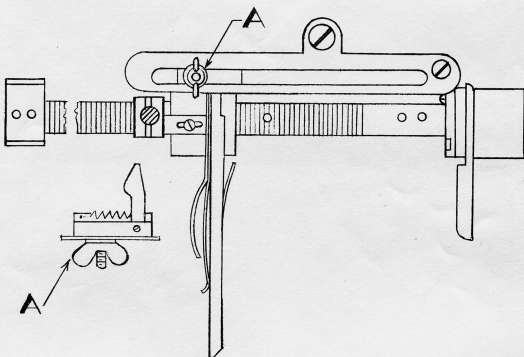

DELIVERY SLIDE TIGHT LINE SAFETY

A new mechanical tight line safety for tape operated Linotypes has been designed to prevent tight lines from being delivered to the first elevator jaws. This safety can be adjusted so that a tight line will not pass between the long and short delivery slide fingers which will automatically stop the operating unit.

APPLIED TO NEW MODELS

The delivery slide tight line safety is supplied as a component part of the TTS Safeties Attachment which is optional equipment on new Linotypes. The new tight line safety eliminates the need for the assembling elevator latch solenoid which will no longer be supplied as part of the TTS Safeties.

OUTSTANDING LINOTYPES

Can be applied to outstanding Linotypes with Self-Locking Delivery Slide (serial No. 55835 and up) as part of the TTS Safeties Attachment, or as a separate unit (part 38-0340-01).

NO. 343