

G. H. BURKE.
 METAL SAW.
 APPLICATION FILED MAY 21, 1908.

993,150.

Patented May 23, 1911.

6 SHEETS—SHEET 1.

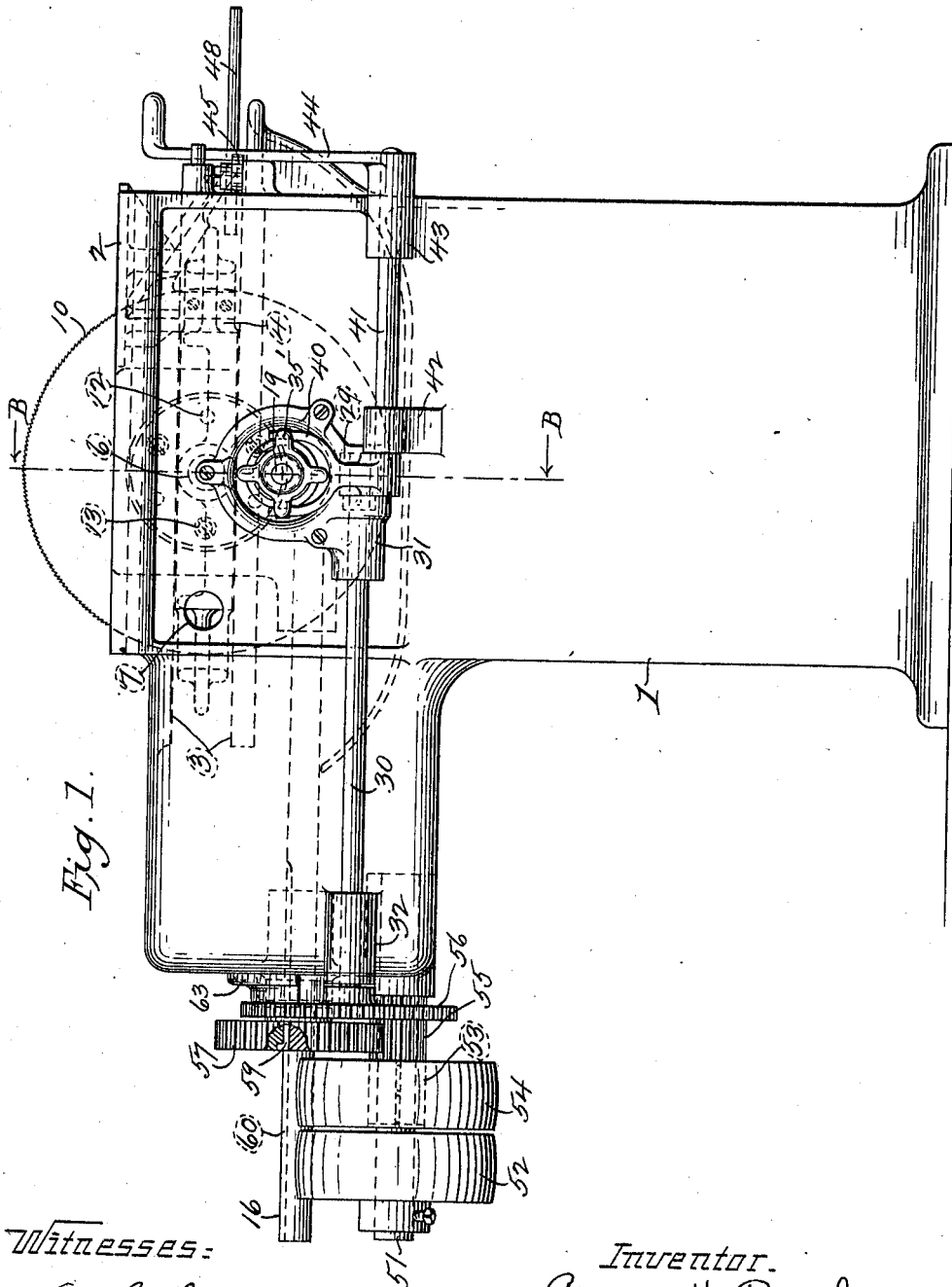

Fig. 1.

Witnesses:

A. L. Lord,
 Ray Miss

Inventor.

George H. Burke
 by
 Brockitt & Lewis,
 Attorneys.

G. H. BURKE.
 METAL SAW.
 APPLICATION FILED MAY 21, 1908.

993,150.

Patented May 23, 1911.

6 SHEETS—SHEET 2.

Fig. 2.

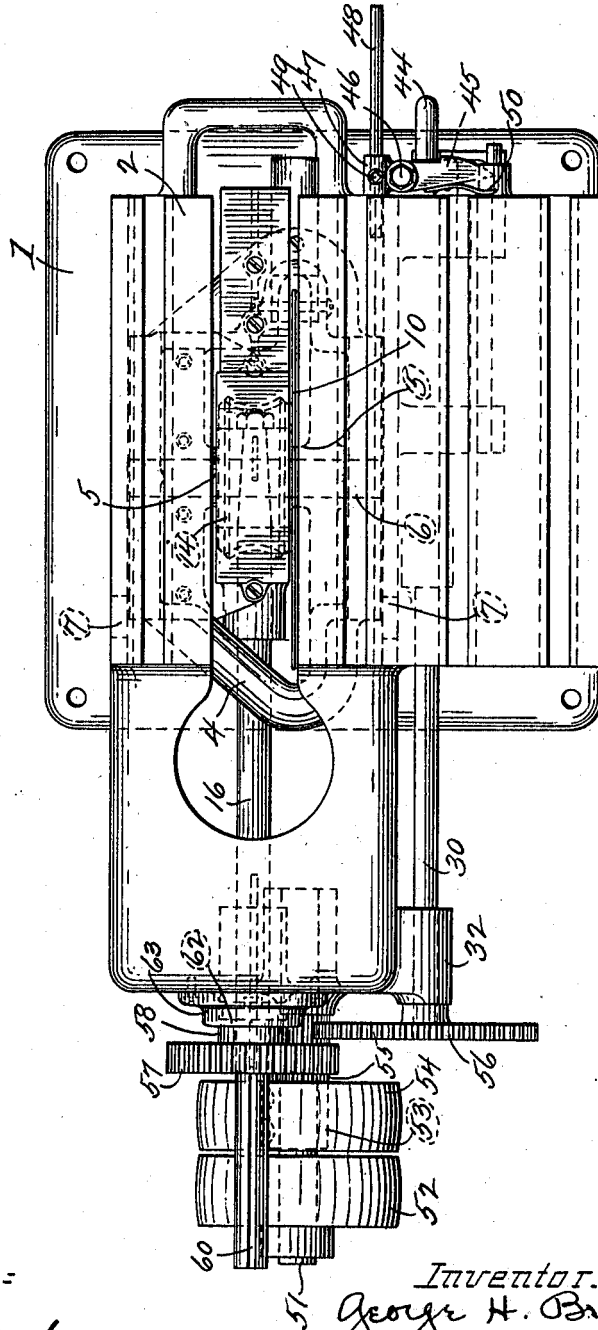

Witnesses:

A. L. Lord
 Roy W. Hill

Inventor.

George H. Burke

By
 Brockitt & Lewis,
 Attorneys.

G. H. BURKE.
METAL SAW.

APPLICATION FILED MAY 21, 1908.

993,150.

Patented May 23, 1911.

6 SHEETS-SHEET 3.

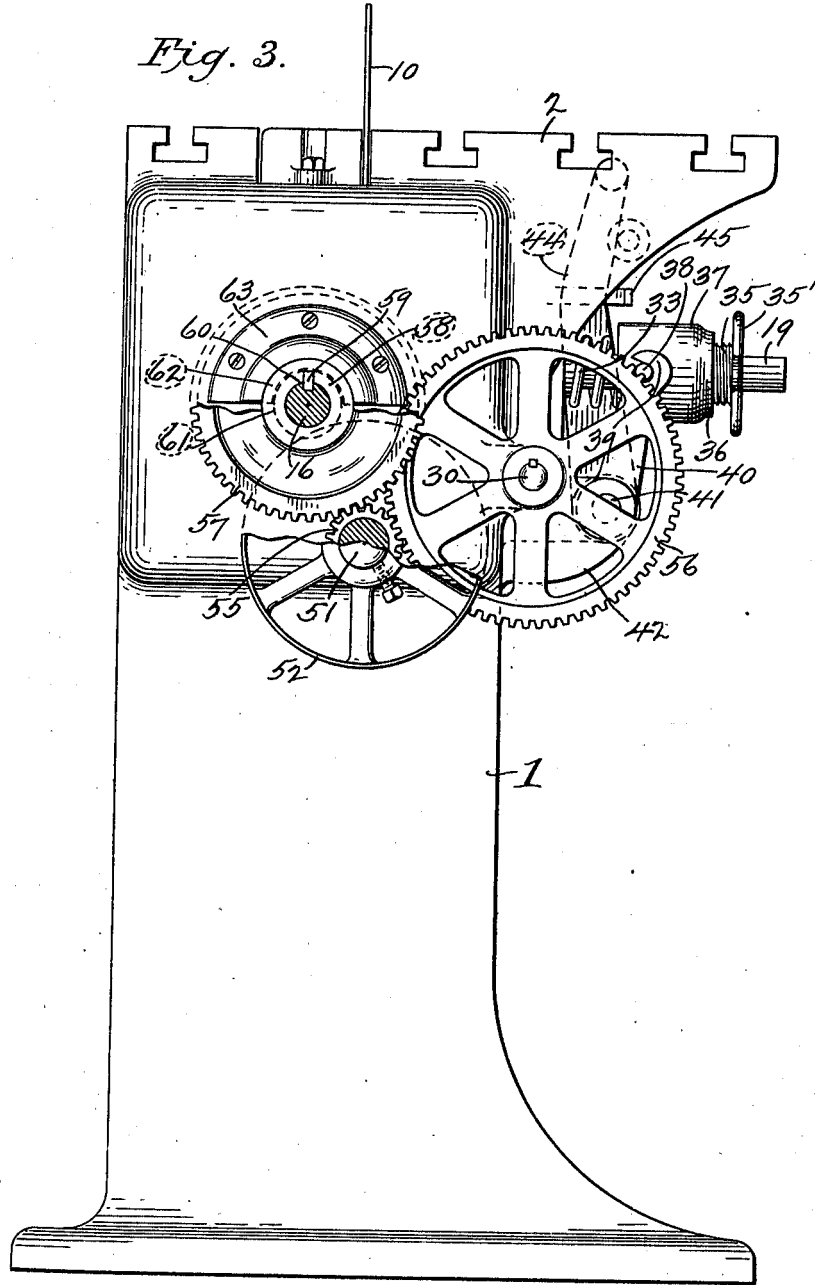

Witnesses:

A. L. Lord.
Rai Miss

Inventor.

George H. Burke
by
Brockitt & Skuis
Attorneys

G. H. BURKE.
 METAL SAW.
 APPLICATION FILED MAY 21, 1908.

993,150.

Patented May 23, 1911.

6 SHEETS—SHEET 4.

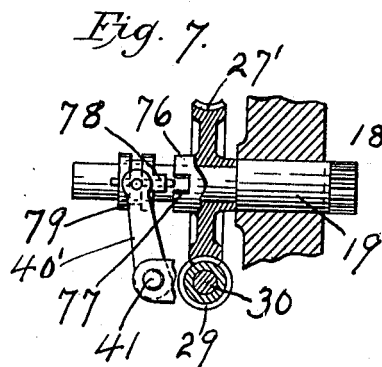
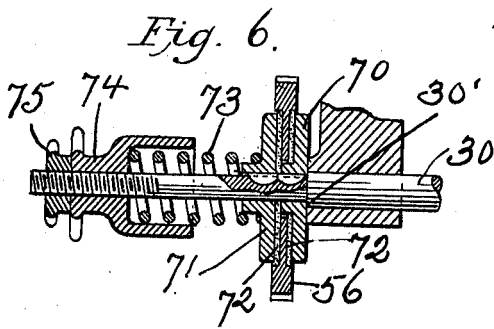
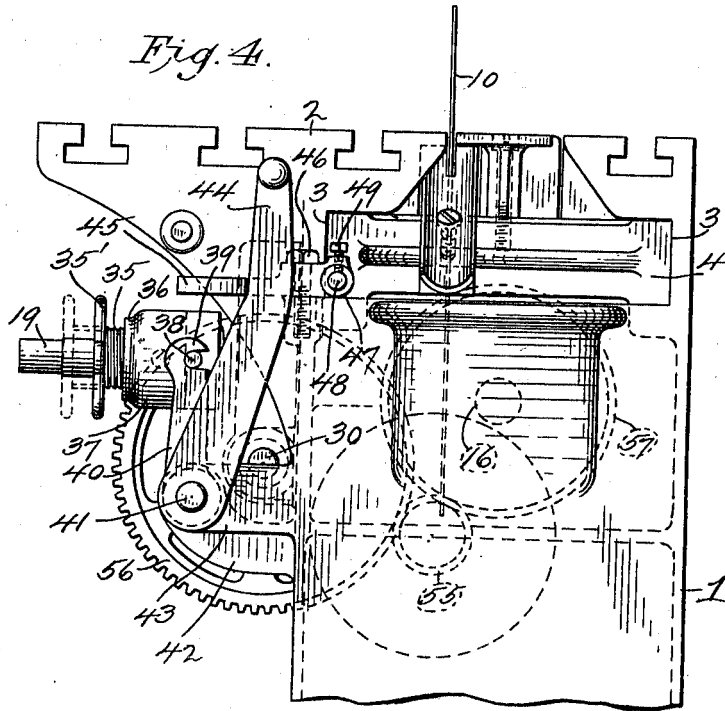

Witnesses:

A. L. Lord.
 Ray Weiss

Inventor.

George H. Burke
 by
 Brackett & Lewis.
 Attorneys.

G. H. BURKE.
METAL SAW.
APPLICATION FILED MAY 21, 1908.

993,150.

Patented May 23, 1911.

6 SHEETS—SHEET 5.

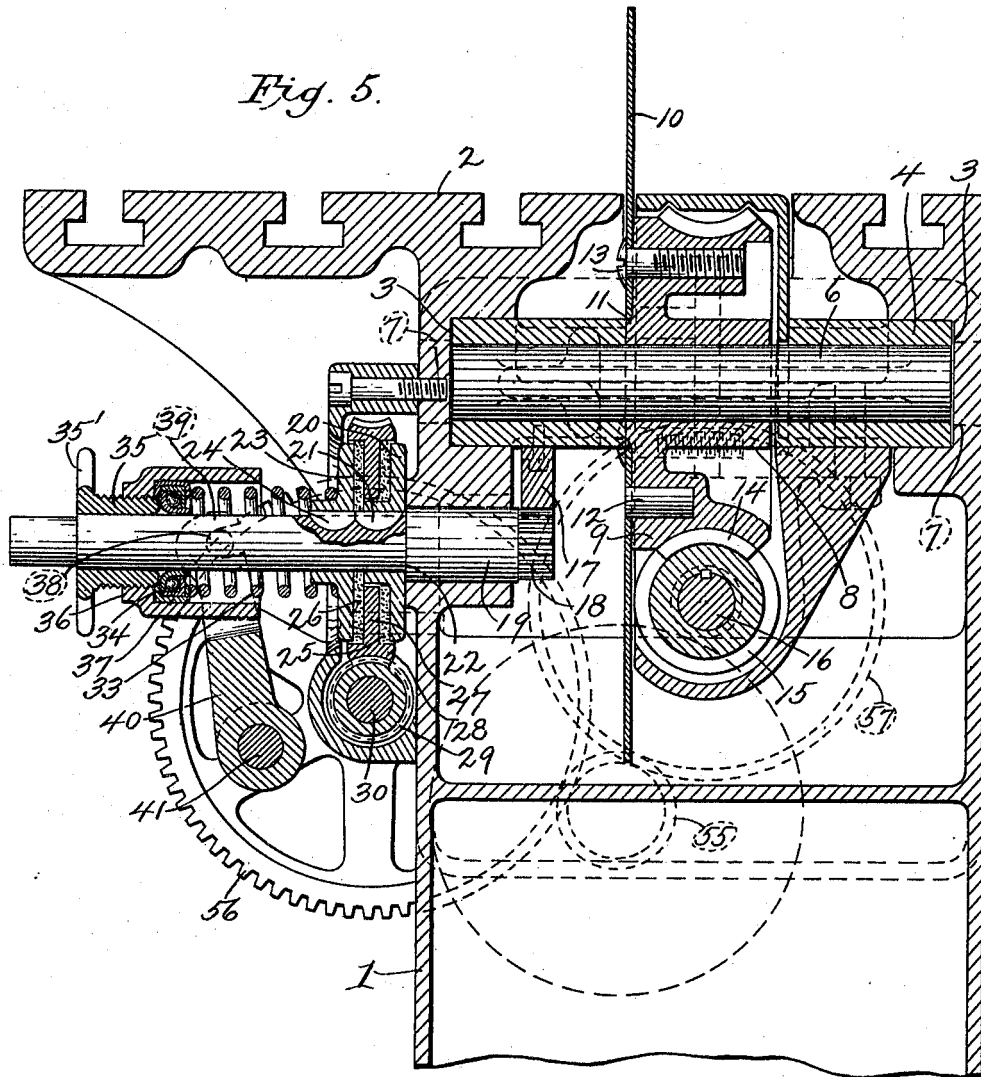

Witnesses:

A. L. Lord.
Ray Weiss

Inventor.
George H. Burke
by
Brockett & Lewis.

Attorneys.

UNITED STATES PATENT OFFICE.

GEORGE H. BURKE, OF EUCLID, OHIO, ASSIGNOR TO BURKE MACHINERY COMPANY,
OF CLEVELAND, OHIO, A CORPORATION OF OHIO.

METAL-SAW.

993,150.

Specification of Letters Patent. Patented May 23, 1911.

Application filed May 21, 1908. Serial No. 434,074.

To all whom it may concern:

Be it known that I, GEORGE H. BURKE, a citizen of the United States, residing at Euclid, in the county of Cuyahoga and State of Ohio, have invented certain new and useful Improvements in Metal-Saws, of which the following is a specification.

This invention relates to improvements in metal saws and particularly to those wherein a circular saw is suitably mounted and provided with driving mechanism.

More specifically the invention relates to the construction employed for supporting the saw itself and driving the same whereby it is susceptible of receiving more power for the driving operation and is less apt to be sprung out of alinement.

The invention further relates to other features hereinafter set forth in the following description, drawings and claims.

Referring to the drawings Figure 1 is a side elevation of my device: Fig. 2 is a top plan view: Fig. 3 is an end elevation looking toward the right as shown in Fig. 1: Fig. 4 is an end elevation looking to the left of Fig. 1; Fig. 5 is a section upon the line B B looking toward the left in Fig. 1; Fig. 6 shows a modified arrangement of the friction clutch mechanism upon the high speed shaft and Fig. 7 shows a positive clutch or dental clutch on the slow speed shaft.

Any preferred form and construction of parts may be employed in the carrying out of my invention but I have shown one form in the drawings which meets the requirements with great efficiency.

Frame.—In such embodiment 1 represents a frame or base, which is provided at its top with a suitable table 2 adapted to receive the work and with suitable guide-ways 3, shown in Fig. 5, for receiving a reciprocating carriage 4 shown in dotted and full lines in Fig. 2, in full lines in Fig. 4 and partially in section in Fig. 5.

Carriage.—The carriage, as shown best in Fig. 2, is provided with a pair of transverse bosses 5 which support a short shaft 6 driven into suitable openings in these bosses through an opening 7 in the frame of the machine. A similar opening 7, shown in dotted lines in Fig. 2, is provided on the back of the frame work of the machine to furnish access to the other end of this short shaft 6, whereby it may be driven in and out of the bosses. Rotatably mounted upon this shaft 6 is a

hub 8 provided with an enlarged flange portion 9 which receives against its face the saw 10, and is provided with an annular shoulder 11, which fits in an opening at the center of the saw in a well known manner. The flange 9 is further provided with suitable pins 12, preferably three in number, which fit suitable openings in the saw and are adapted for the purpose of receiving a portion of the strain which might otherwise come upon the retaining screws 13 which are also secured in the flange 9 through openings in the saw. The flange 9 still further carries a worm gear 14 which engages with a driving worm 15 keyed to a shaft 16 mounted in suitable bearings in the frame work and later to be more fully described. The carriage is further provided with a rack 17 which meshes with a spur pinion 18 mounted upon a shaft 19 having its bearing in the side of the frame work. This rack and pinion just described serve as means for moving or shifting the carriage forward in its guide-ways and to or from the work while the worm gearing in connection with the saw is for the purpose of driving that part of the mechanism.

Carriage feed.—This mechanism consists of a friction disk 20 rigidly connected by means of a key 21 with the shaft 19 as shown in Fig. 5 and adapted to take against a shoulder 22 on said shaft, a friction disk 23 loosely keyed by means of a key 24 to the shaft 19, and between these two friction disks fiber washers 25 and 26 which take on either side of the web 27 of a worm wheel 28 which meshes with a worm 29 keyed to a shaft 30 mounted in a bearing 31 near said worm and a bearing 32 near the left hand end of the machine as shown in Fig. 1. This shaft 30 receives its power from the driving mechanism to be described, and is arranged to drive the worm wheel, which may or may not drive the shaft 19, through its frictional connection therewith, according to the amount of tension which is brought to bear upon the friction disk 23. This tension is created by means of a spring 33 engaging said friction disk and bearing against one member of a ball bearing construction 34 which takes against the end of a sleeve 35 loosely mounted upon the shaft 19 and threaded into a hub 36 of a casing member 37 which is provided as shown in Figs. 1, 3, 4 and 5 with diametrically opposed pins 38

projecting from the periphery thereof and adapted to be engaged by a hook end 39 of a rocker arm 40 carried by a rock shaft 41 supported by bearings 42 and 43 and having
 5 upon the other end thereof a shifting lever 44 which is adapted to serve as means for shifting the casing member 37. A hand wheel 35' is provided on the outer end of the sleeve 35 for adjusting the same in and
 10 out of the casing member 37, whereby the tension to be exerted by the spring 33, when the hand lever 44 is shifted may be regulated as desired.

A suitable latch 45 shown in Figs. 1 and 2
 15 and 4 is pivoted at 46 to the frame of the machine and carries a socket 47 which receives a stop rod 48 which may be held in any suitable or desired position in the socket 17 by means of a set screw 49. A spring 50
 20 carried by this latch 45 and bearing against the side of the frame normally holds the former out in the path of the hand lever 44. The stop rod 48 is arranged so that it is always in the path of the carriage and when
 25 adjusted may be engaged by the latter at any desired point and when engaged will shift the latch and release the hand lever, which operation permits the spring 33 to shift the casing member 37 into its outer-
 30 most position, and when in this position the tension exerted by the spring 33 upon the friction disk 23 is insufficient to bring about the driving of the shaft 19 by the worm wheel 28 hence there is no feeding of the
 35 carriage.

Driving mechanism.—The driving mechanism is clearly shown in Figs. 1, 2 and 3 and it consists of a short counter shaft 51 secured in the frame work of the machine
 40 and carrying a loose pulley 52 and a sleeve 53, shown in dotted lines in Fig. 2, having a pulley 54 keyed to the same and a long spur gear 55 which is adapted to mesh with a gear 56 keyed to the shaft 30 and with a
 45 gear 57 carried by a sleeve 58 provided with a spline 59, shown in Figs. 1 and 3, and engaging in a key-way 60 in the shaft 16 whereby the shaft is free to move longitudinally within said sleeve and adapted to be driven thereby. The sleeve 58 is also provided with a recess 61 which is arranged to be engaged by a flange 62 carried by a member 63 secured to the frame work. The construction of this portion of the driving
 50 mechanism is such that the gear is held from longitudinal movement with respect to the shaft 16 but is permitted to rotate and drive the same.

Operation.—A suitable power belt, not shown, on being shifted from the loose pulley 52 to the pulley 54 transmits power to the pinion 55 and the shafts 16 and 30 are driven by the gear 57 and 56 respectively. The driving of the shaft 16, through the
 60 worm 15 and the worm gear 14, brings about

the driving of the saw 10. The hand lever 44 is then shifted into engagement with the latch 45 bringing about the movement of the casing member 37 toward the friction disk 23 and causing the spring 33 to exert
 70 its tension against the former and bringing about the driving of the shaft 19 by the worm gear 28, which operation, through the pinion 18 and rack 17, feeds the carriage 4
 75 forward. The carriage will continue to be fed forward until it engages the end of the rod 48 when the latch 45 will be shifted causing the release of the handle 44, the shifting of the casing 37 and the disengagement of the members of the friction clutch.
 80 As soon as this takes place the carriage stops. It is quite obvious that the thrust of the spring 33 will be taken up by the ball bearing construction 34 and there will be no undue friction brought to bear between it
 85 and the casing member. It is further quite obvious that the tension of this spring may be varied by operating the hand wheel 35'.

In the modification shown in Figs. 6 and 7 the friction drive for the carriage feed
 90 may be arranged upon the high speed member, which in this instance is the shaft 30, in place of being arranged upon the worm wheel 27. In this arrangement the shaft 30 is provided with a disk 70 keyed to said
 95 shaft and arranged to take against a shoulder 30' on said shaft. Another friction disk 71 is slidably mounted upon the shaft 30 but is keyed thereto in a manner such that it may slide thereon. Between these disks
 100 are friction washers 72 arranged on either side of the gear wheel 56 and the construction at this point is such that upon a tension being brought to bear upon the disk 71 the gear wheel 56 will drive the shaft 30, but
 105 upon an undue strain being brought to bear upon the shaft 30 this friction device will permit the gear 56 to turn without rotating the shaft 30. This prevents the breaking of the parts of the carriage feed.
 110

The mechanism for creating tension upon the disk 71 consists of a spring 73 about the shaft 30 and adapted to be adjusted to any desired tension by means of a follower nut 74 engaging the threaded end of the shaft
 115 30 and held in any adjusted position by a setting nut 75. When the arrangement of friction drive, just described, is employed the shaft 30 is geared to the shaft 19 by means of the worm 29 and the worm wheel
 120 27', but the latter is provided with a hub 76 loose upon the shaft and having in one face thereof recesses 77 adapted to receive lug 78 carried by a clutch member 79 loosely splined upon the shaft 19. By this arrangement it will be seen that the driving mechanism for the carriage may be thrown in and out of operation by shifting the clutch member 79 through the operation of the
 125 lever 40'.
 130

Having described my invention, I claim:

1. In a metal saw, in combination, a frame, a movable carriage mounted therein, an arbor mounted in said carriage and having two supports spaced apart, a saw carrying member rotatably mounted upon said arbor and between said supports, means for securing the saw to said member, means for driving said member and means for feeding said carriage forward. 25
2. In a metal saw, in combination, a frame, a movable carriage, two supports in said carriage, an arbor mounted in said supports, a gear rotatably mounted on said arbor between said supports, a saw fixed to the face of said gear, and means for driving said gear to rotate the saw. 30
3. In a metal saw, in combination, a frame, a carriage movably mounted in said frame and having a pair of spaced supports, an arbor carried by said supports, a hub rotatably mounted upon said arbor, and having a supporting portion of the frame on each side thereof, a flange carried by said hub, a saw secured to said flange, a gear carried by said flange for driving the same, means for driving said gear, and means for feeding the carriage forward. 35
4. In a metal saw, in combination, a frame, a carriage movably mounted therein, and having an opening within the same to receive the saw, an arbor secured in said carriage and supported on each side of said opening, a hub rotatably mounted upon said arbor and between the supports thereof, a saw supporting member carried by said hub, a gear for driving said member, means for driving said gear, and means for feeding said carriage forward. 40

In testimony whereof I affix my signature in presence of two witnesses.

GEORGE H. BURKE.

Witnesses:

A. F. KWIS,
RAE WEISS.

Copies of this patent may be obtained for five cents each, by addressing the "Commissioner of Patents, Washington, D. C."